

115.715 mm³

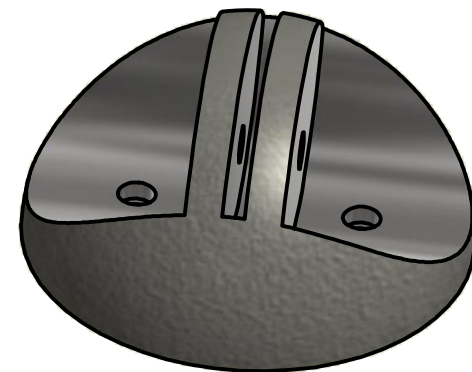

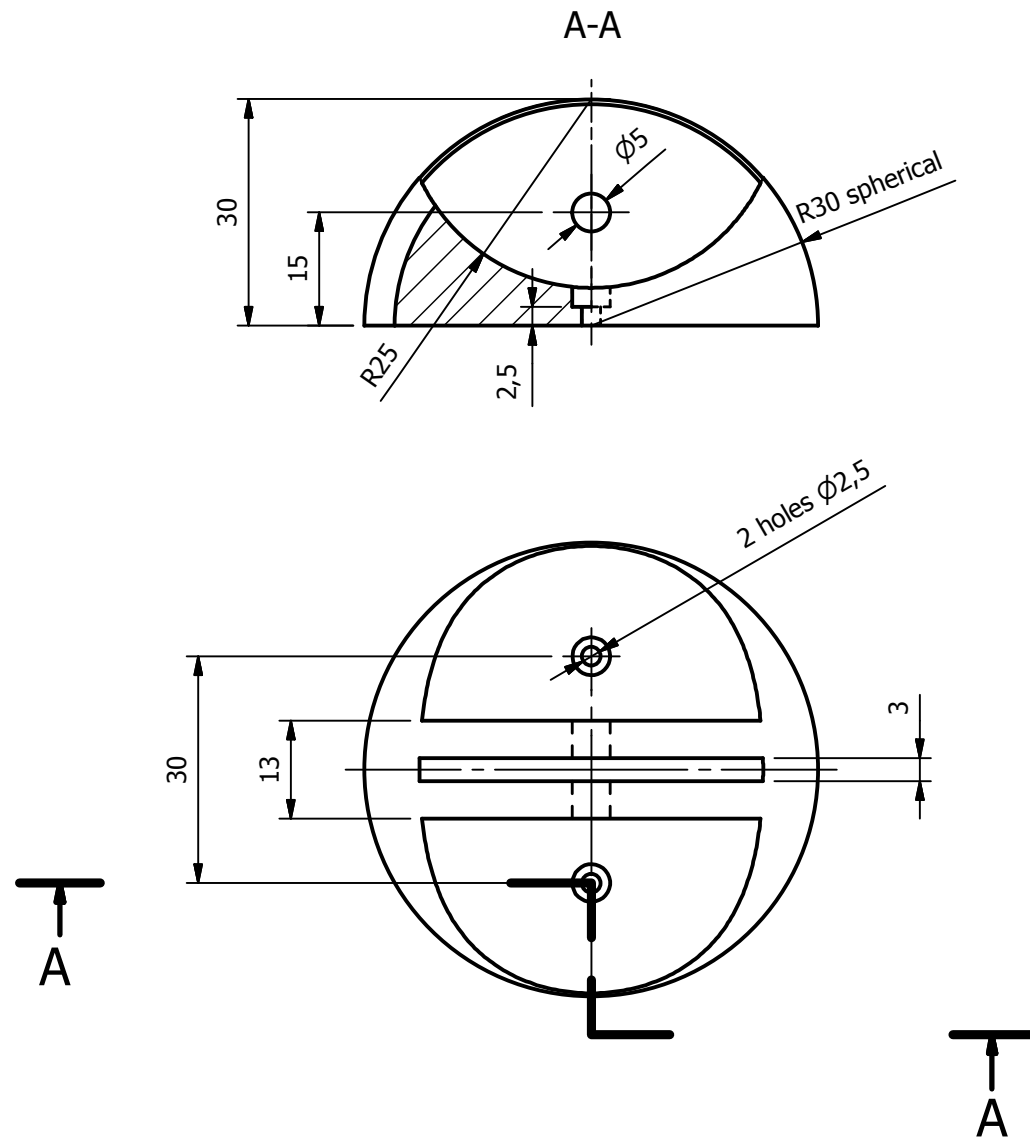

20618.930 mm³

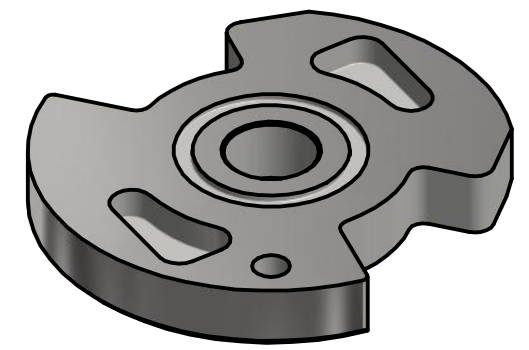
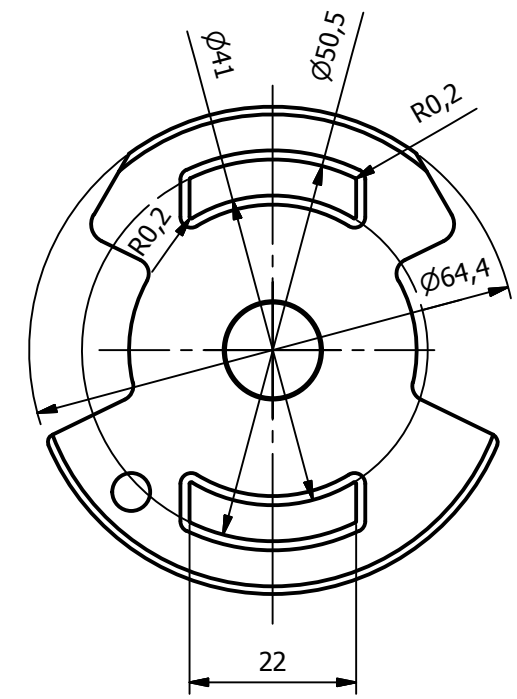
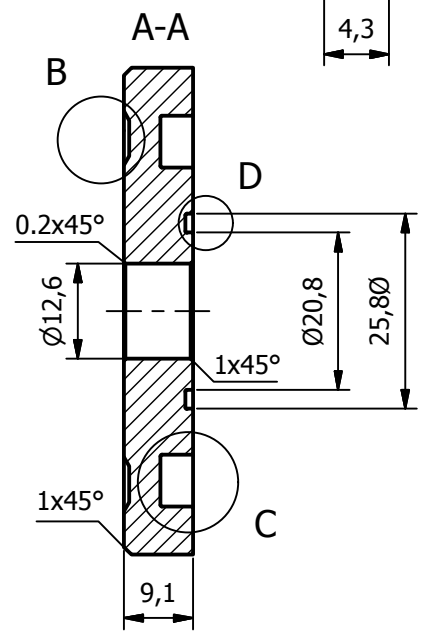
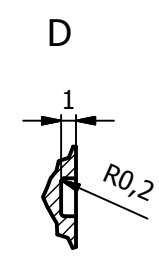
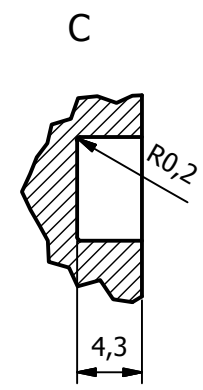
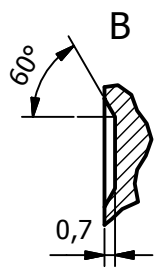
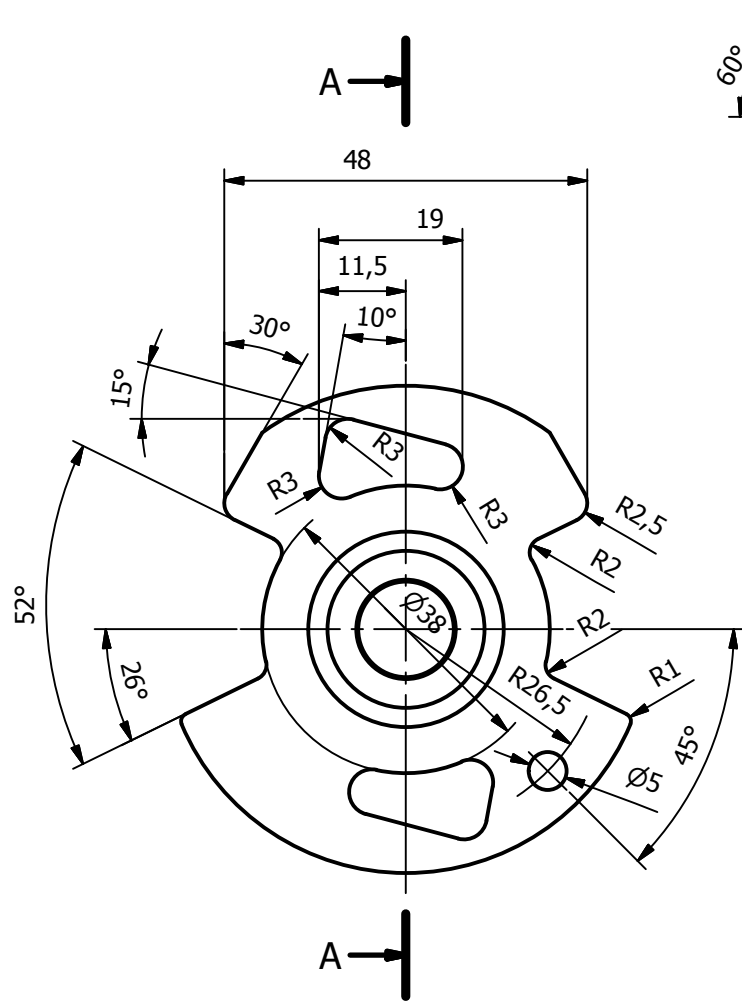
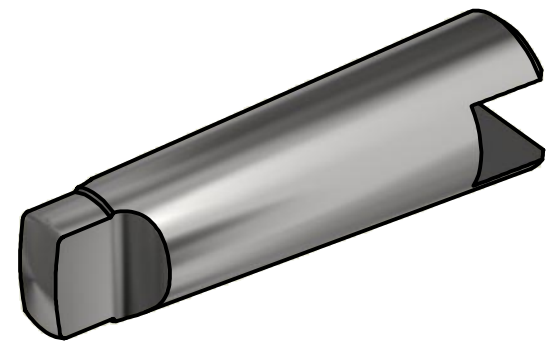
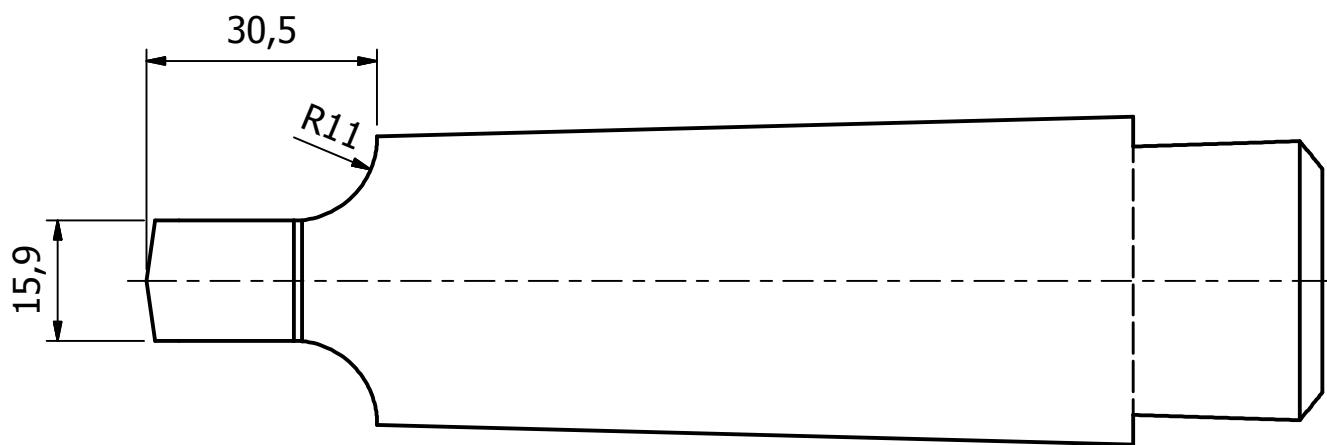
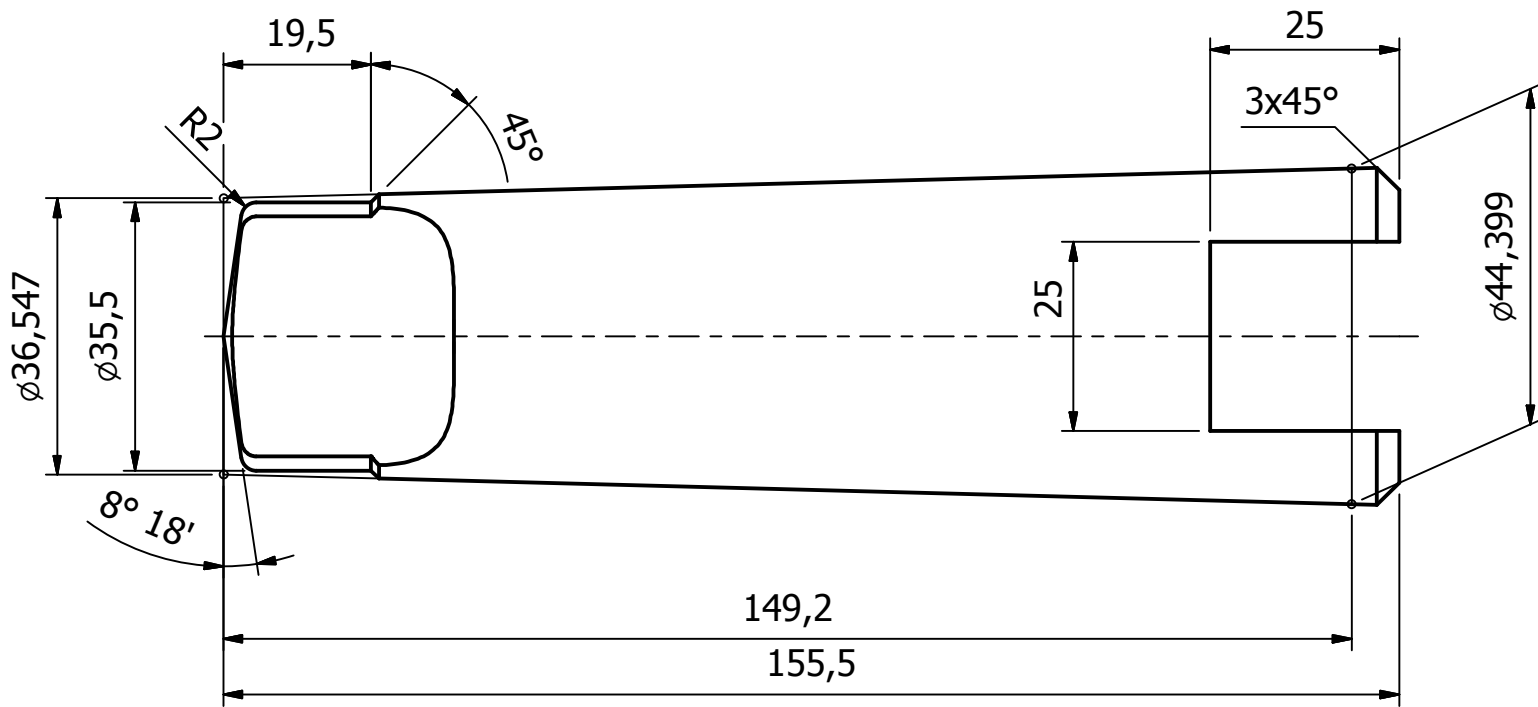

160443.413 mm³

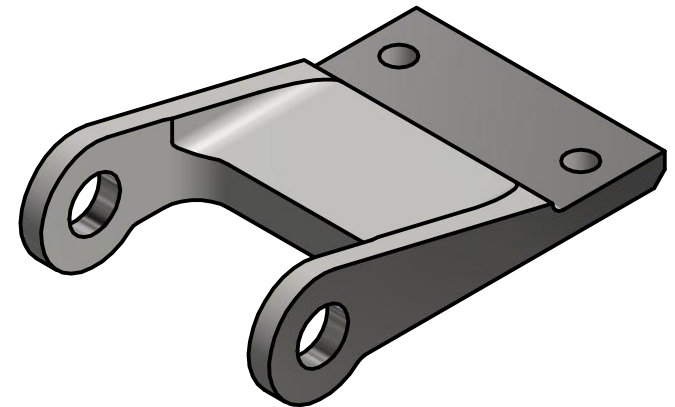
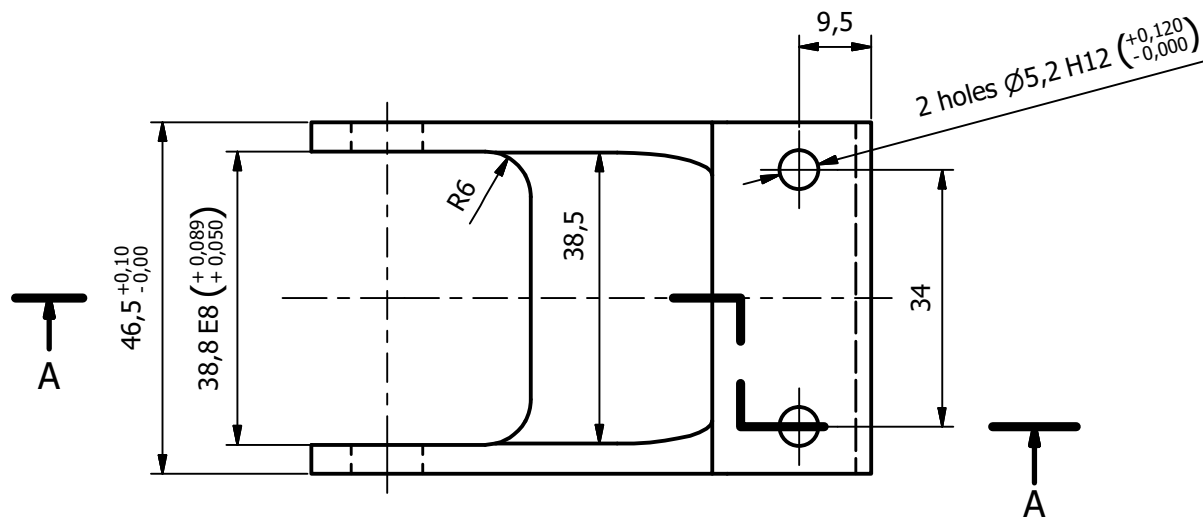
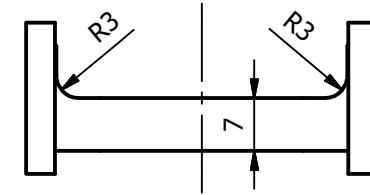
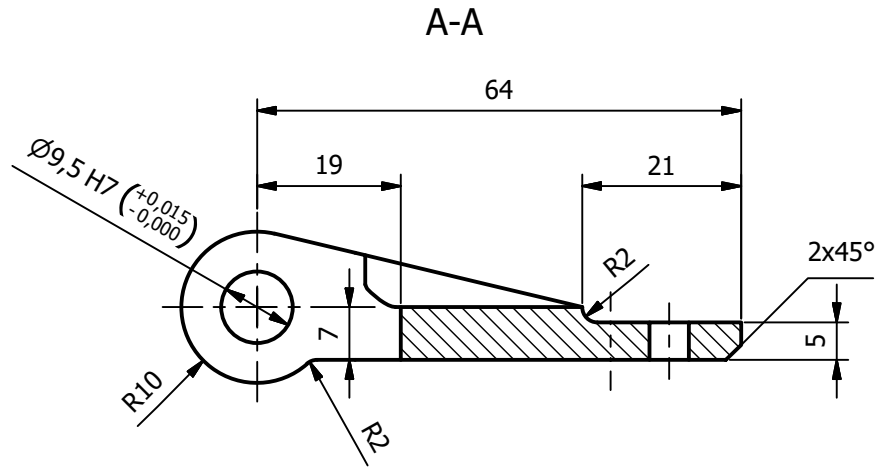

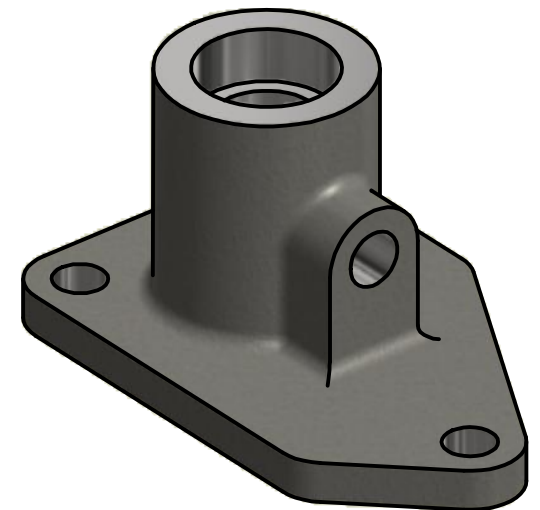
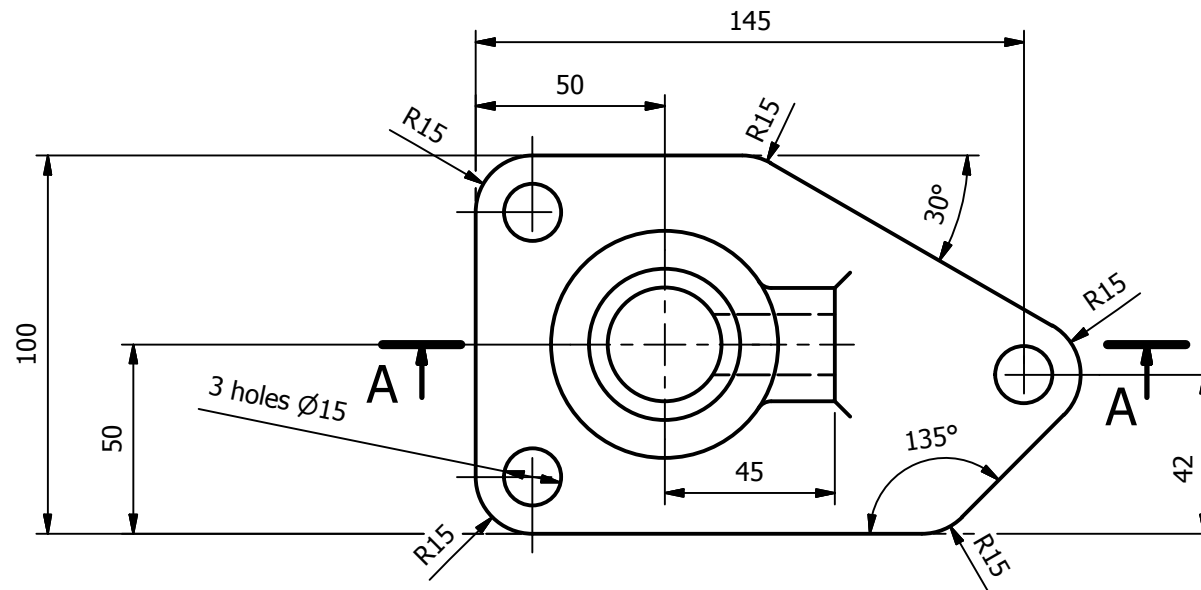
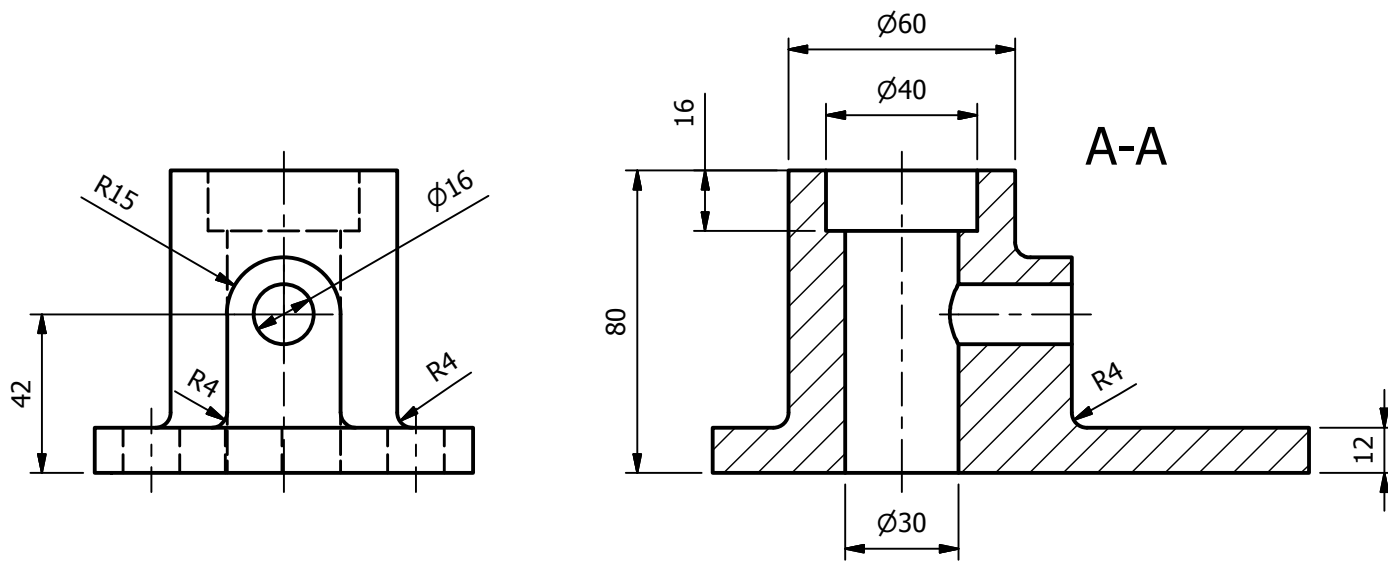

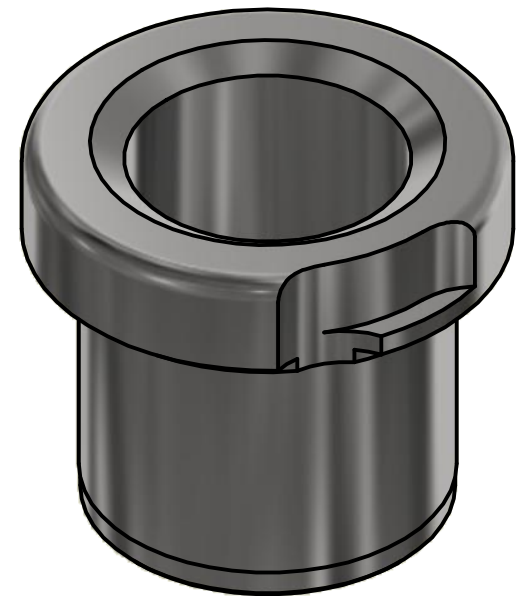
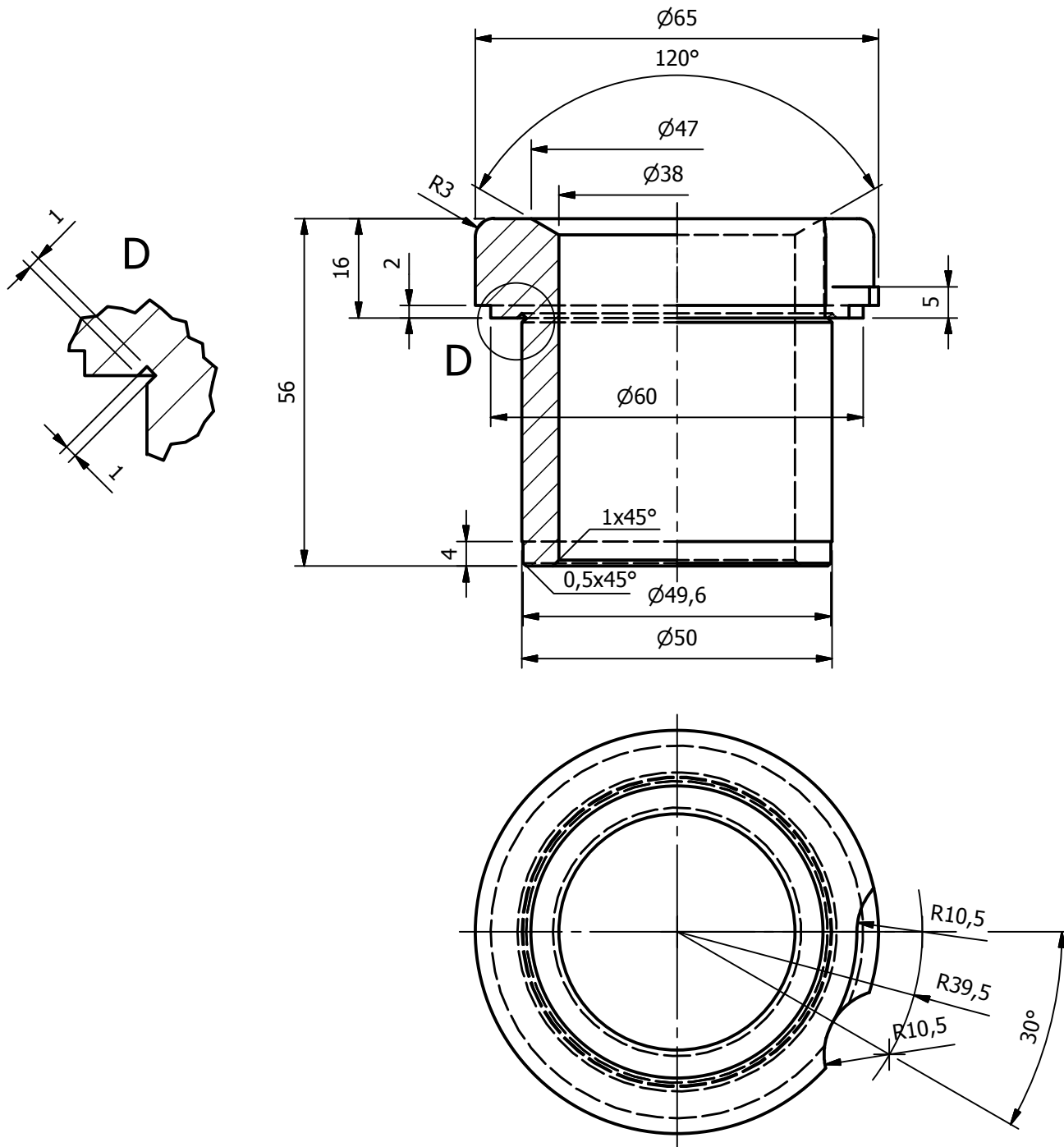

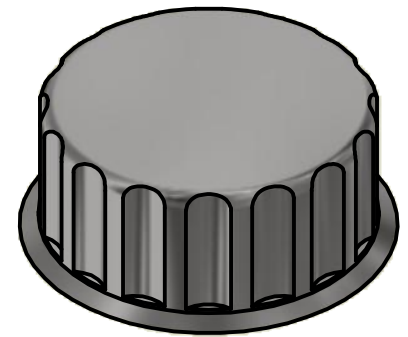
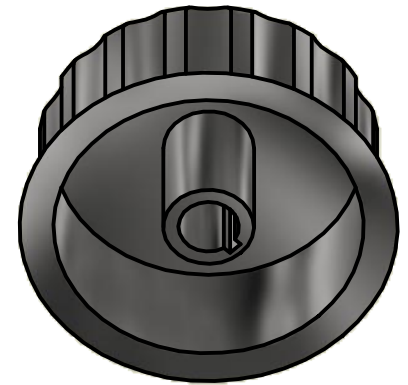
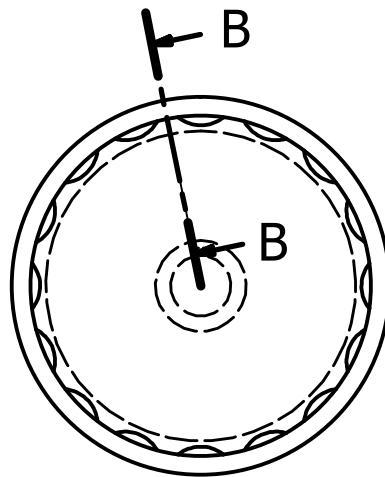
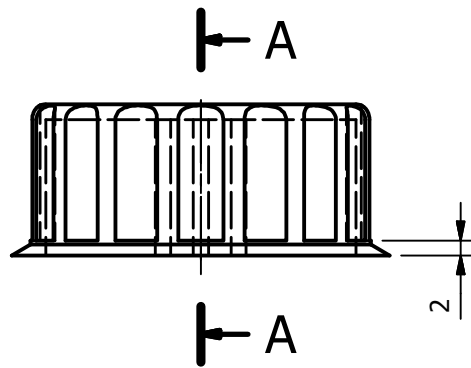
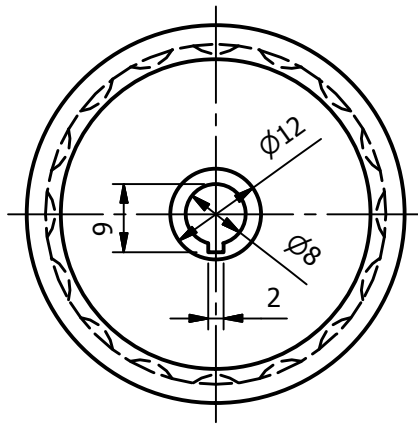
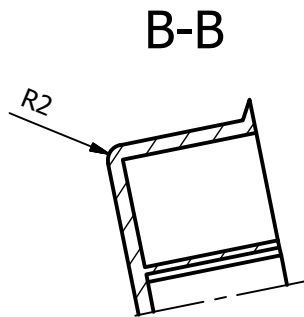
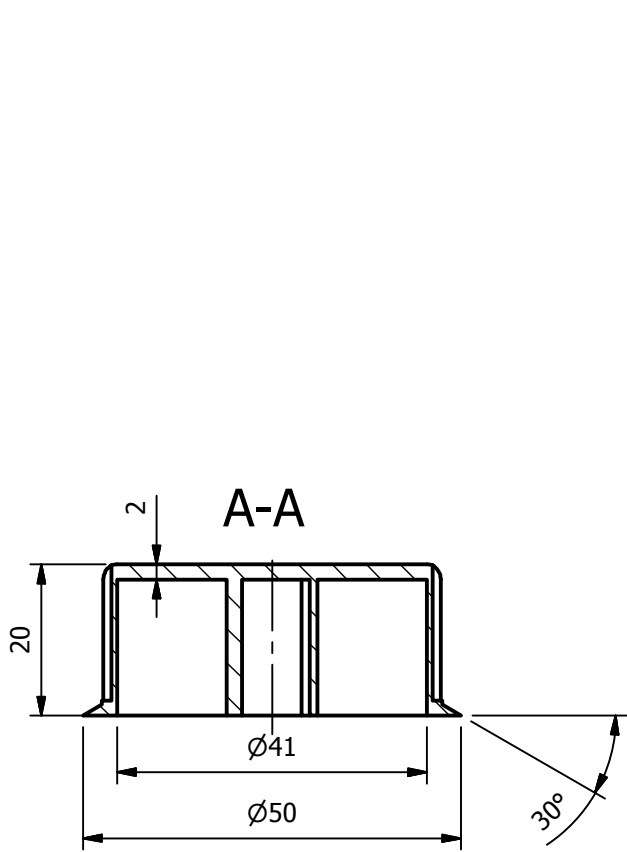

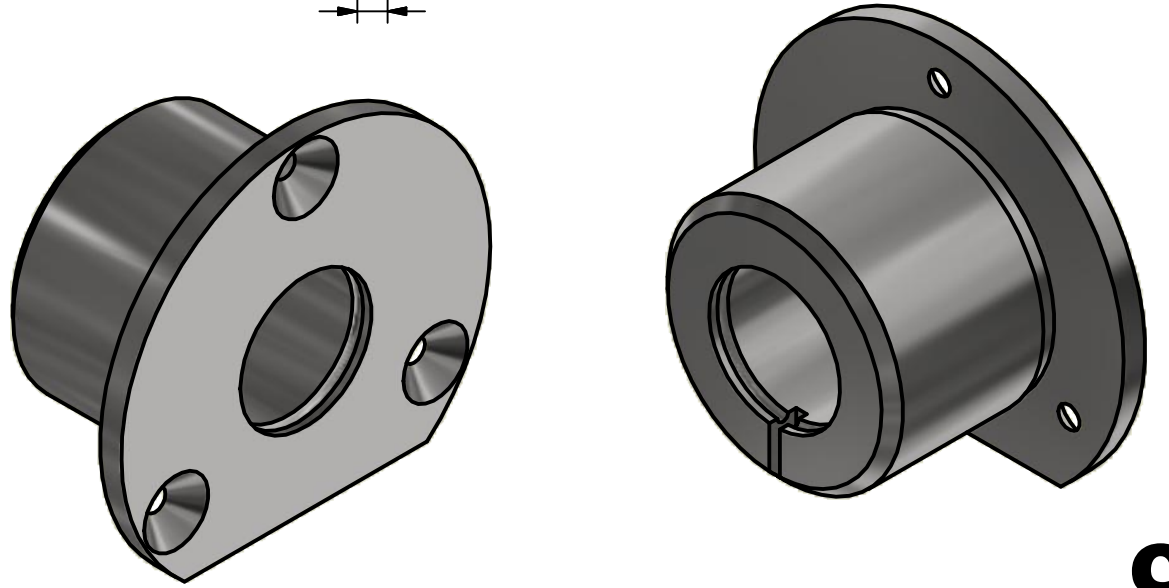
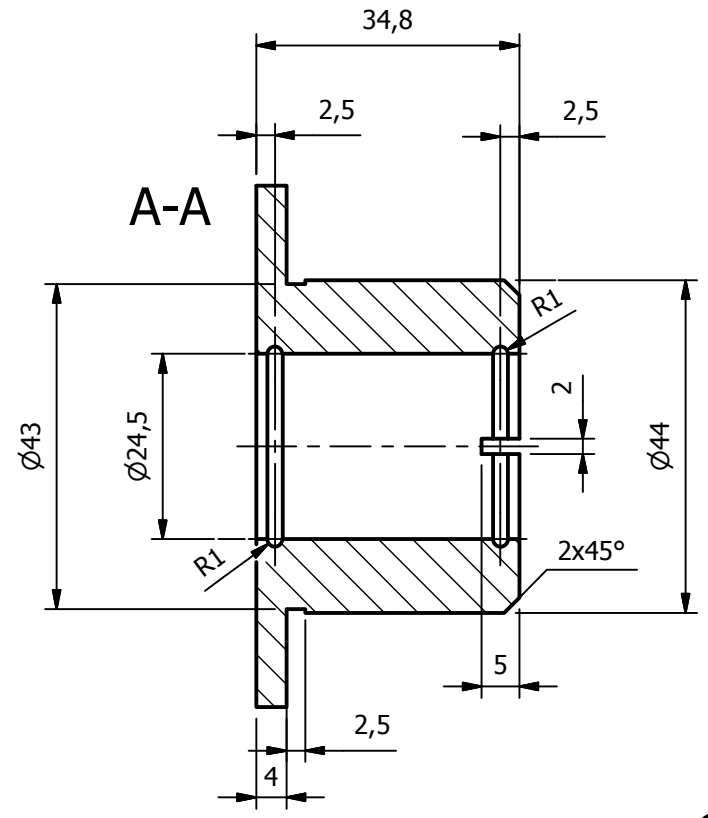
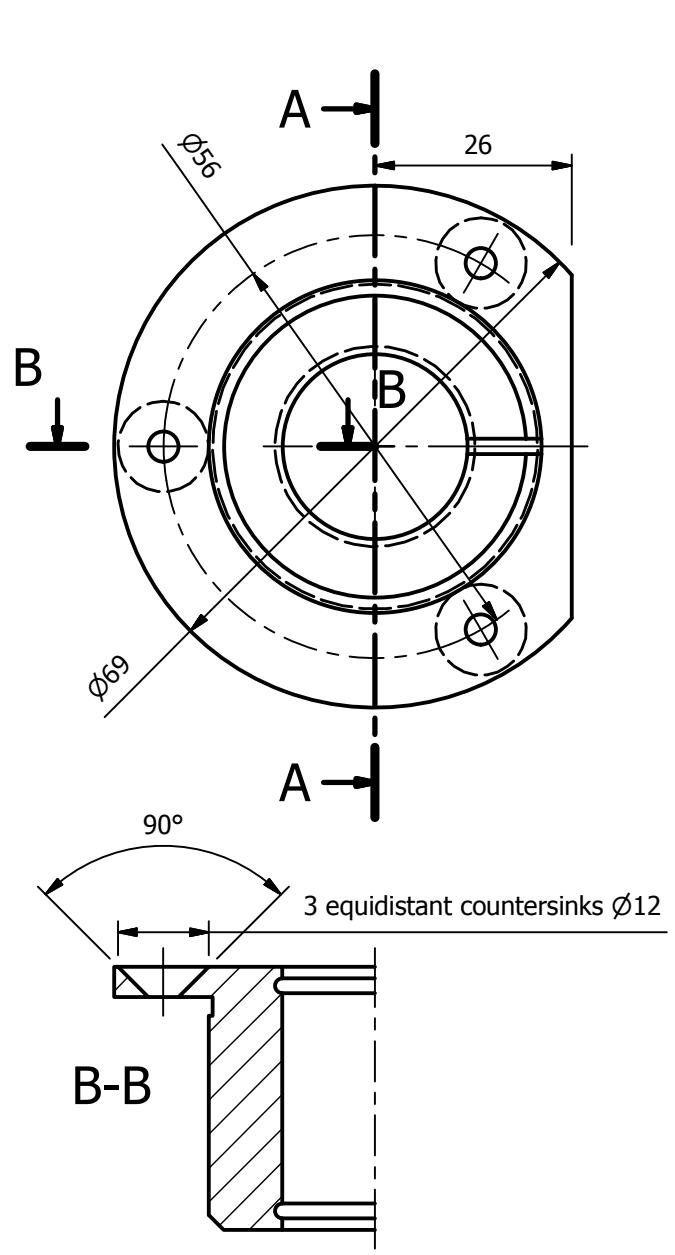

42893.903 mm³

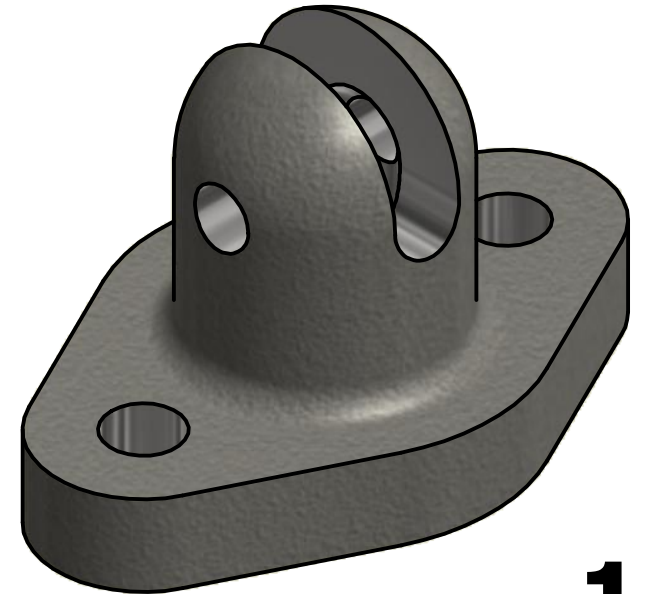
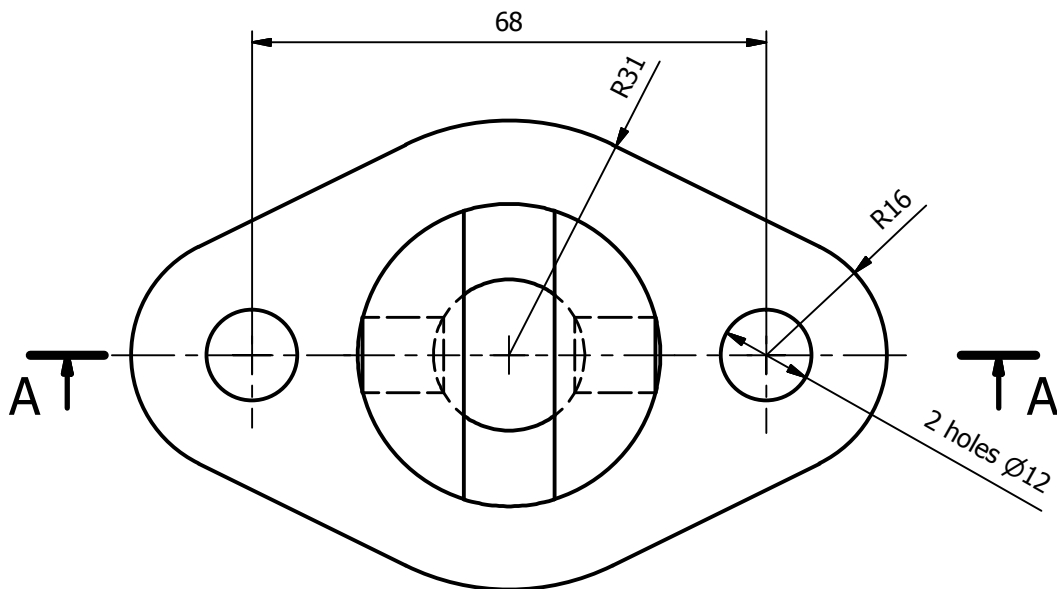
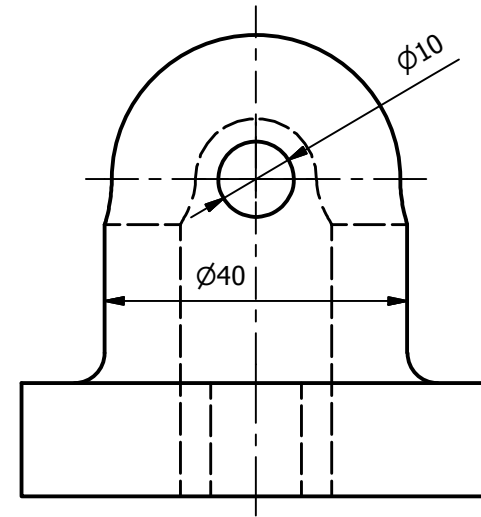
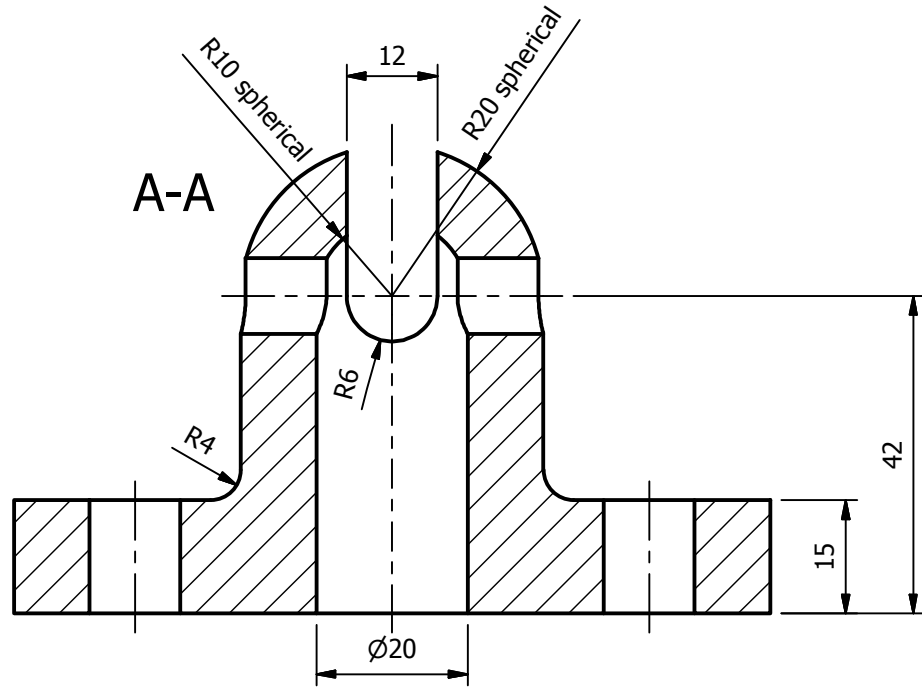

88776.577 mm³

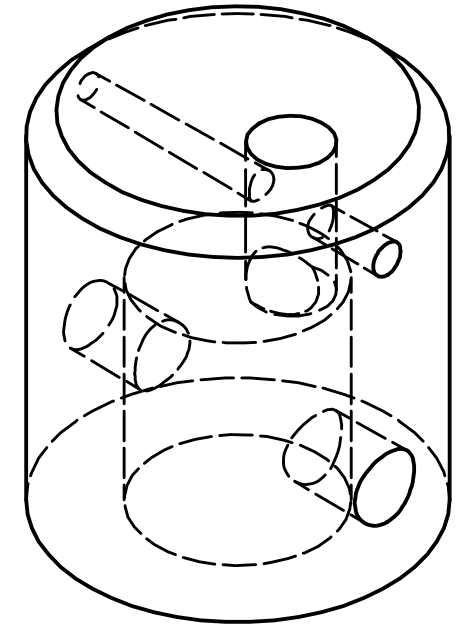
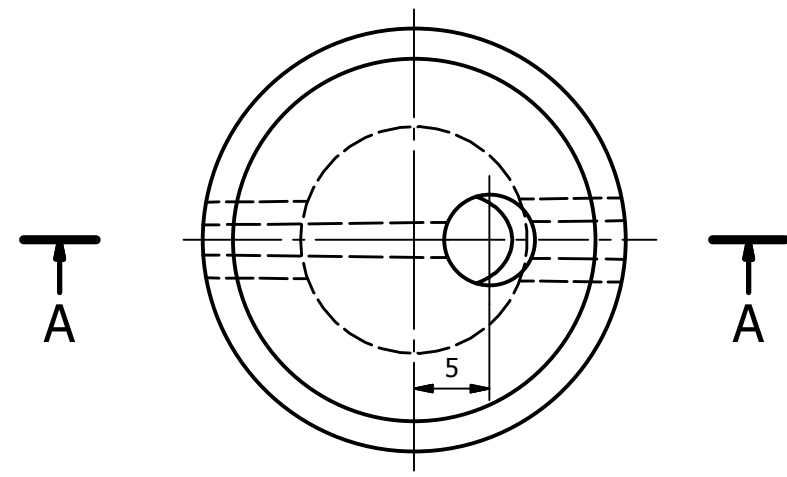
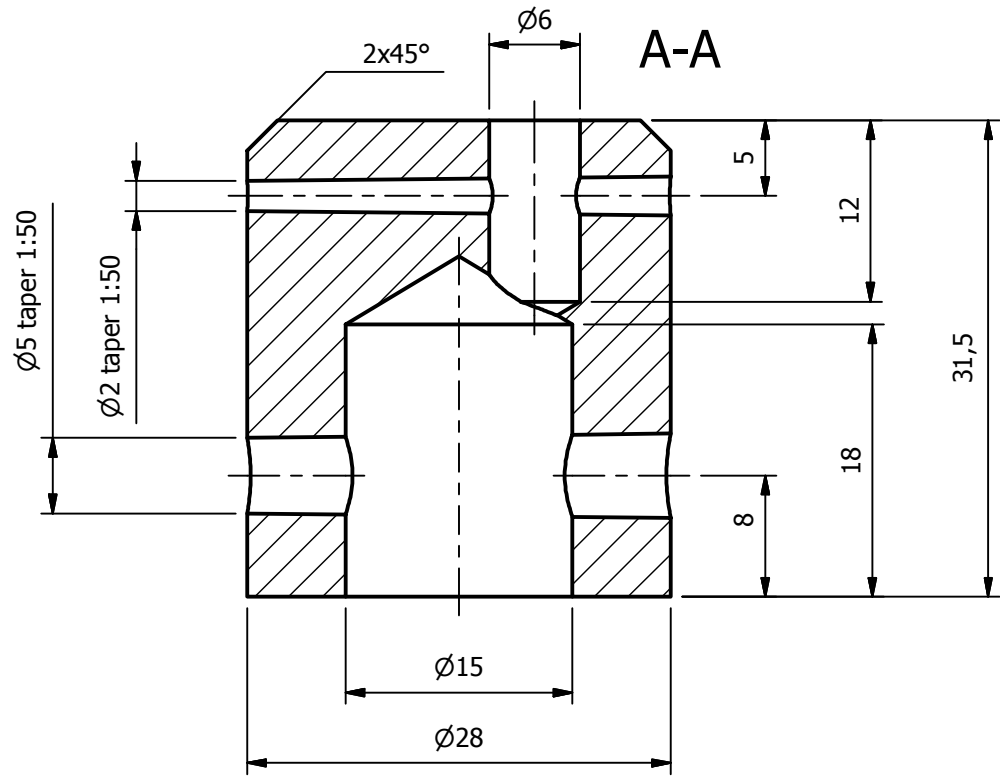

Note: The taper K is the rapport of the diameter difference of two cross sections of a cone and the axial distance between the sections

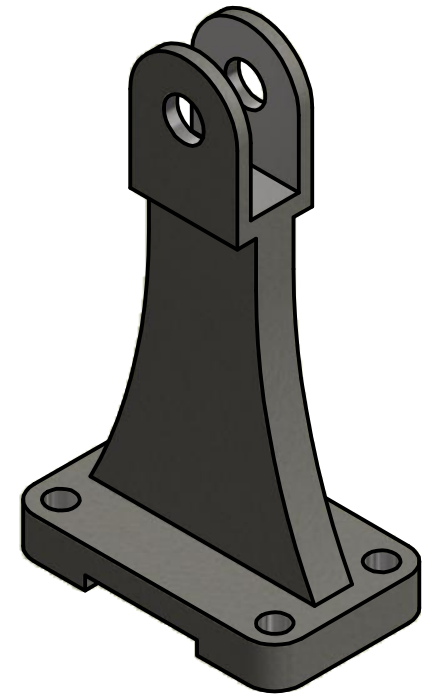
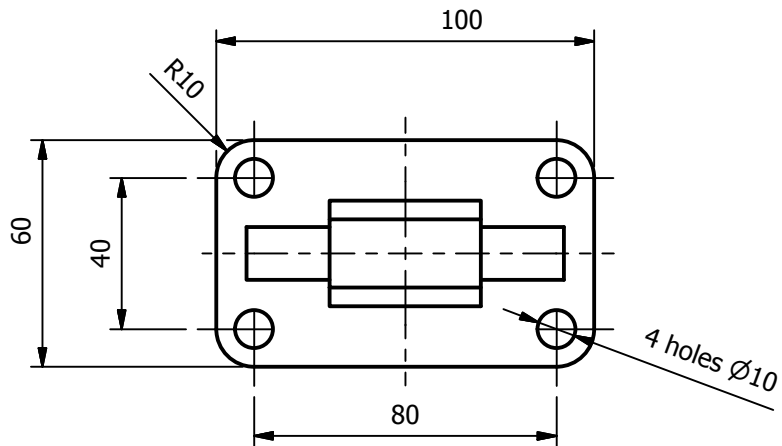
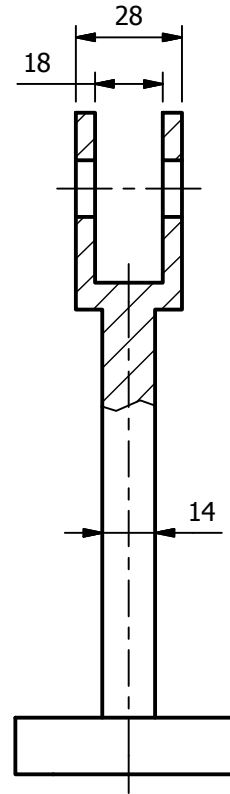
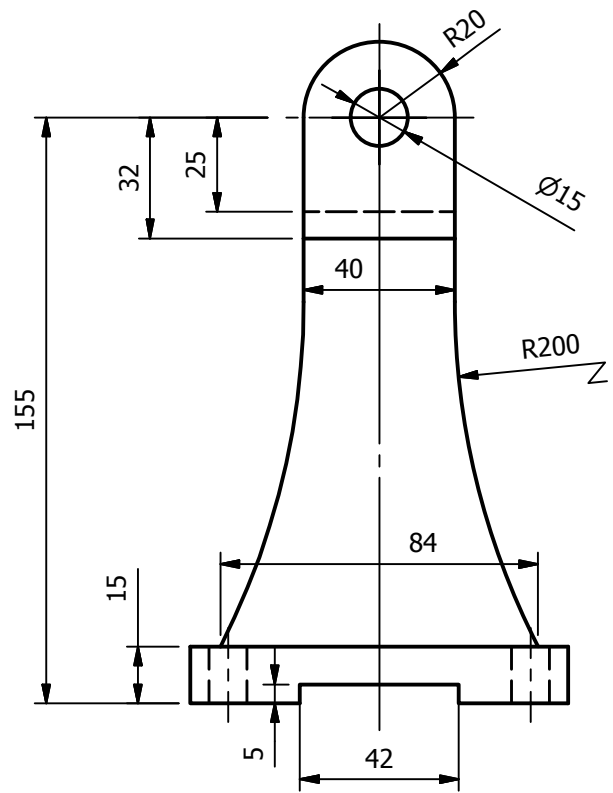

172529.495 mm³

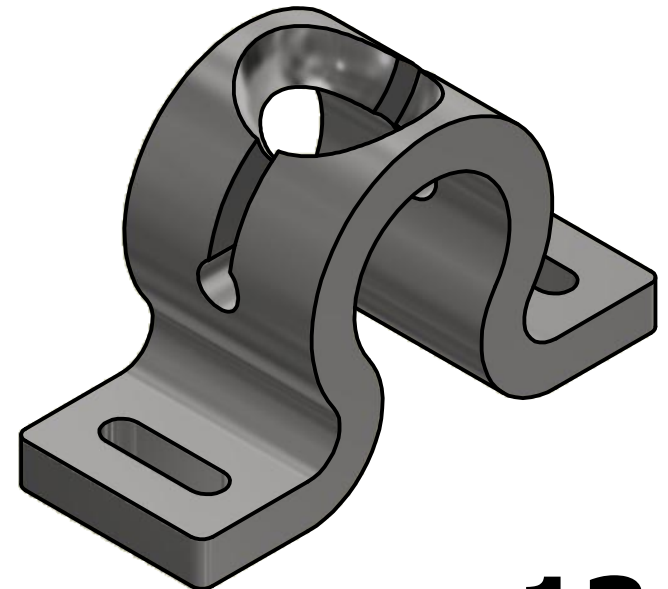
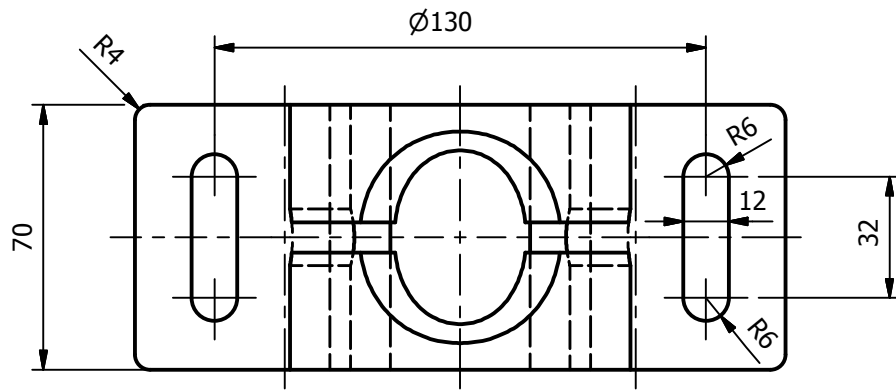
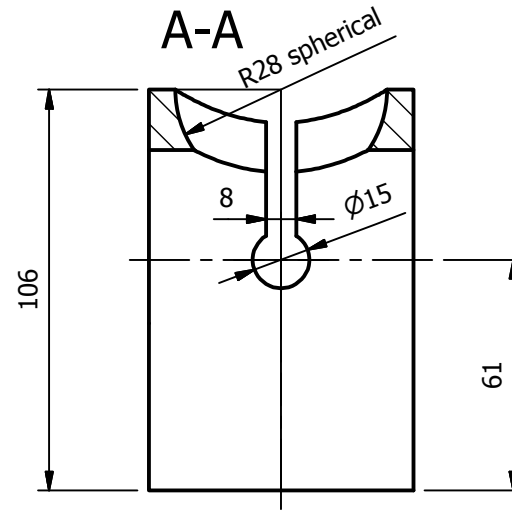
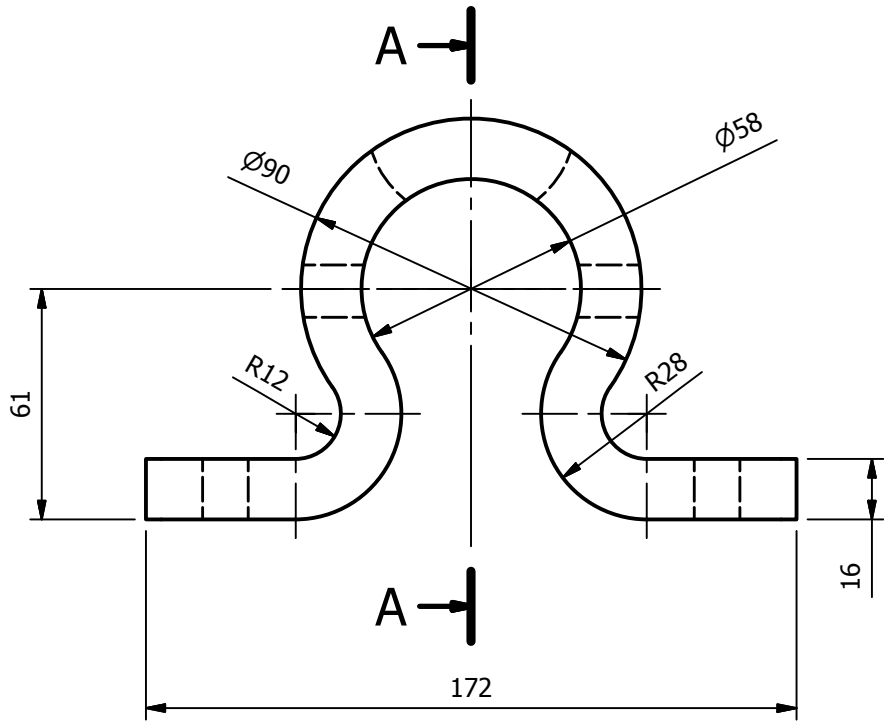

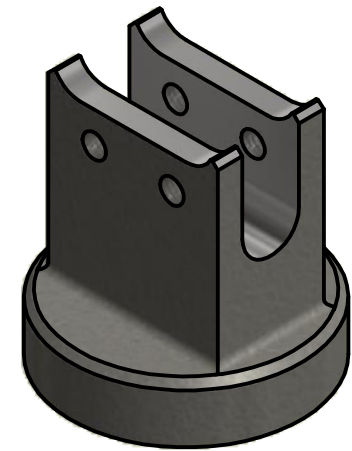
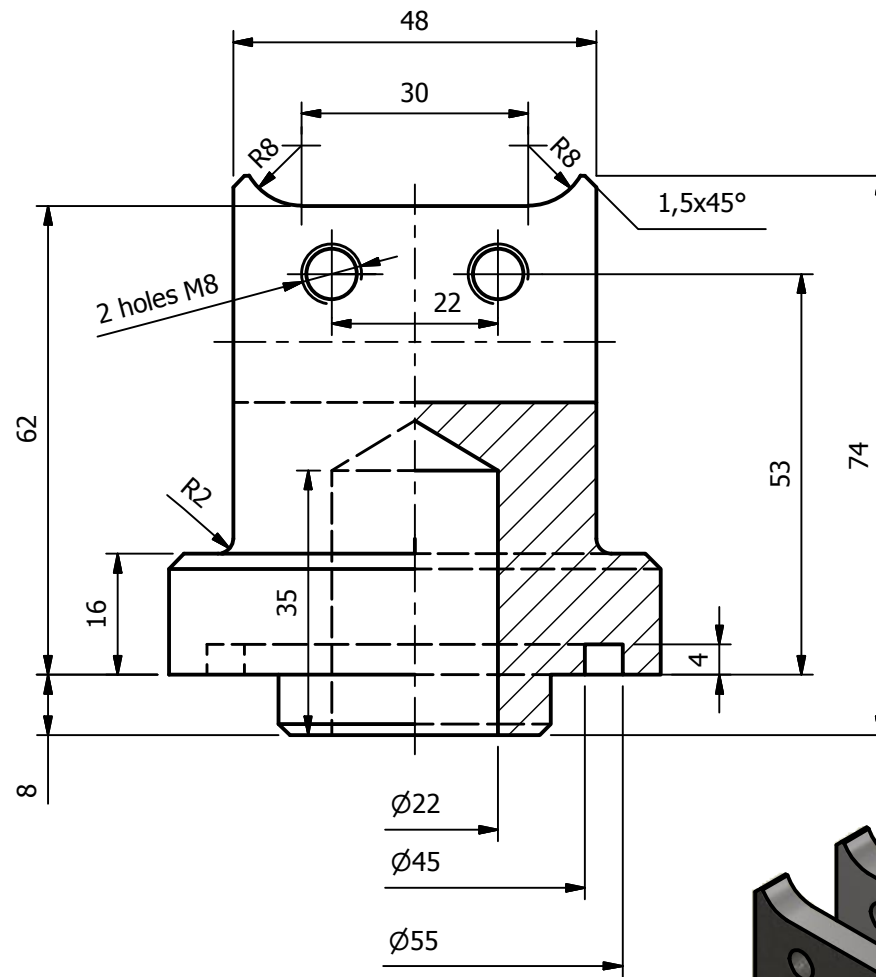
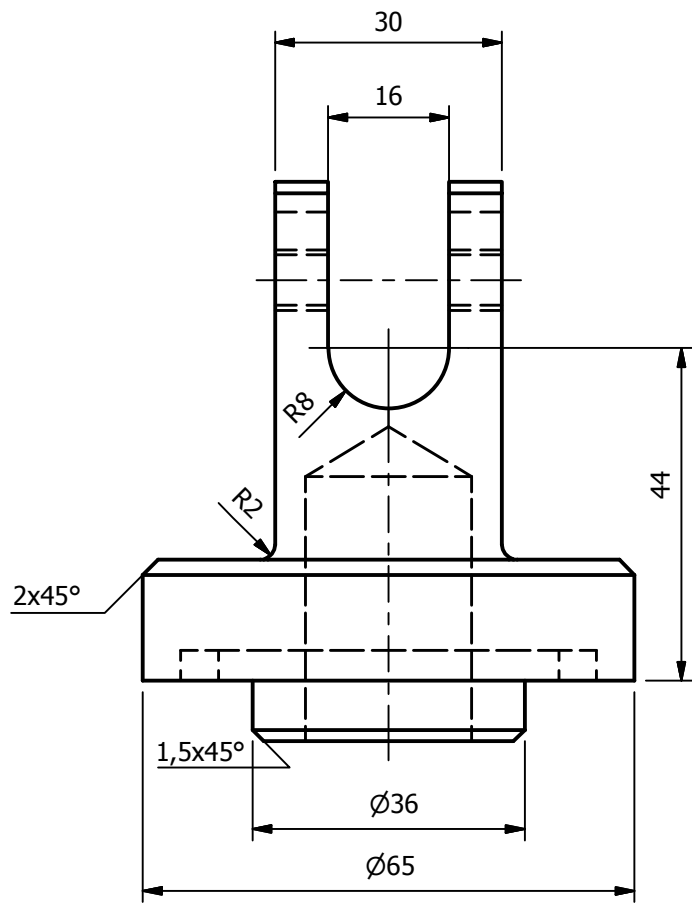

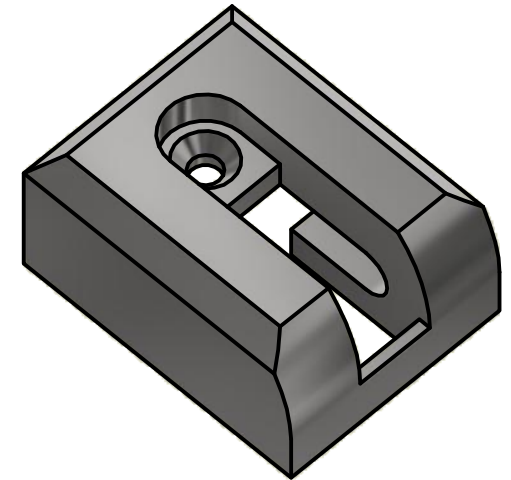
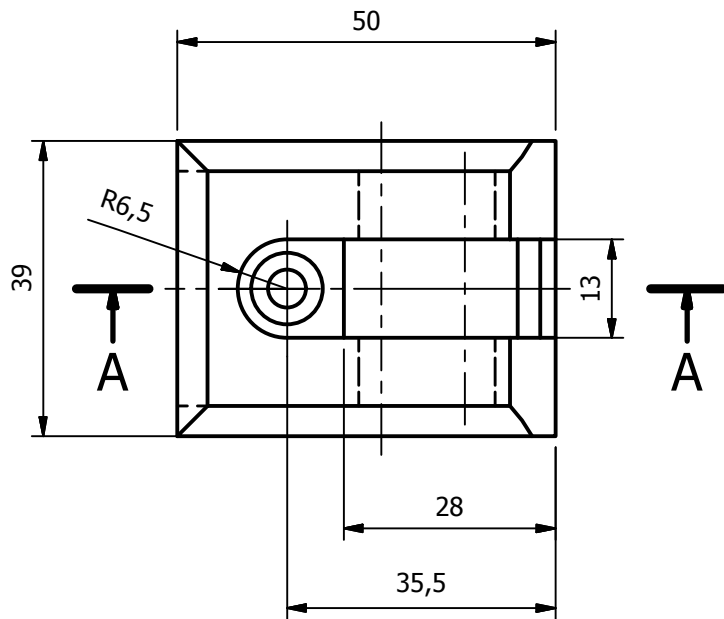
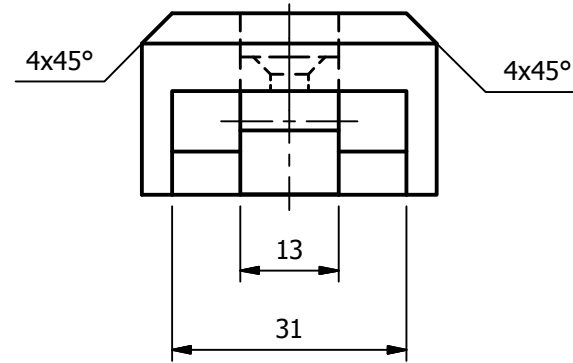
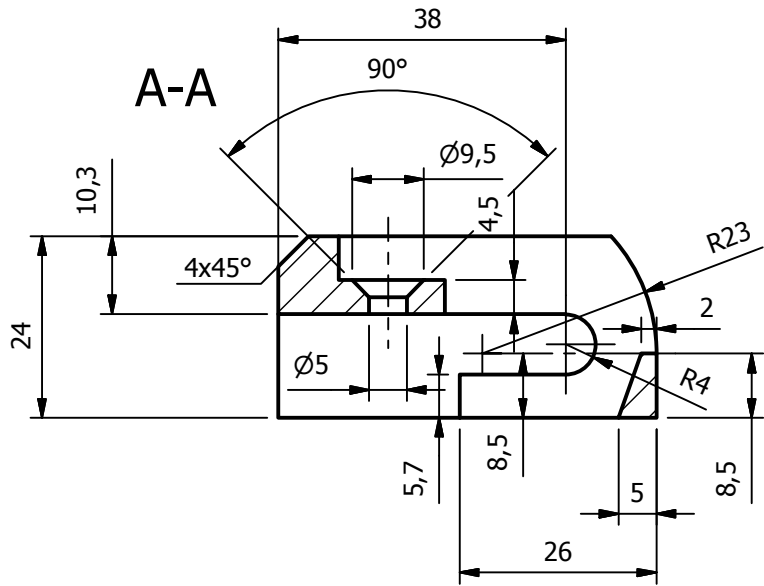

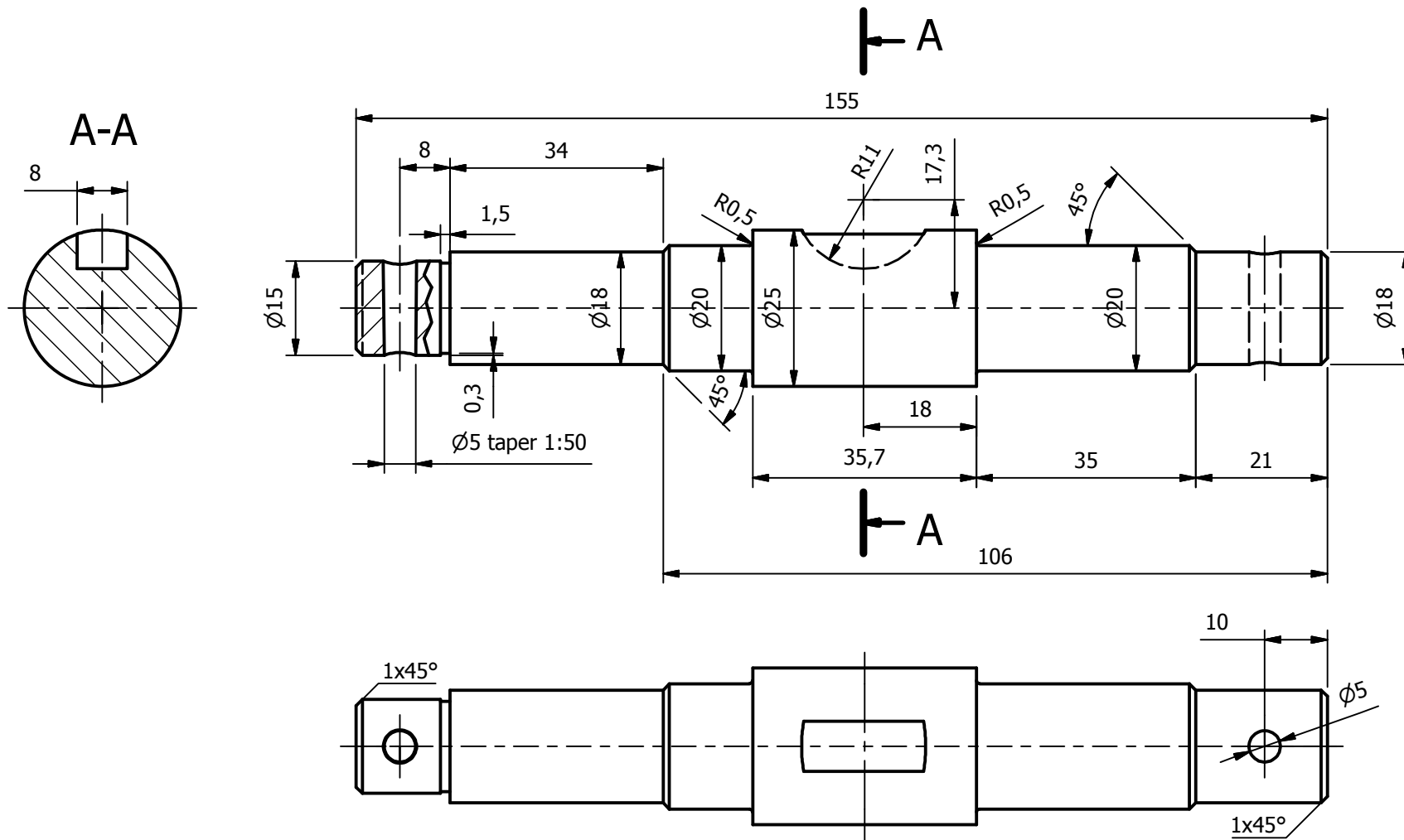

Note: The taper K is the rapport of the diameter difference of two cross sections of a cone and the axial distance between the sections

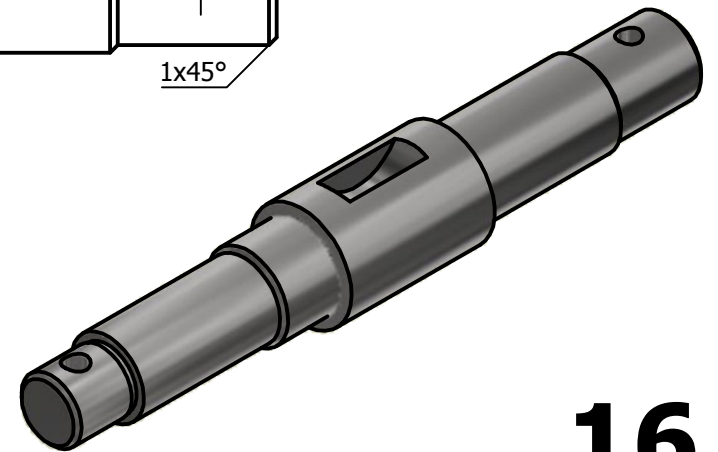

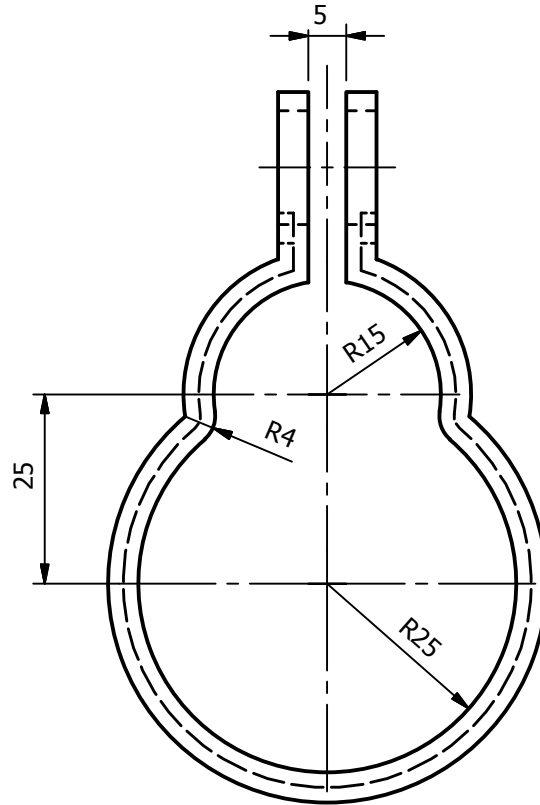
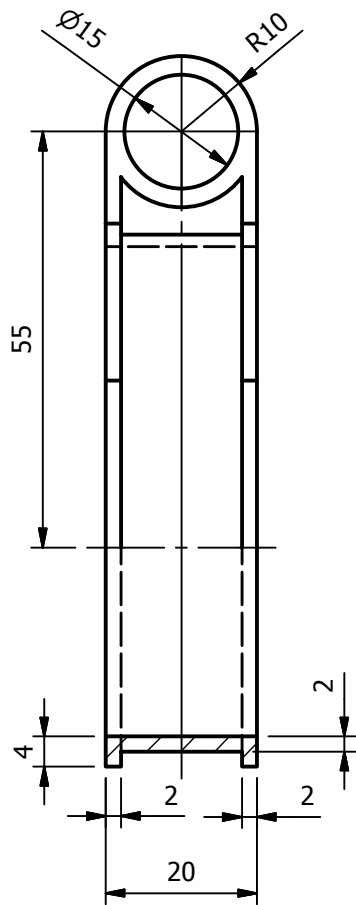

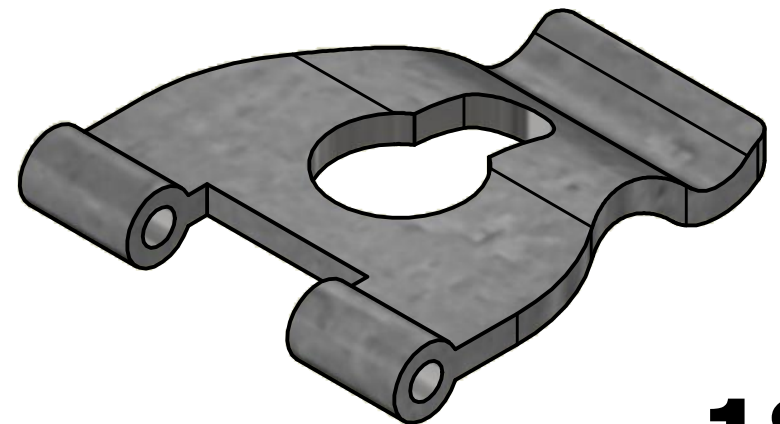
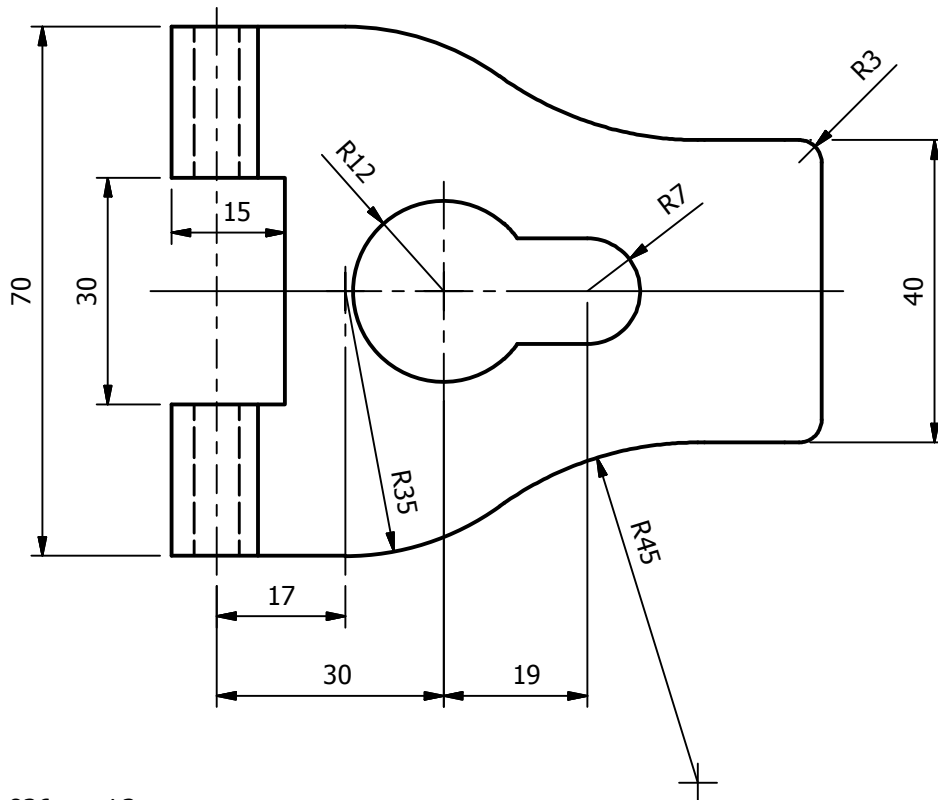
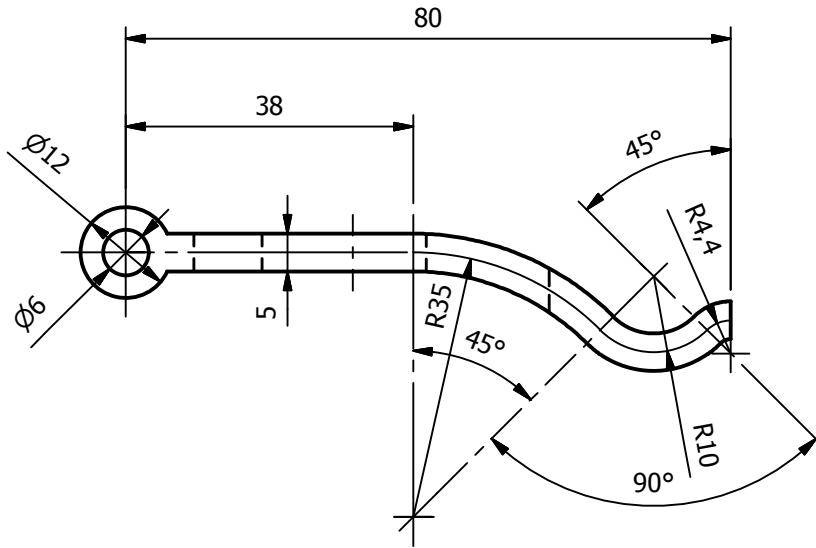

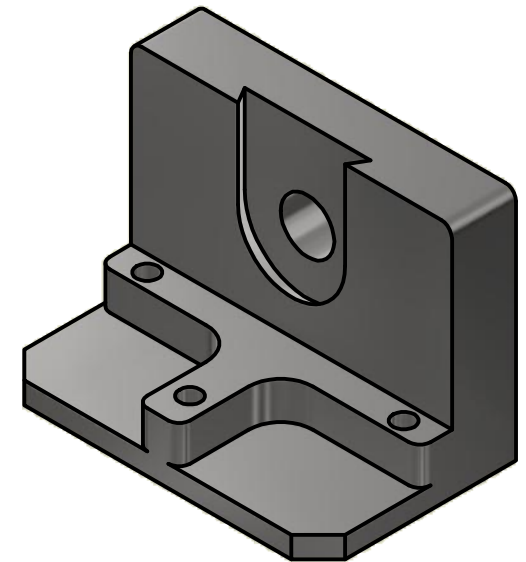
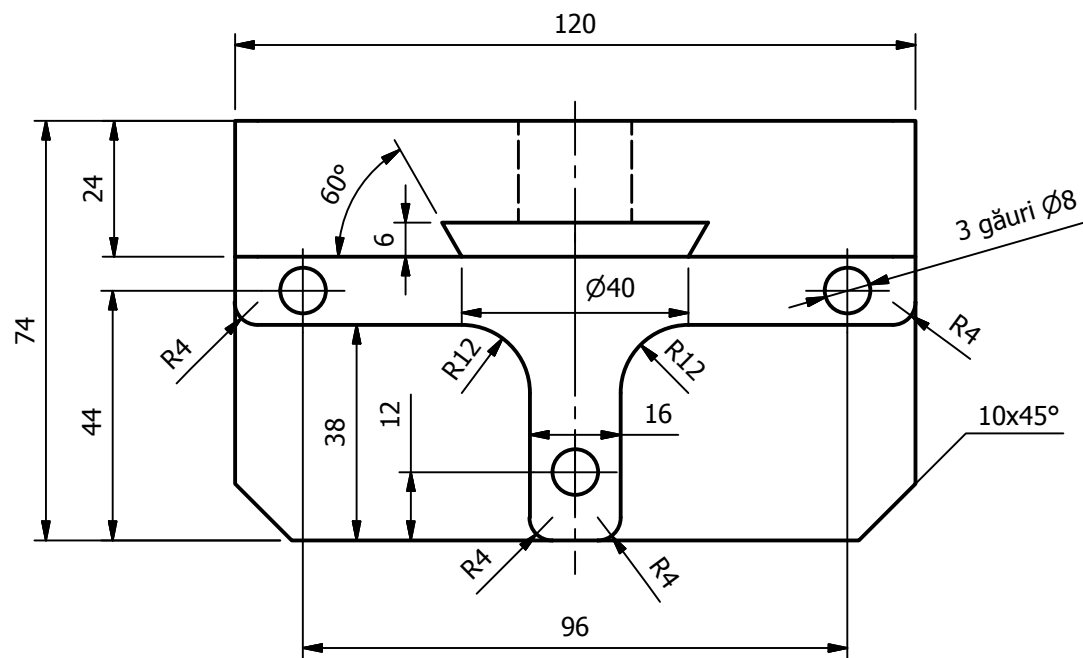
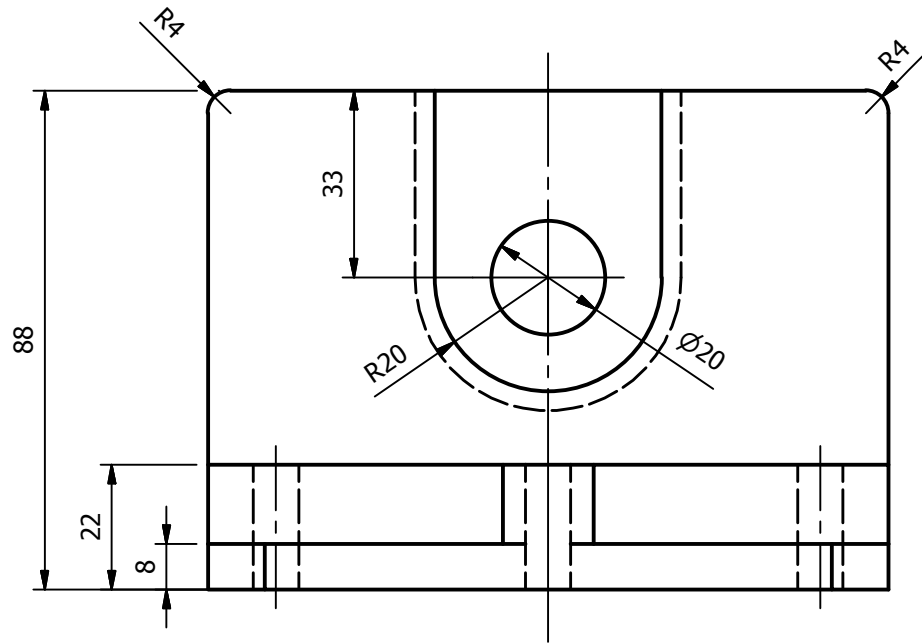

307781.318 mm³

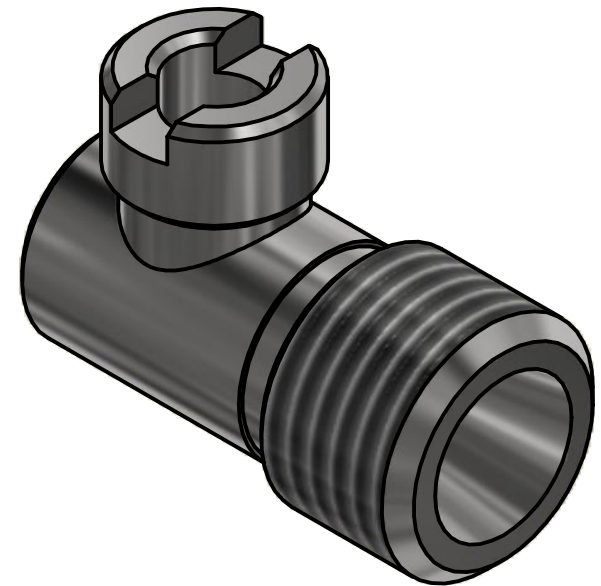
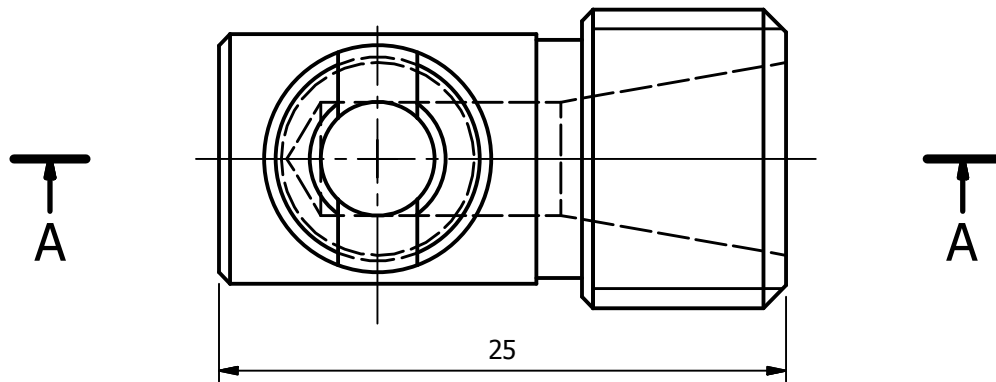
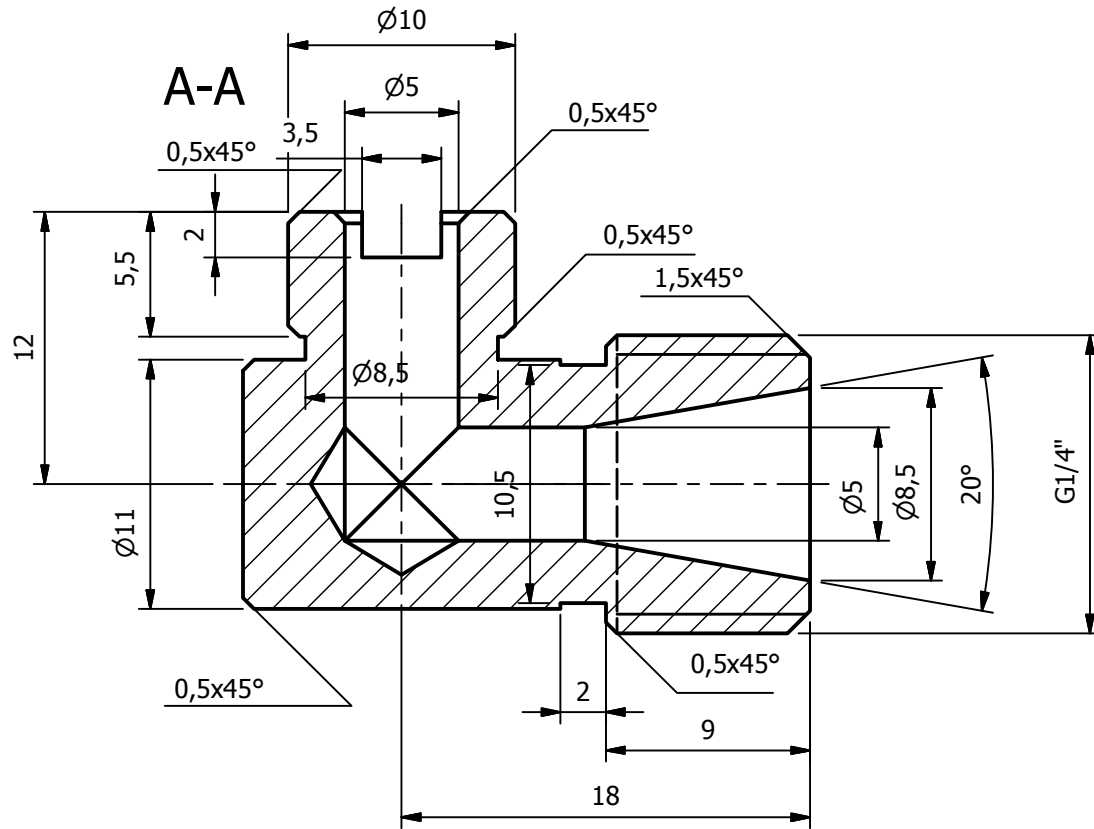

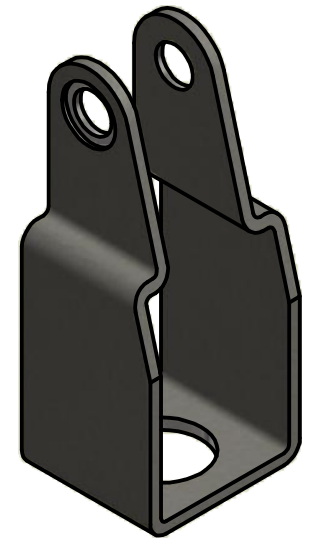
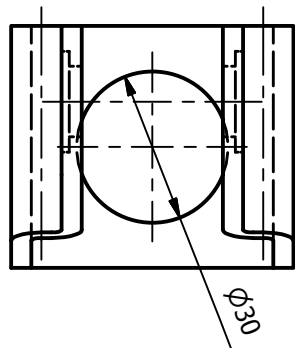
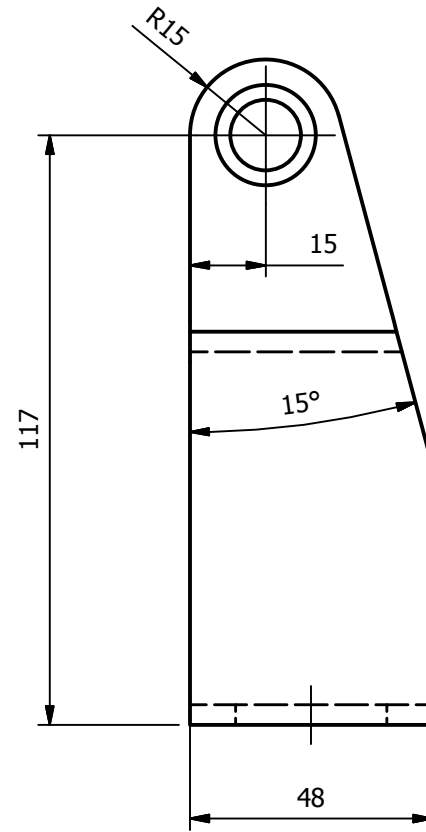
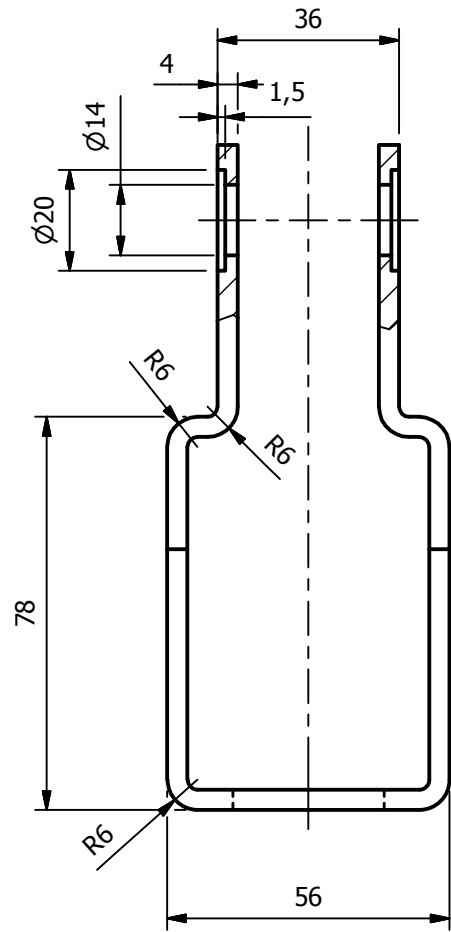

49402.496 mm³

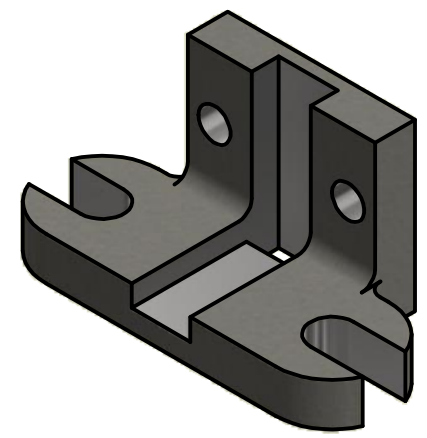
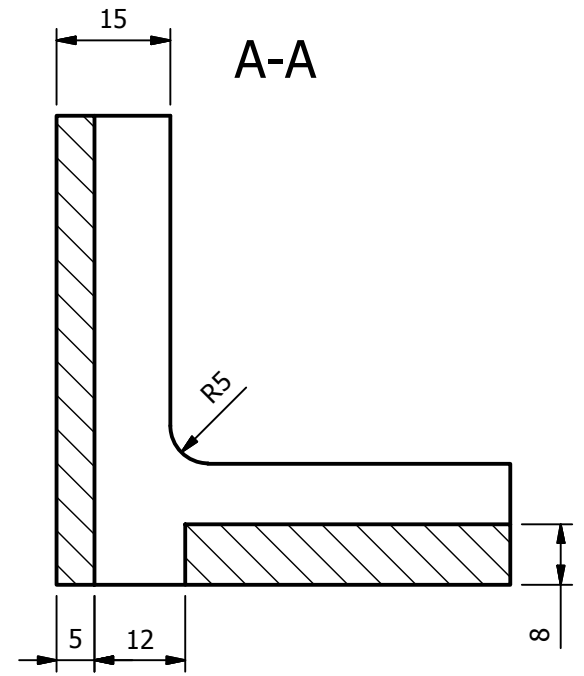
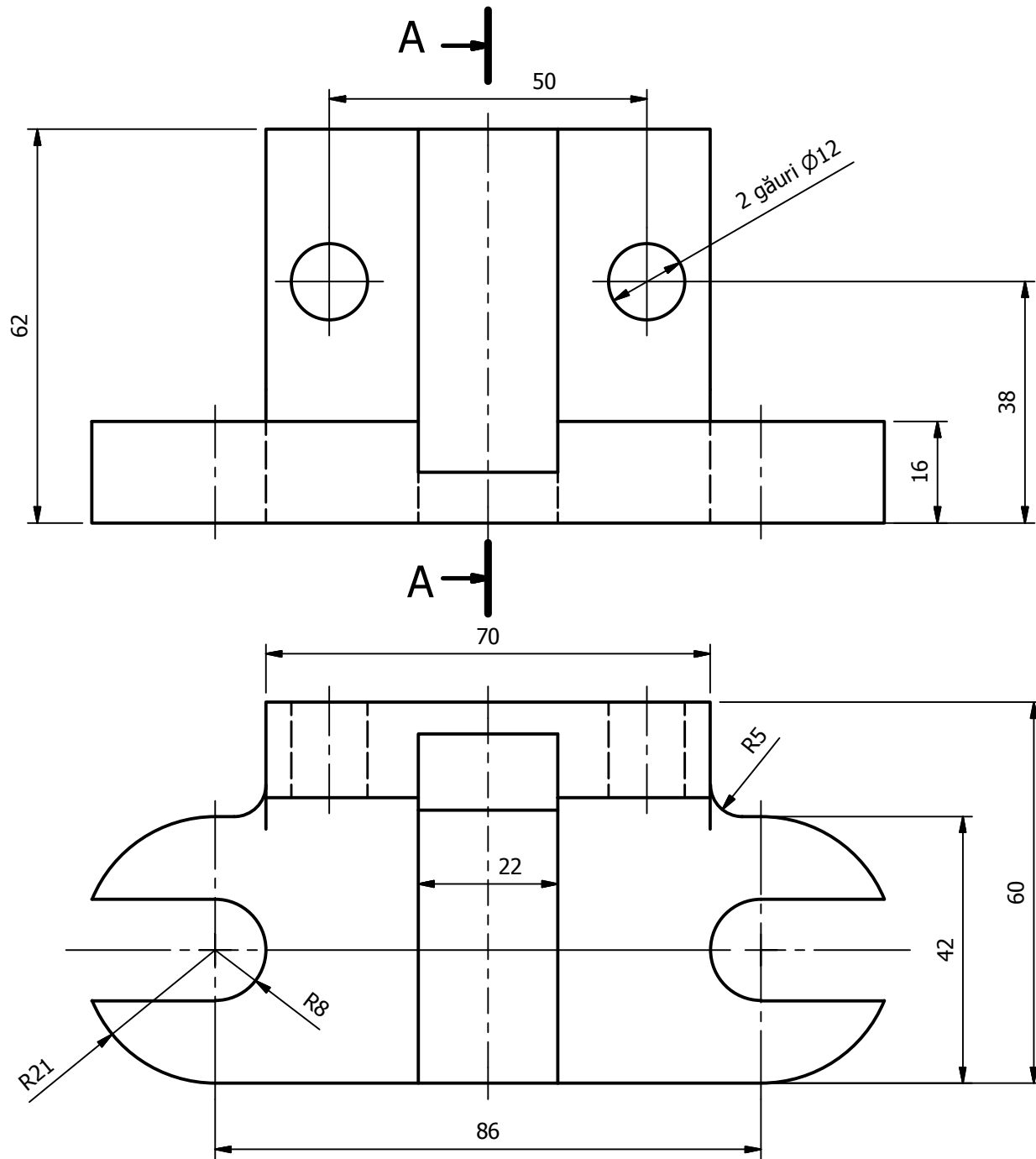

109840.625 mm³

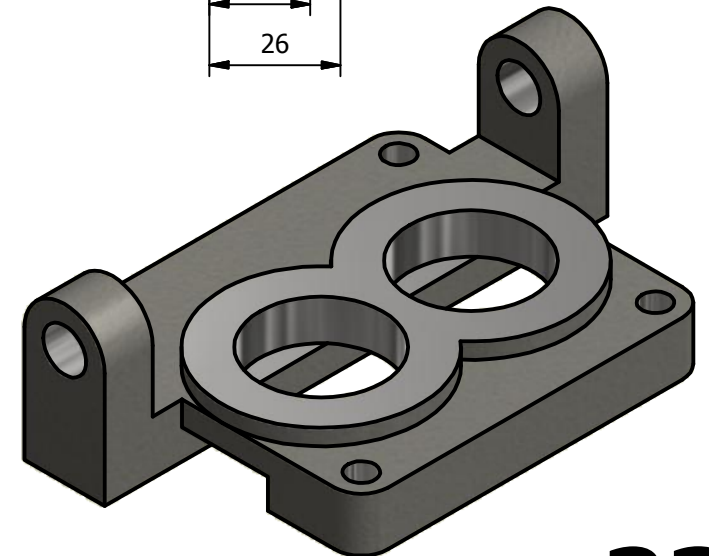
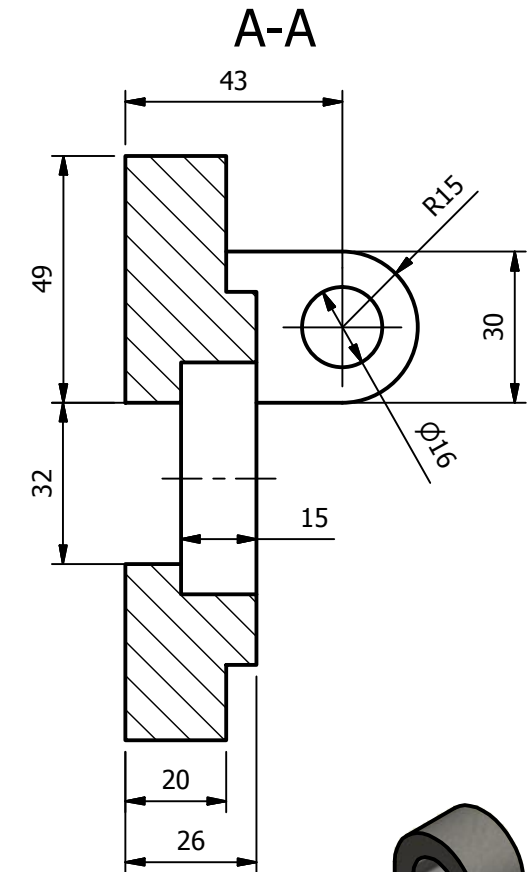
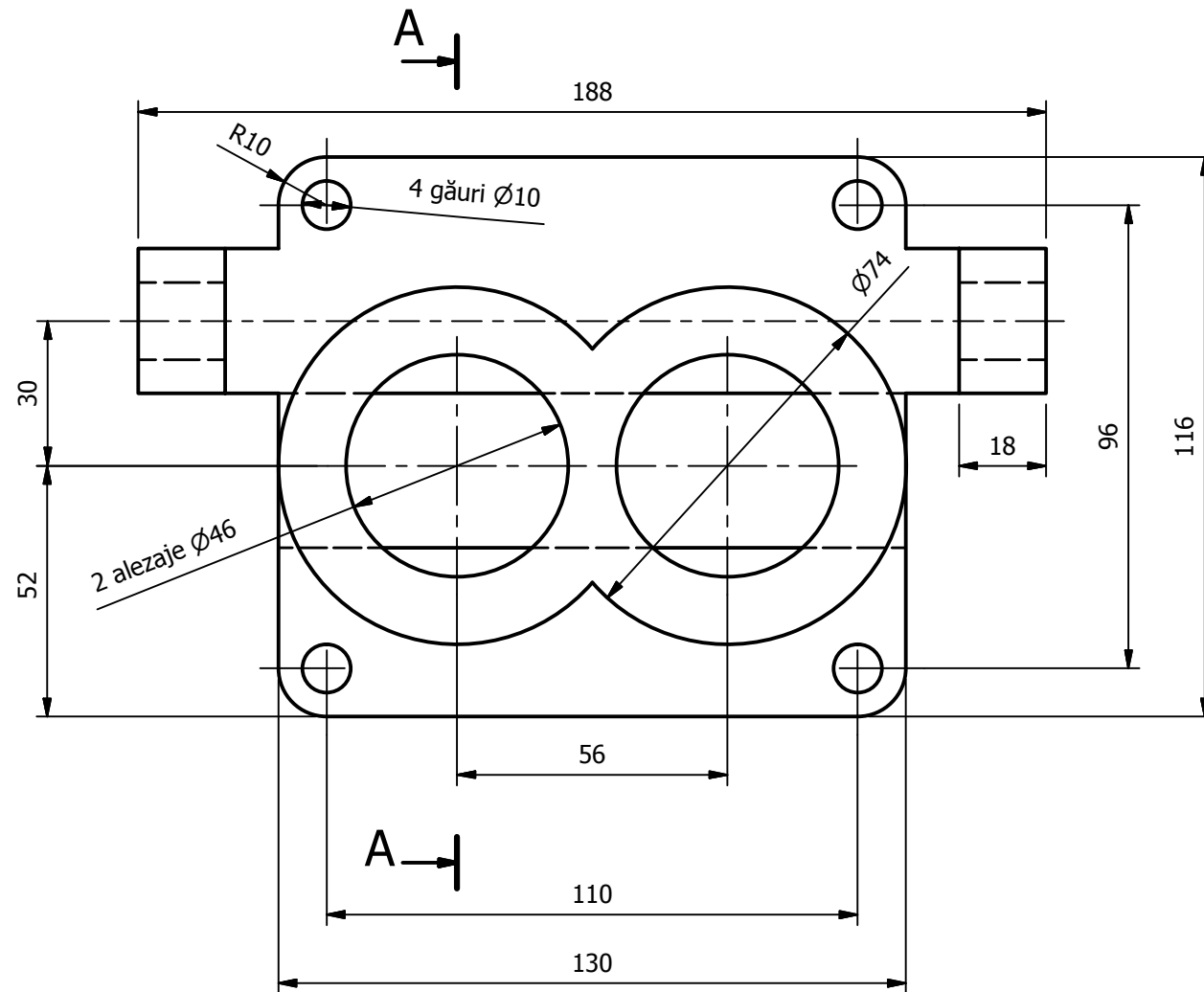

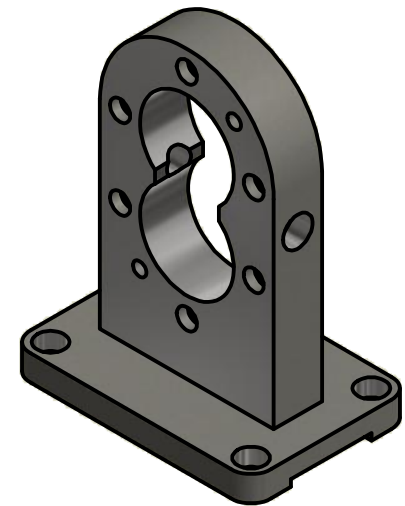
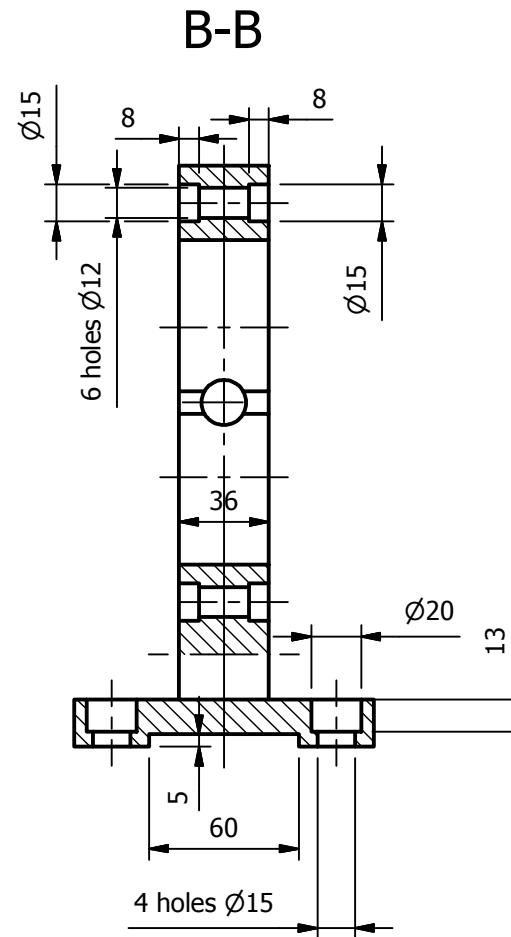
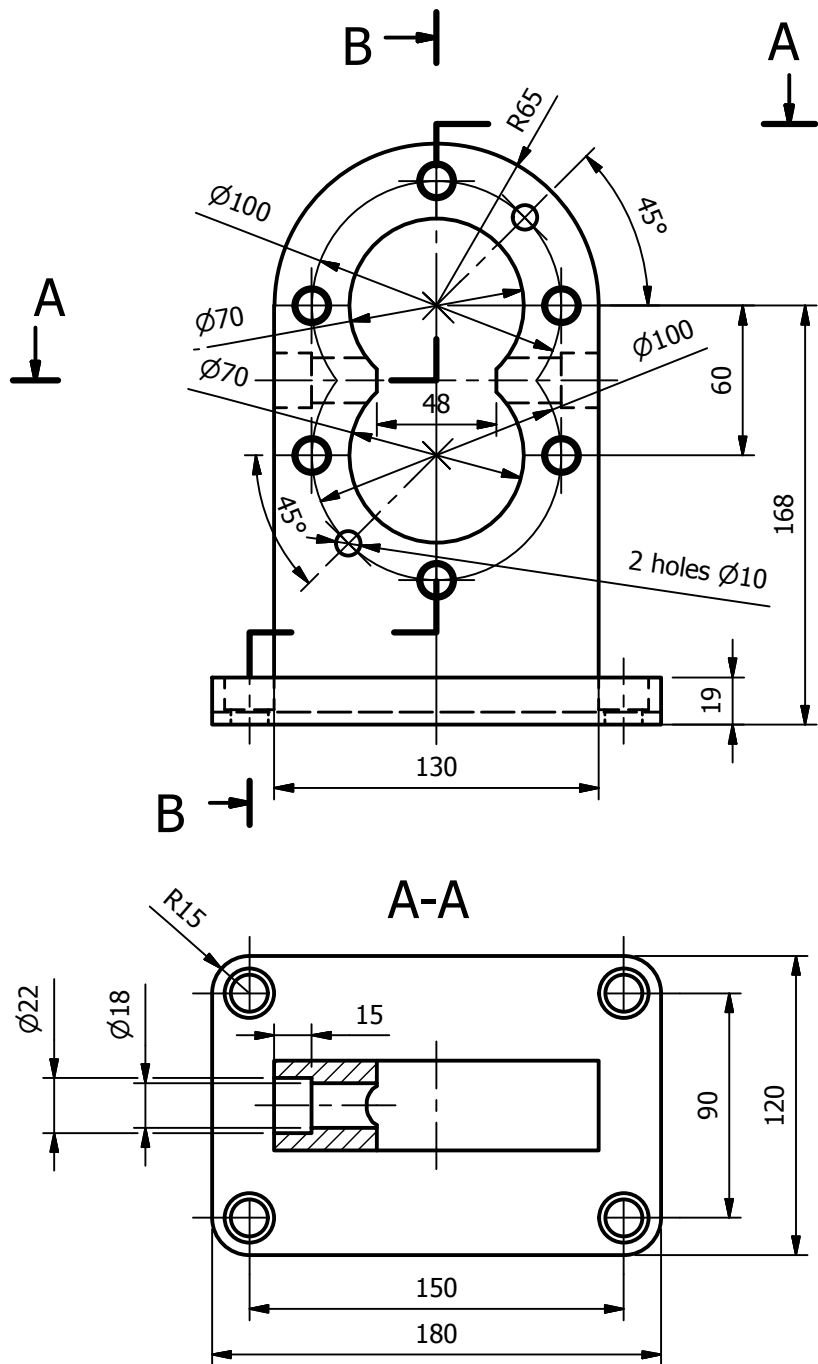

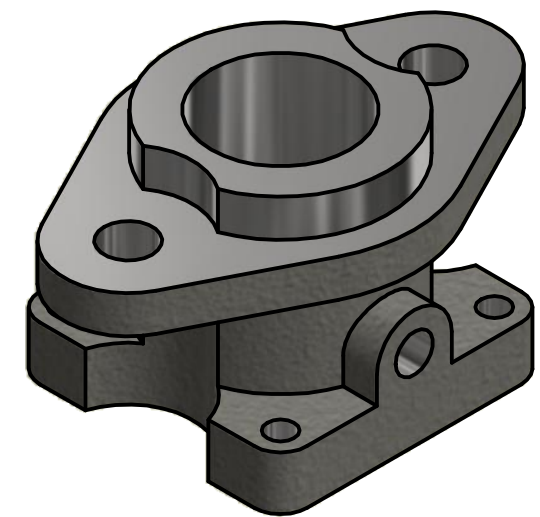
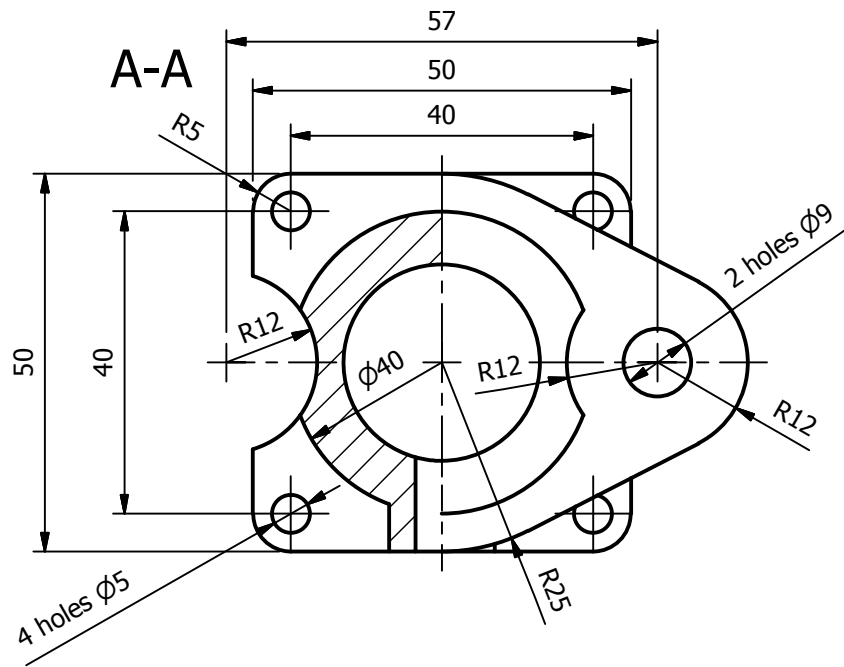
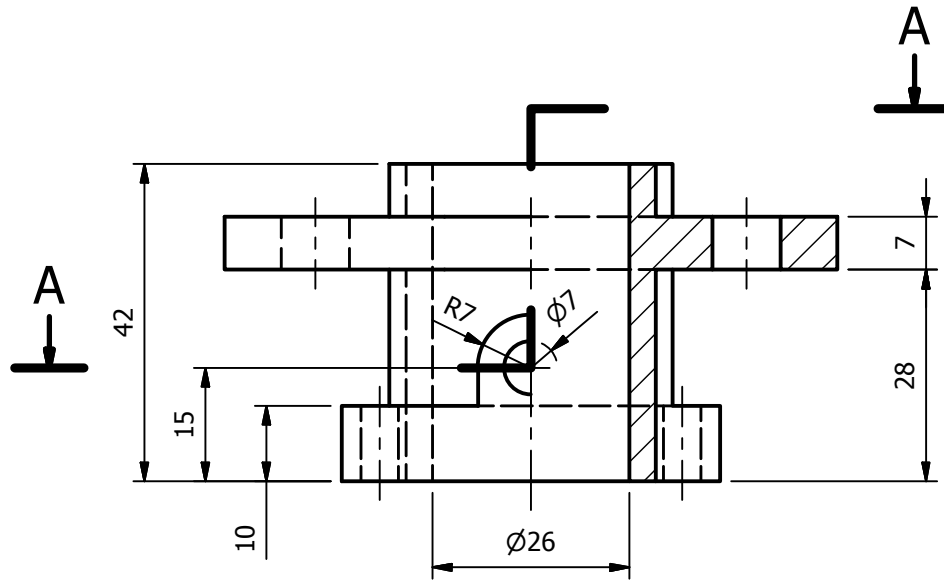

47519.002 mm³

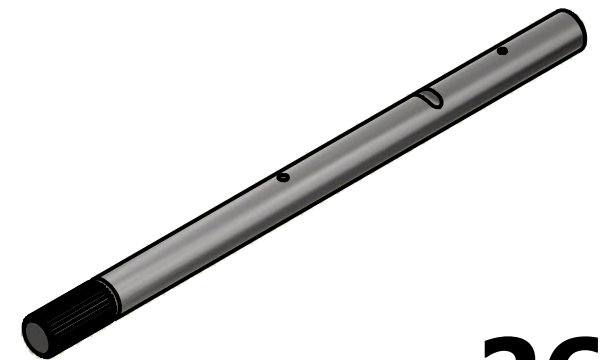
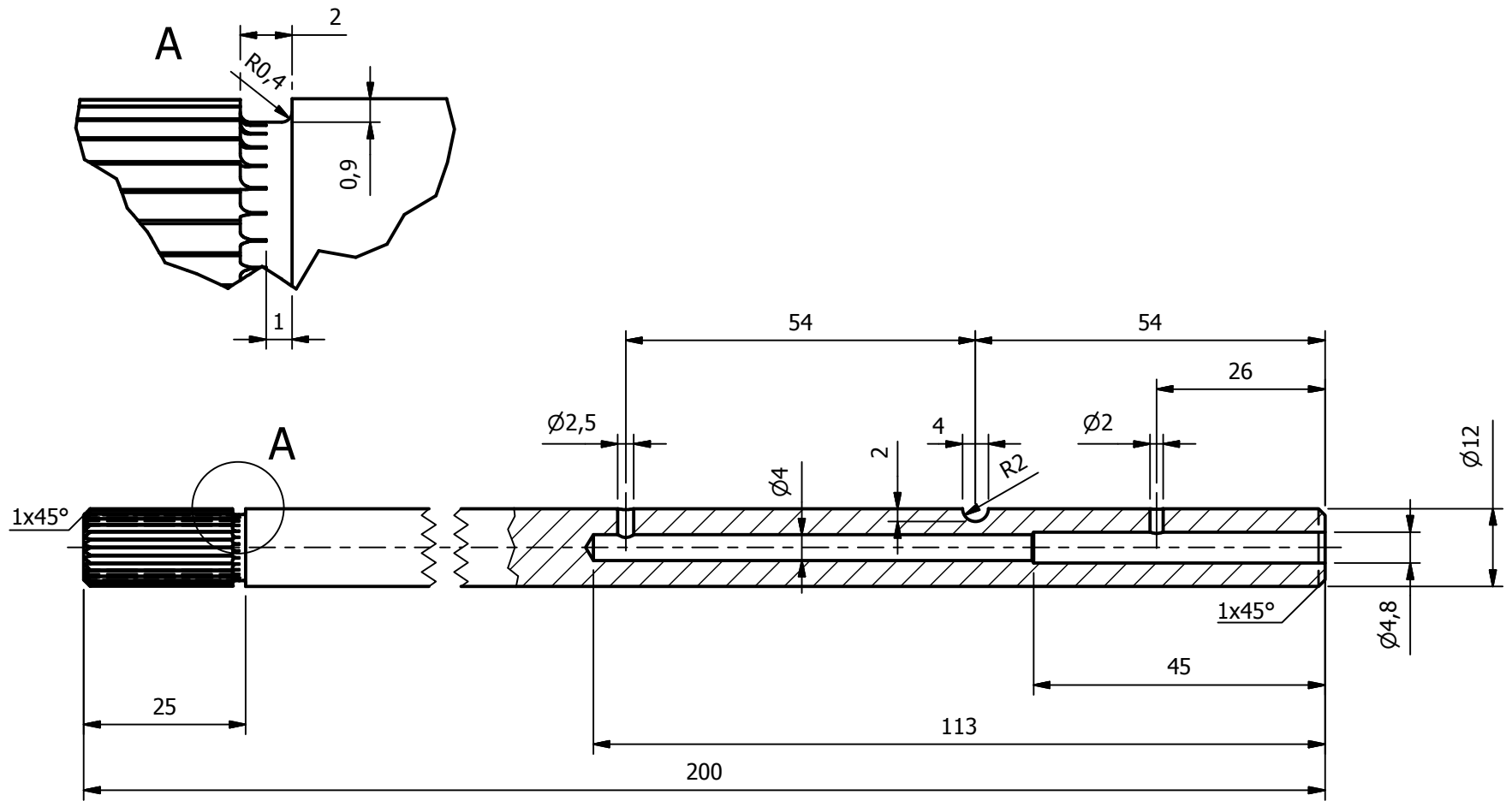

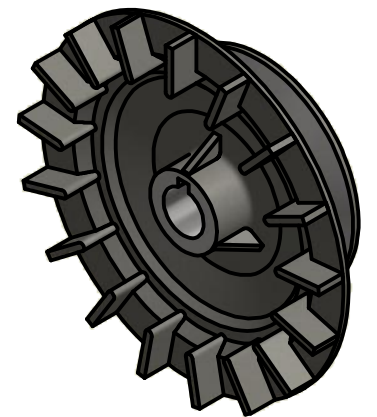
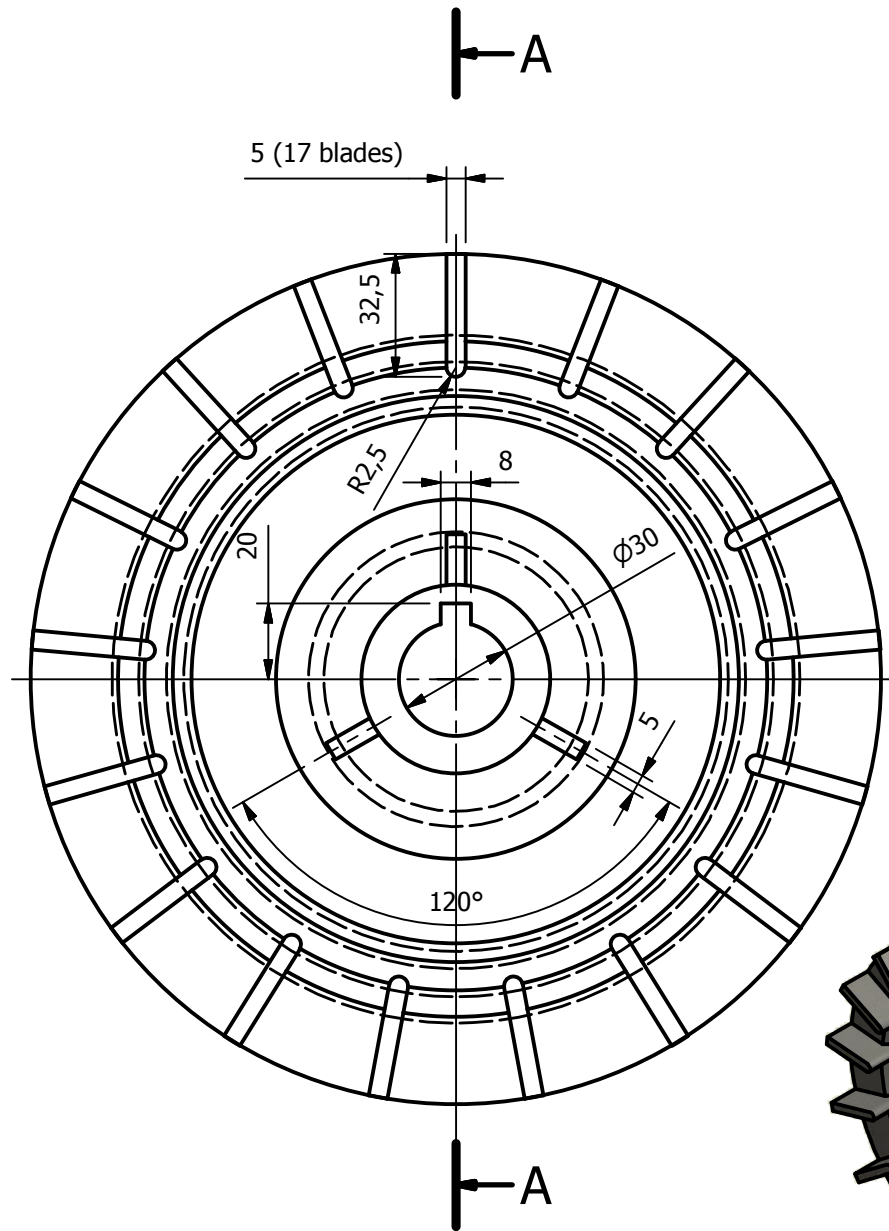
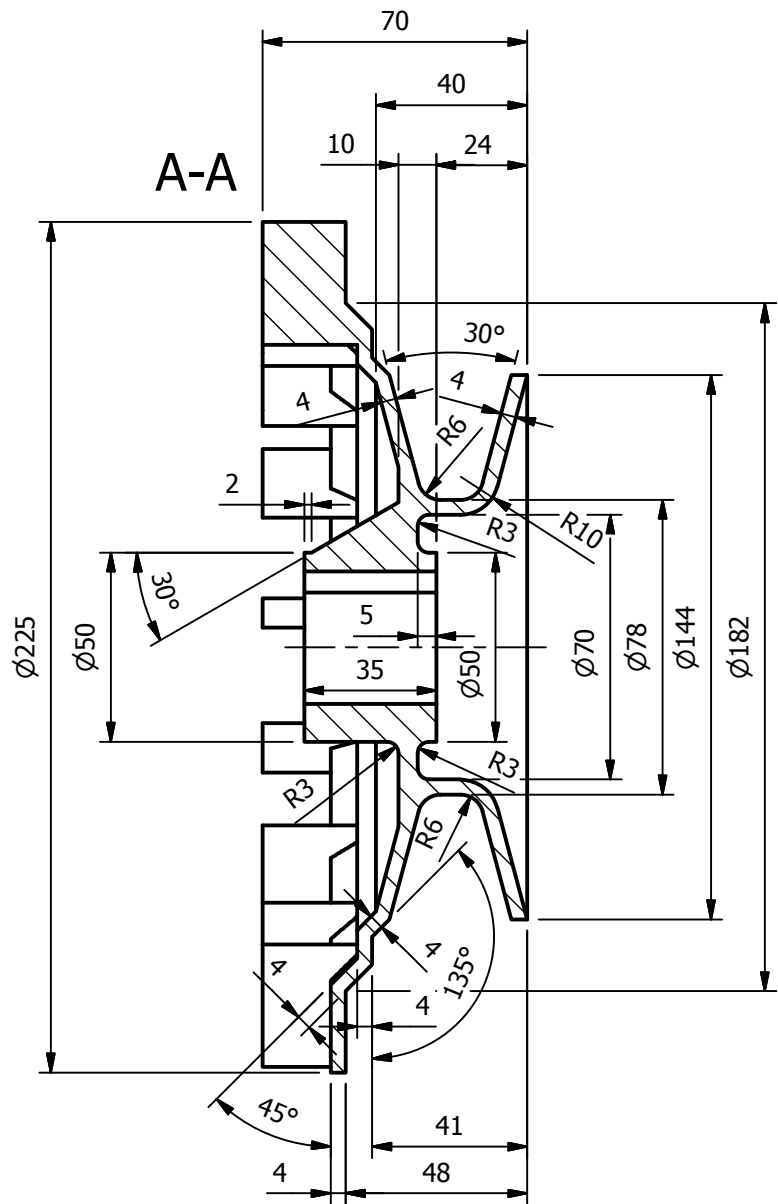

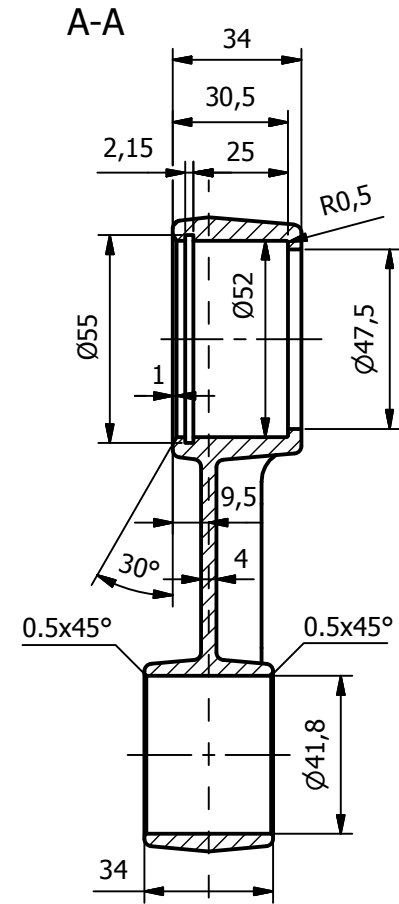
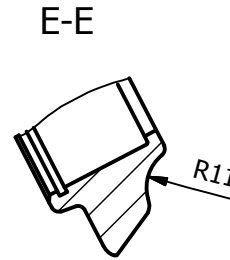
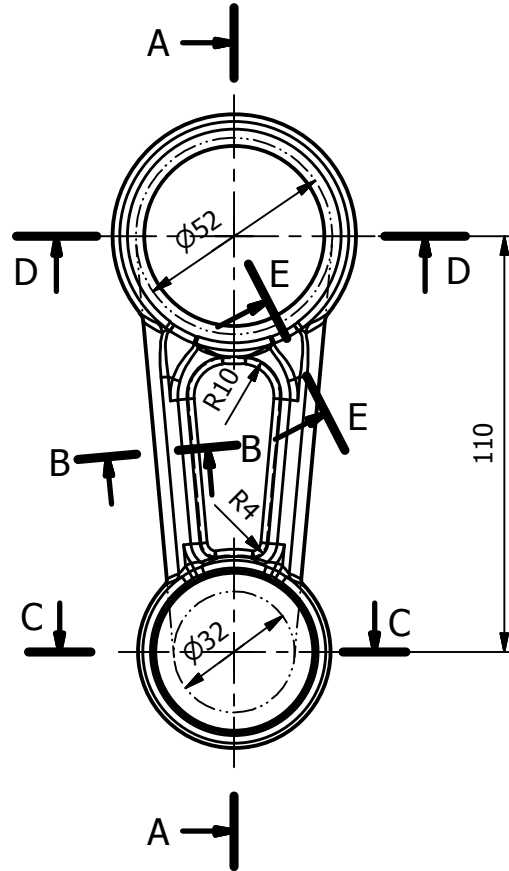
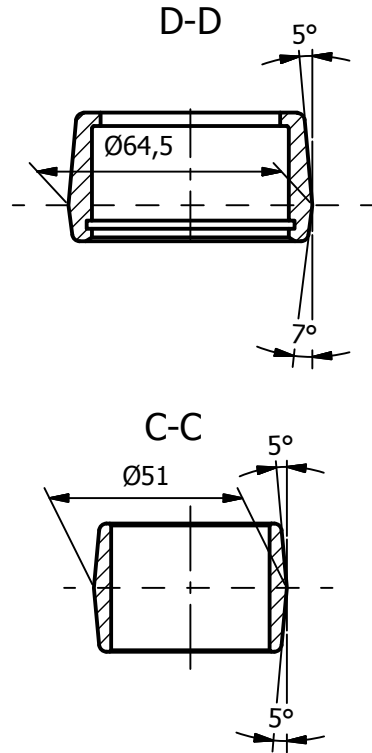
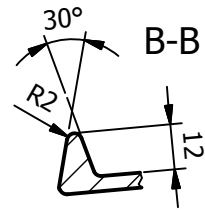

Separating Line
for forging

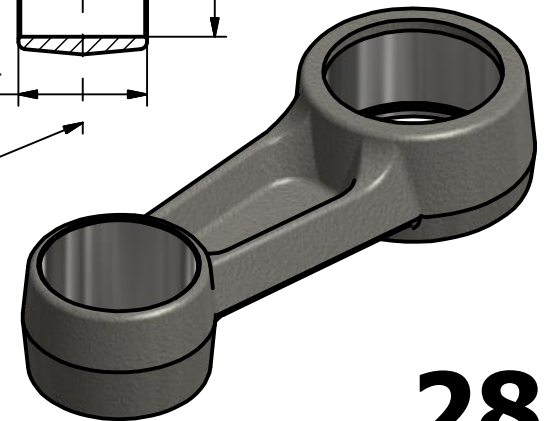

Note: All undimensioned radii are R2

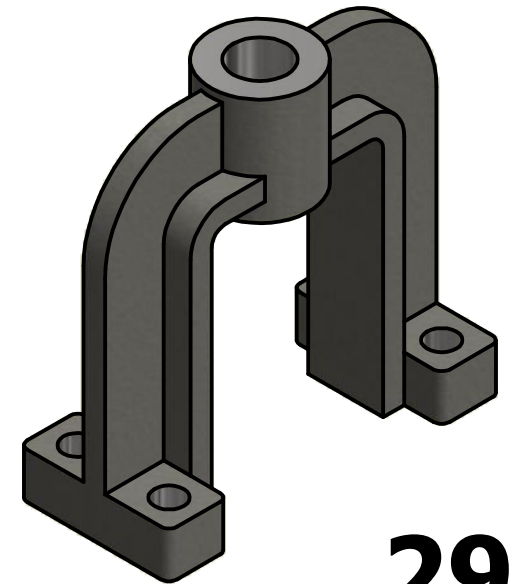
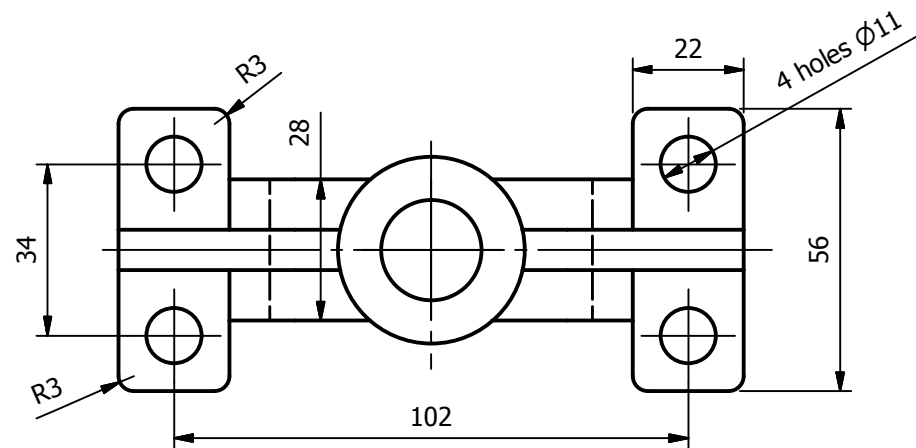
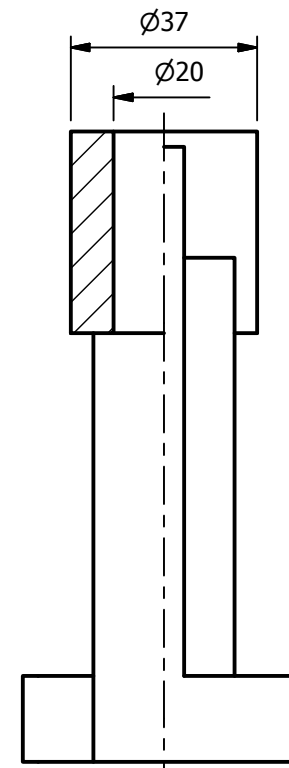
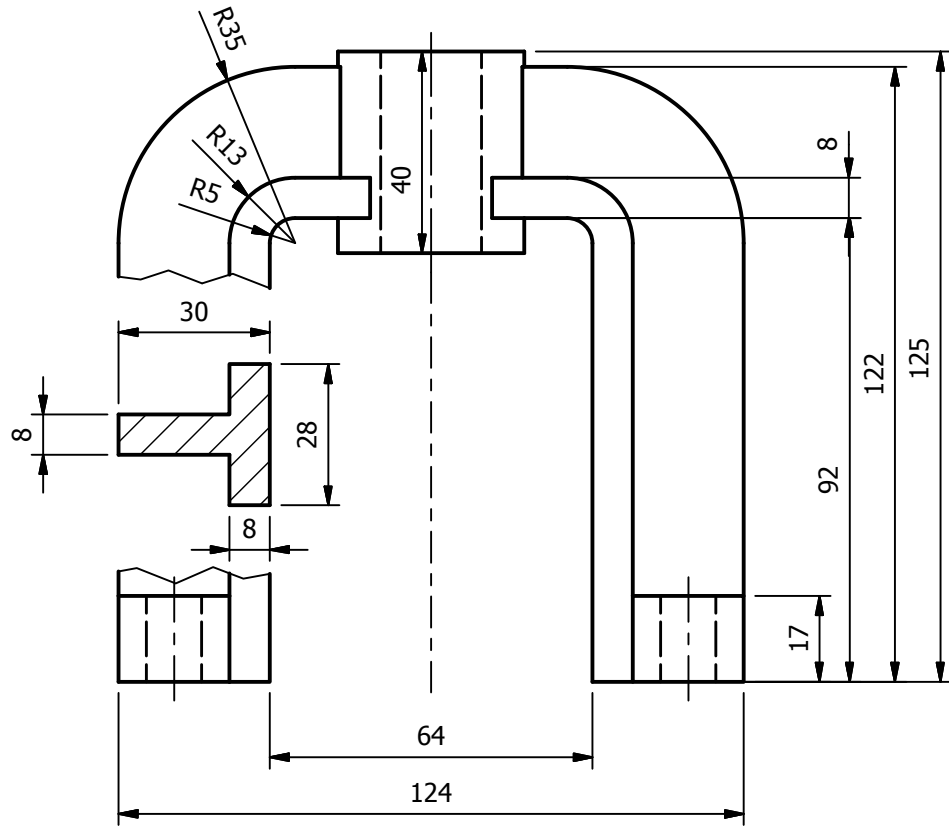

156557.366 mm³

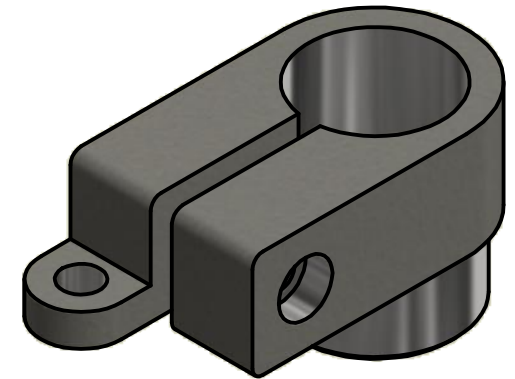
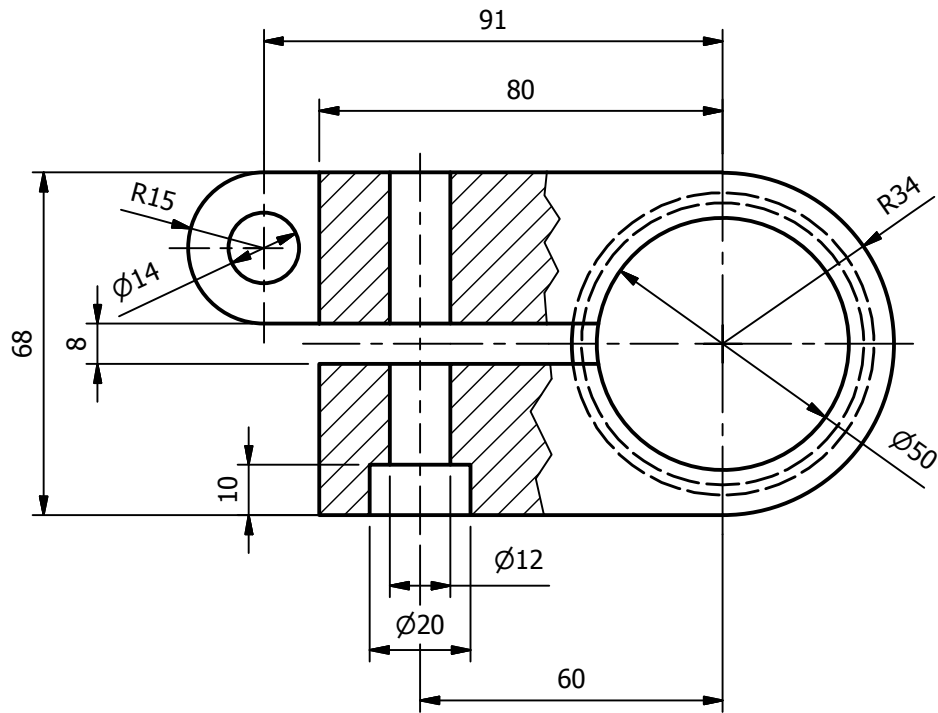
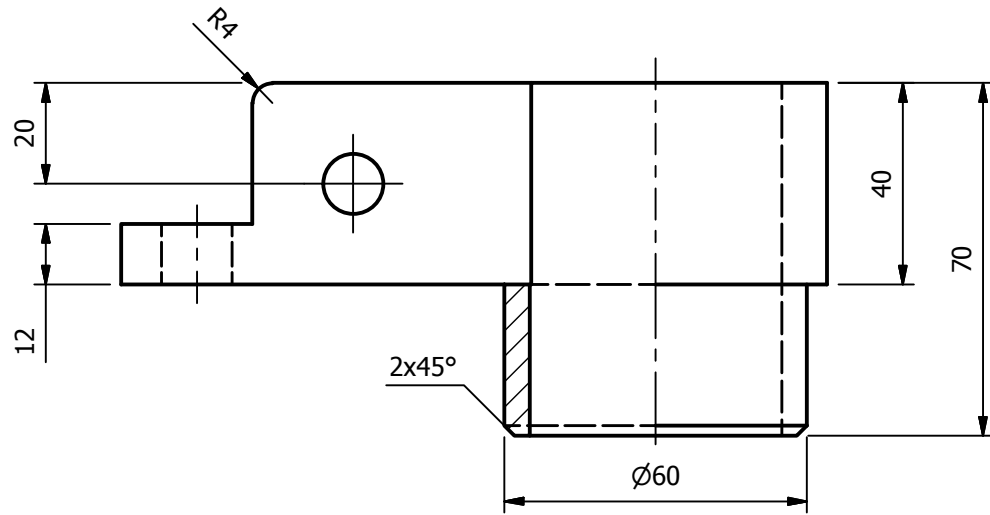

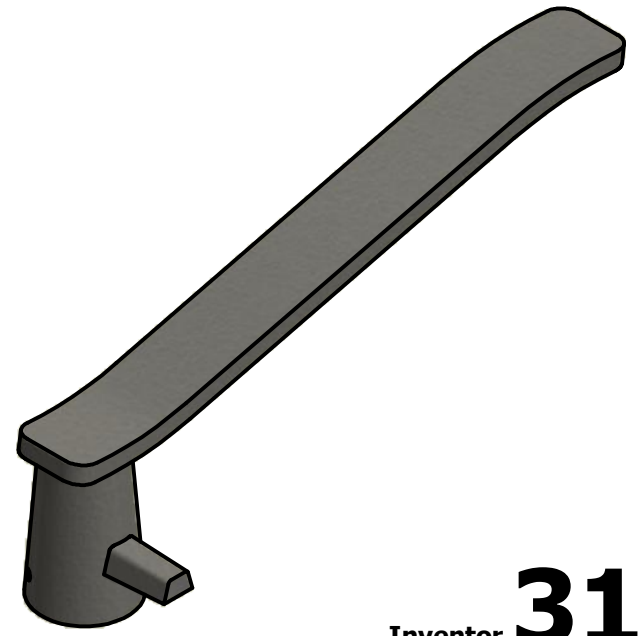
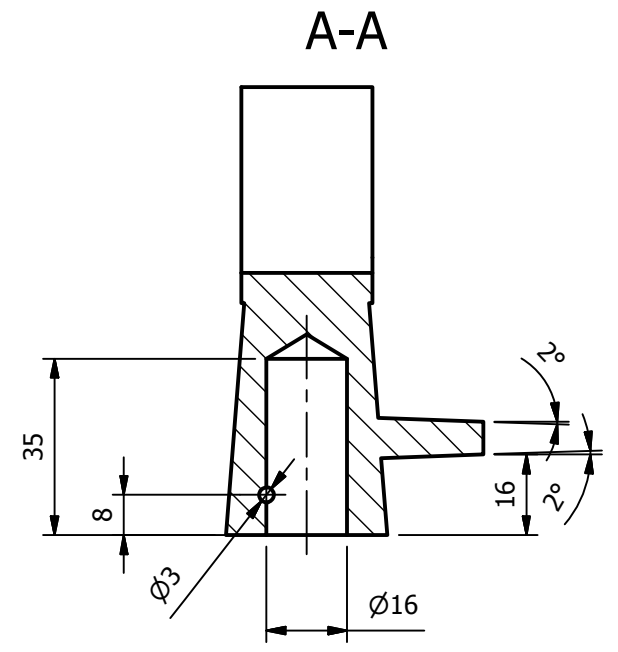
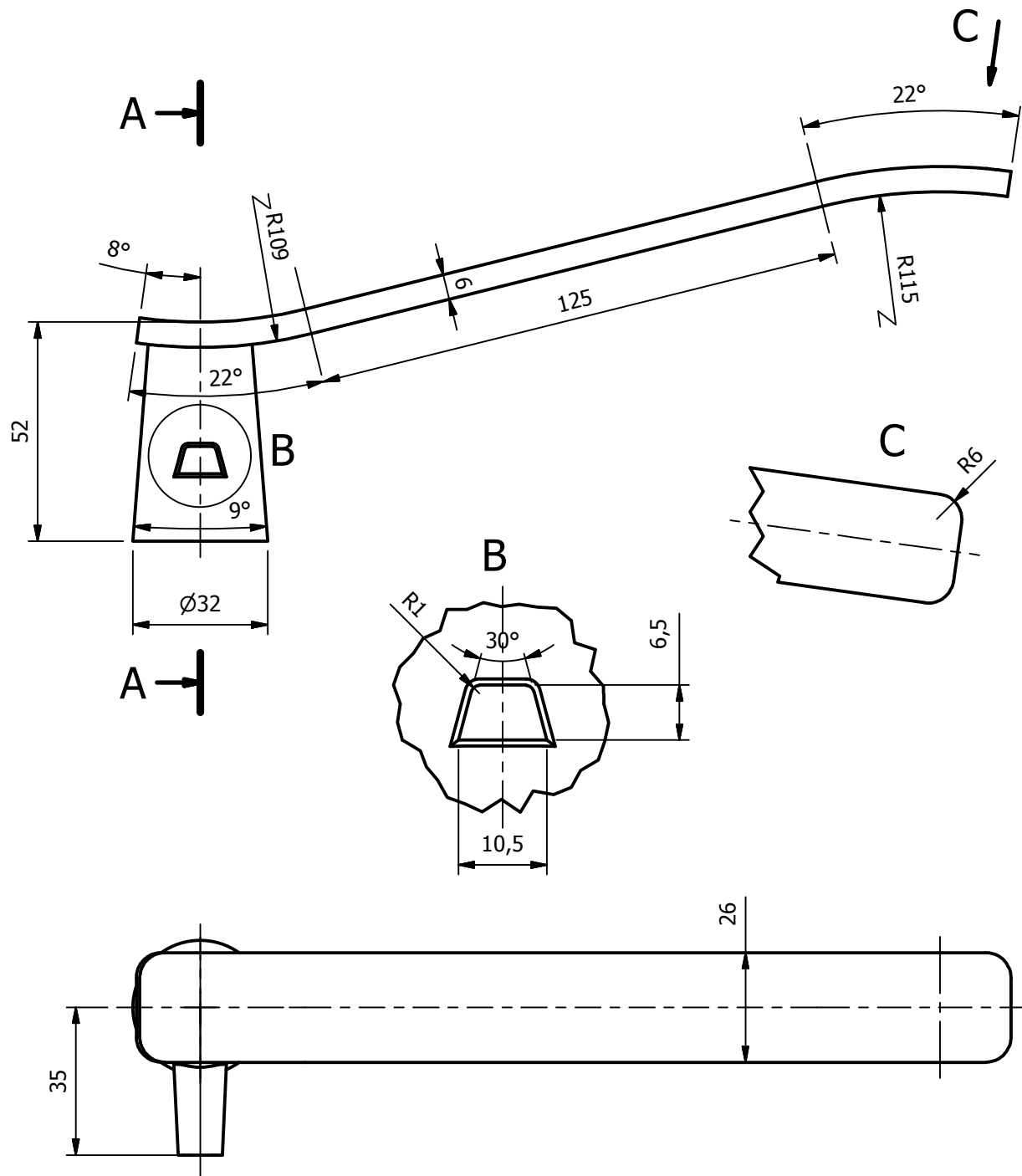

56011.601 mm³

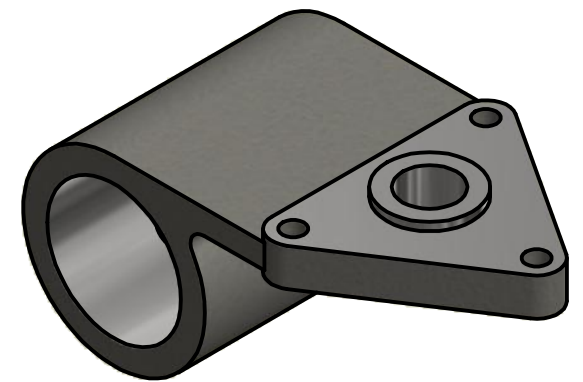
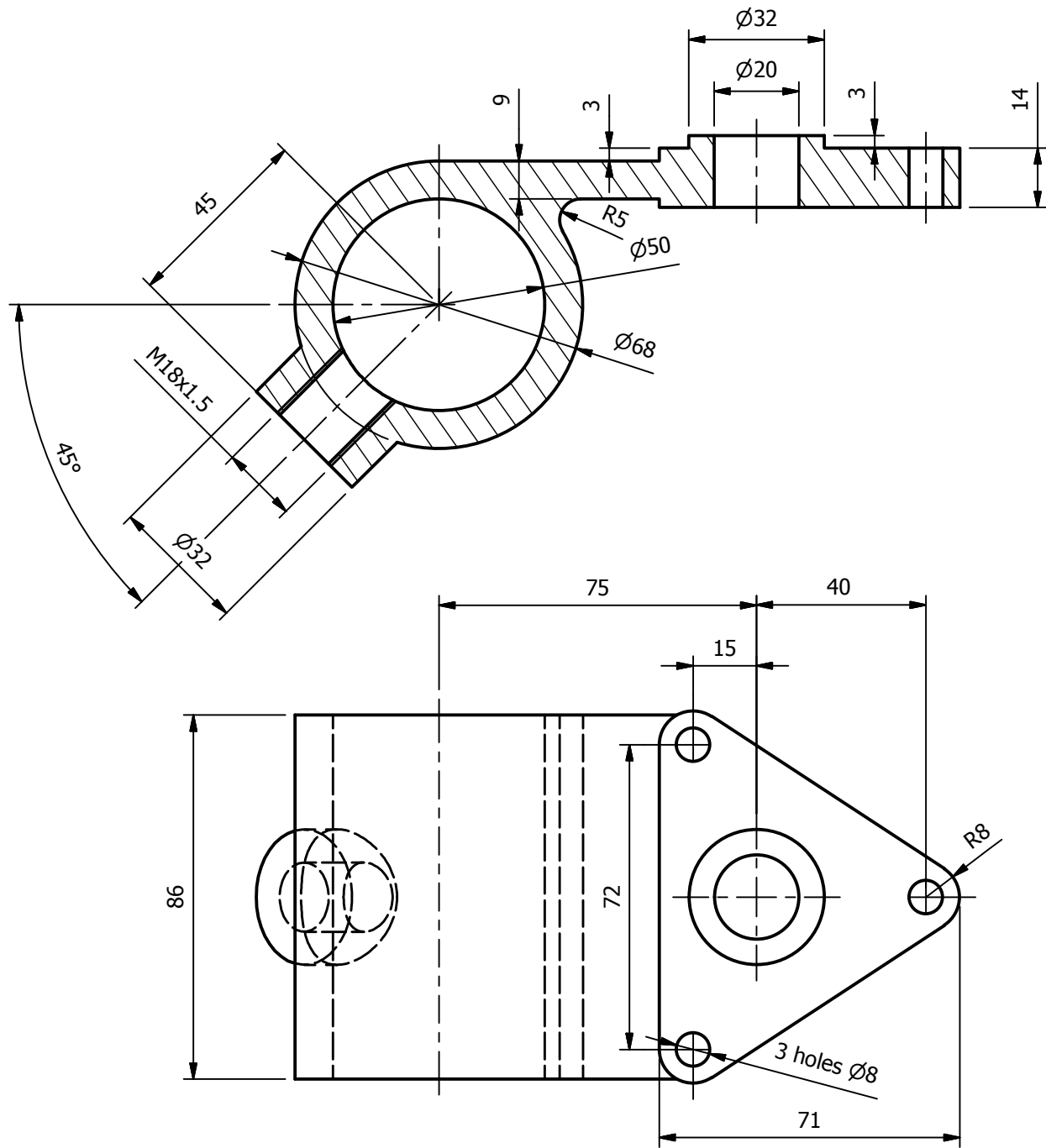

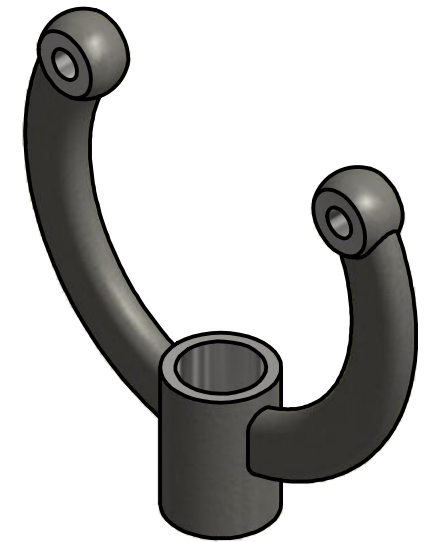
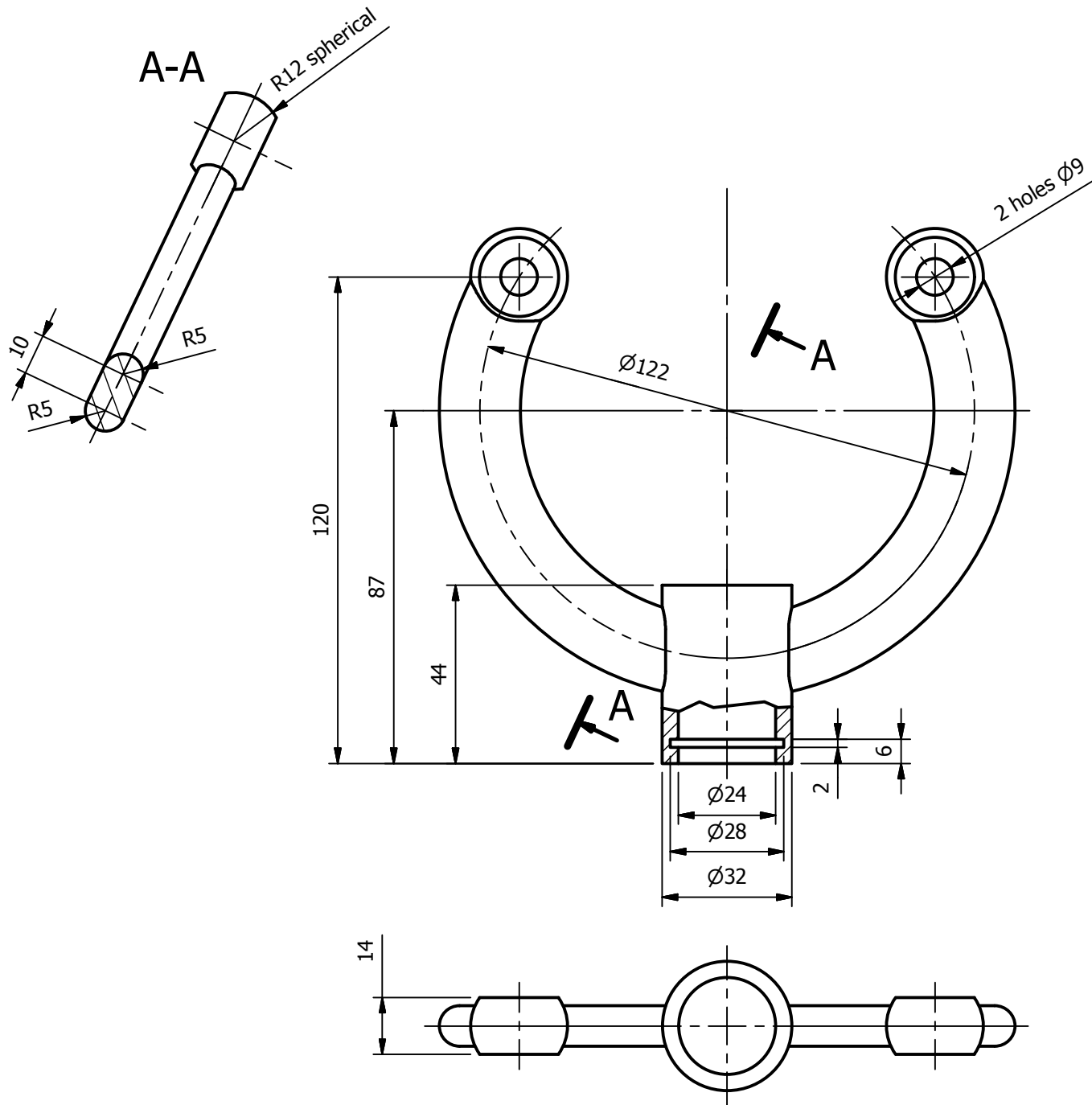

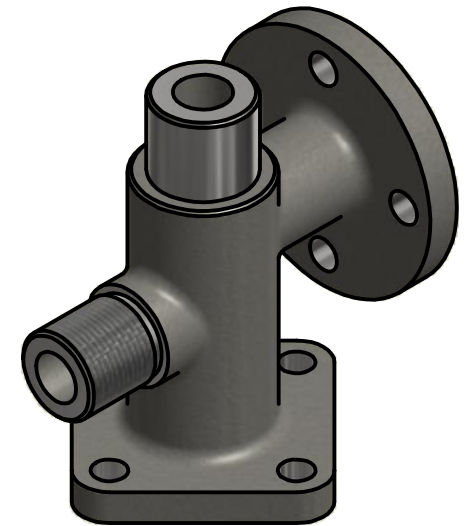
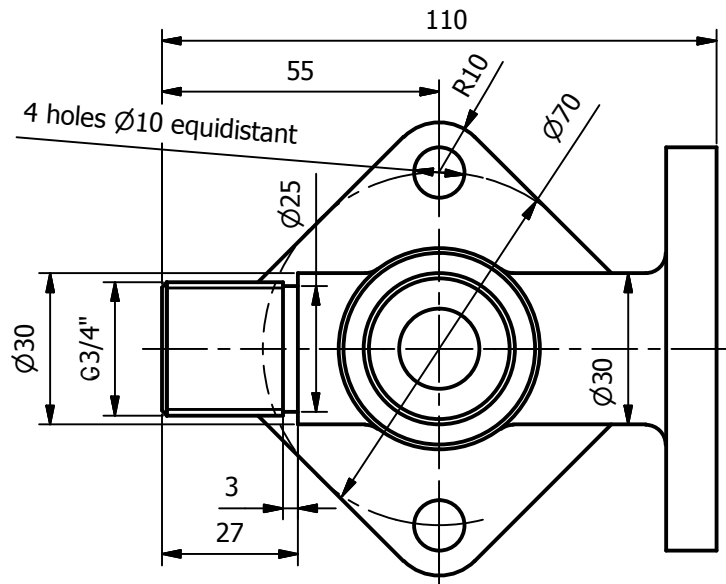
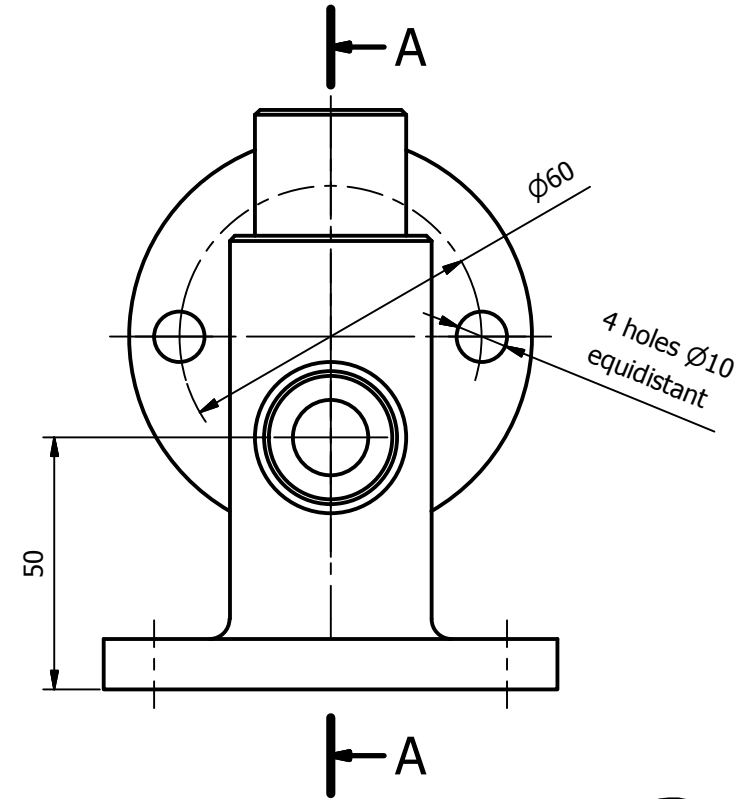
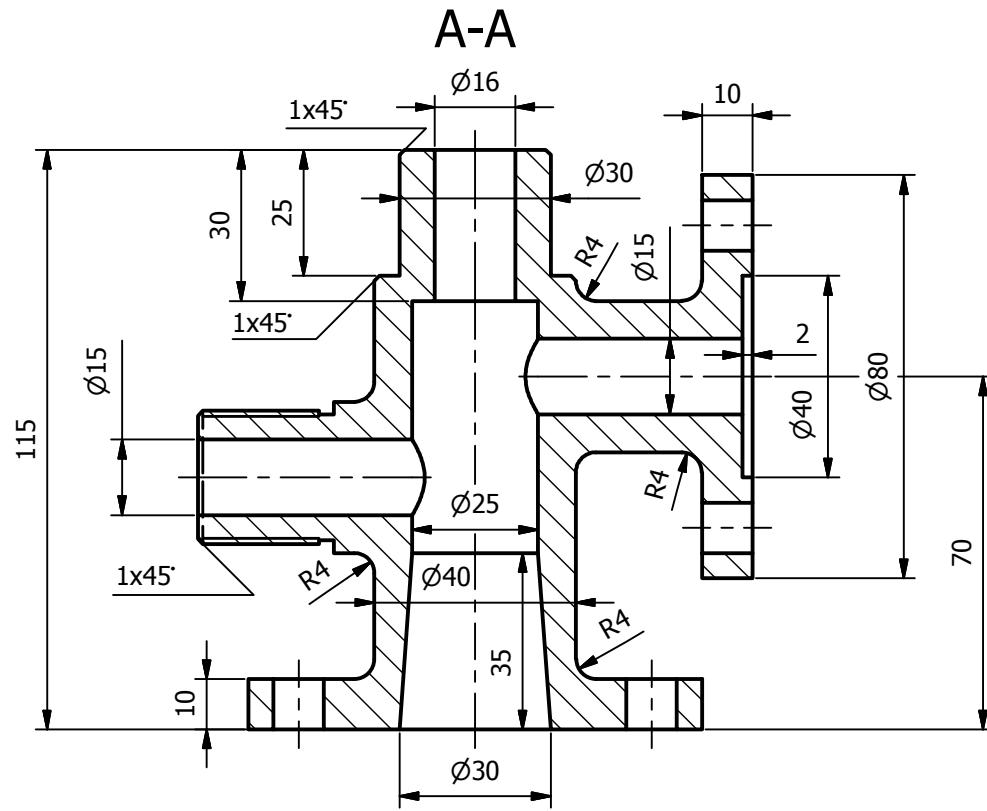

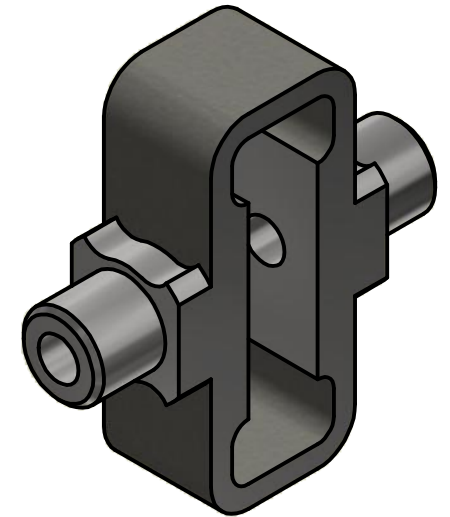
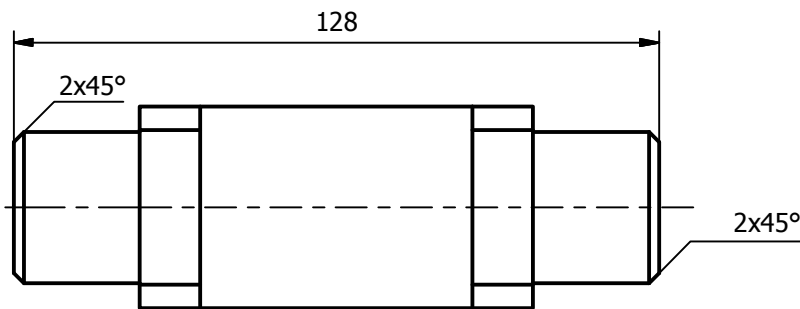
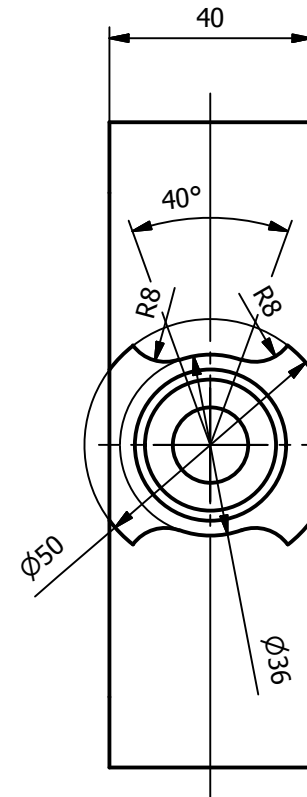
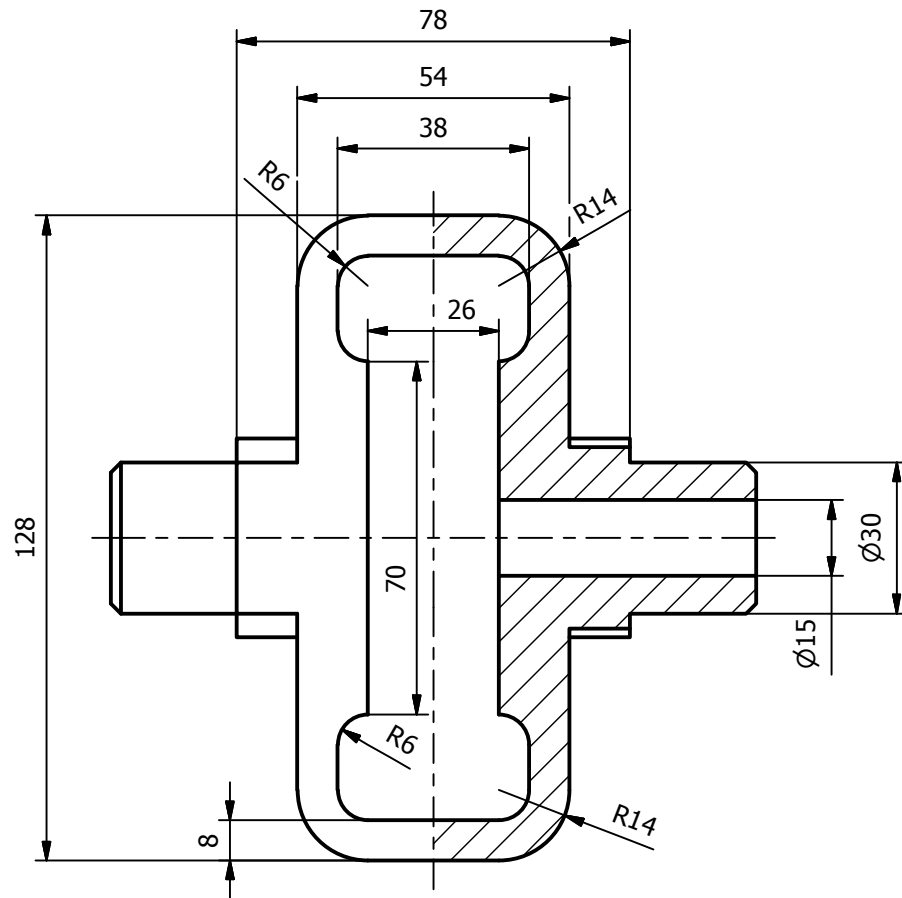

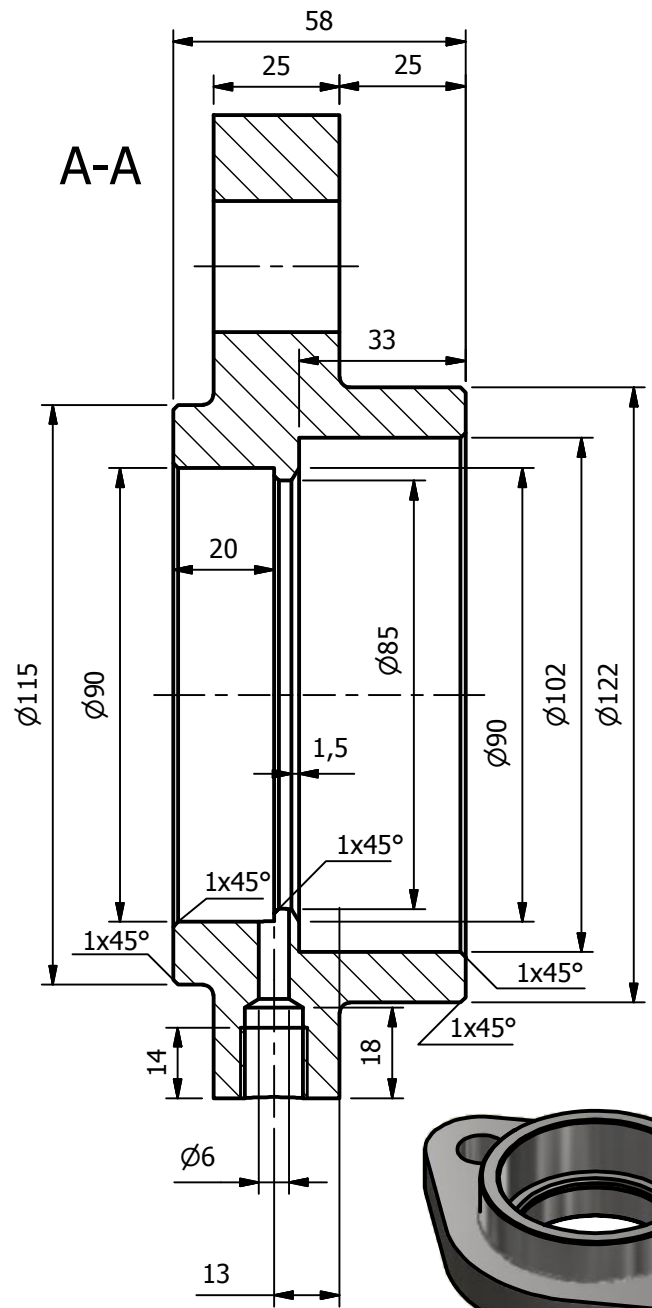
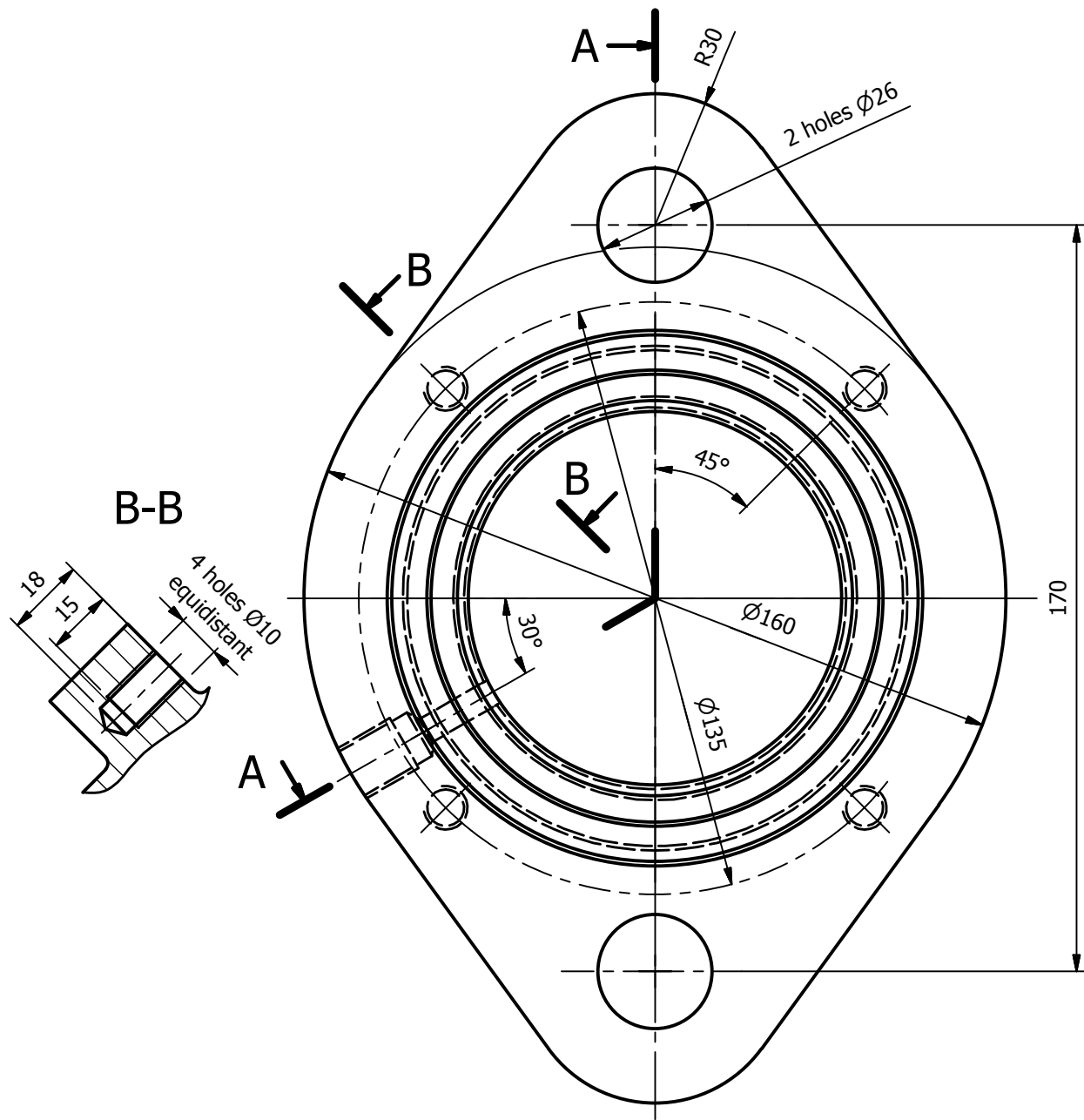

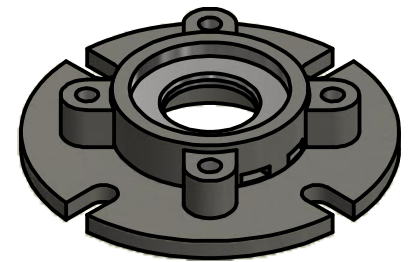
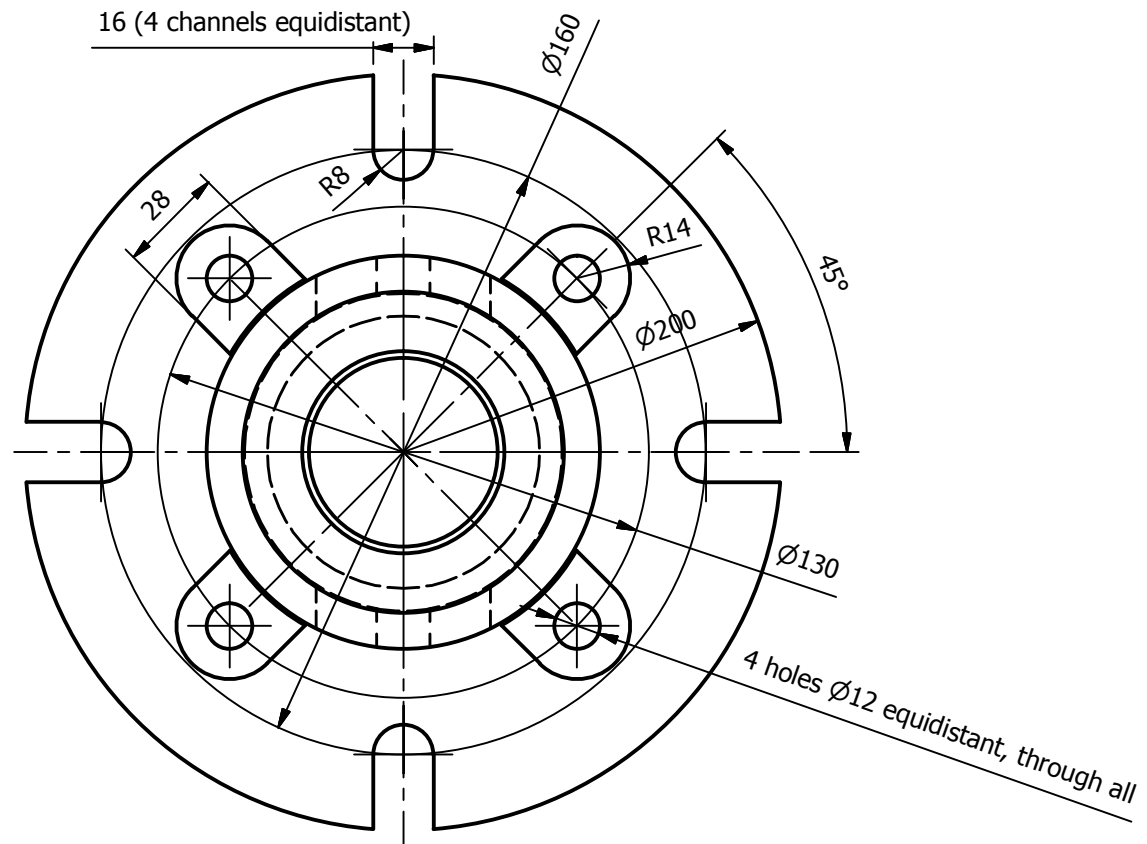
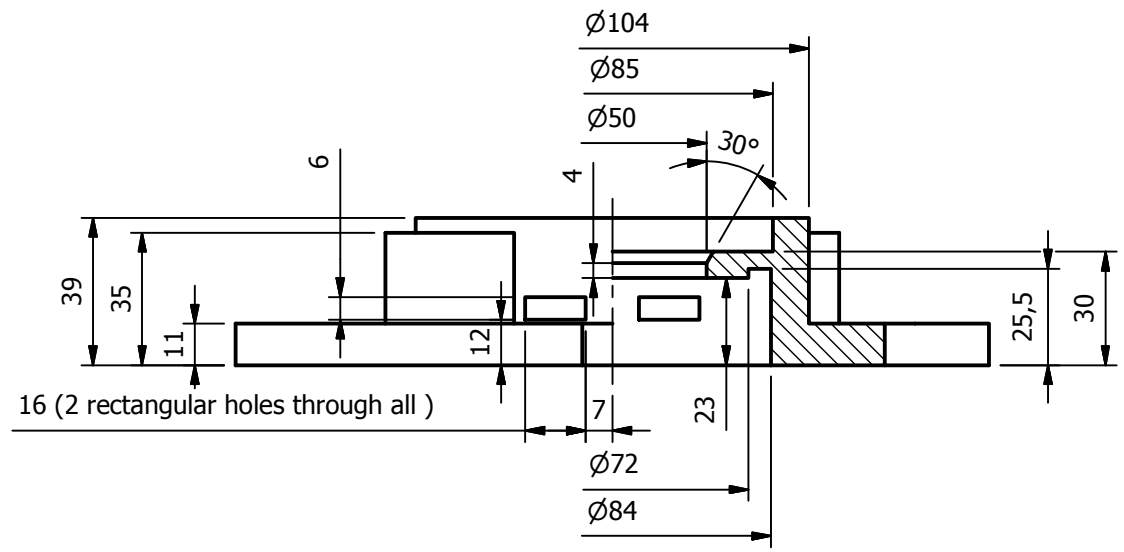

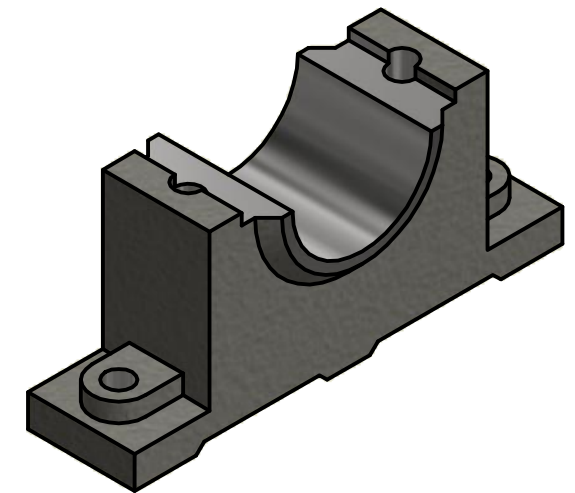
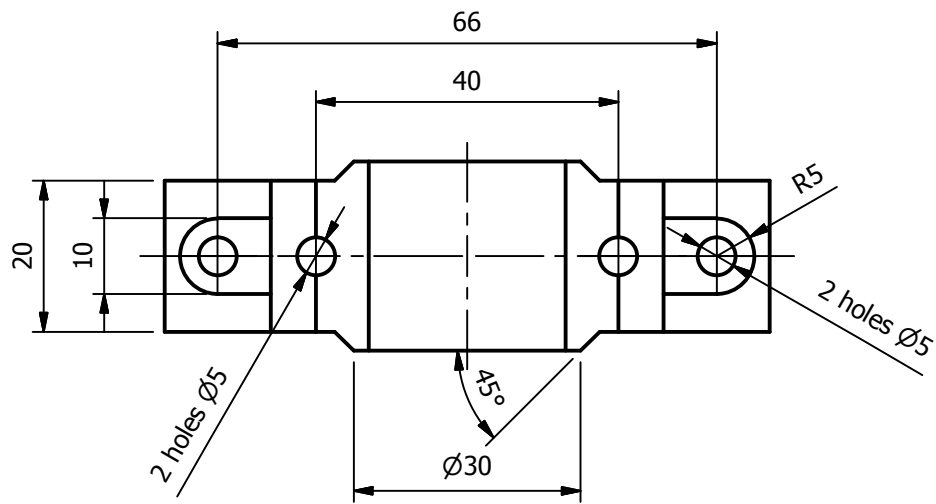
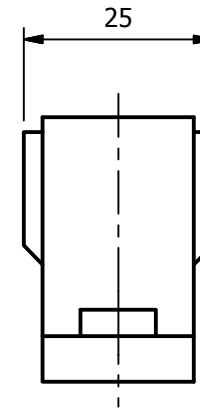
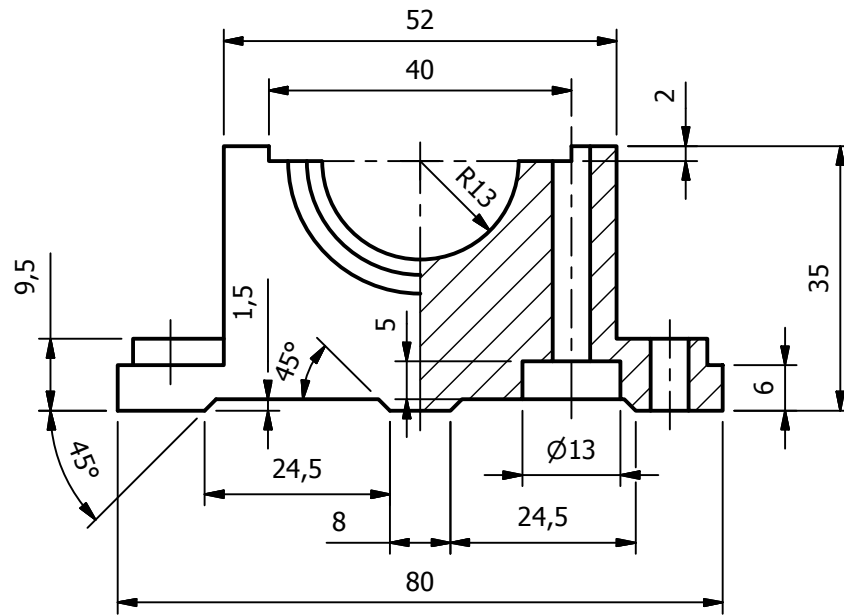

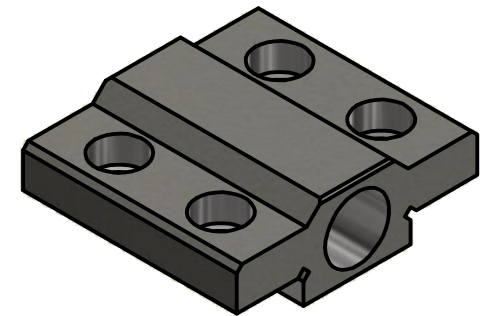
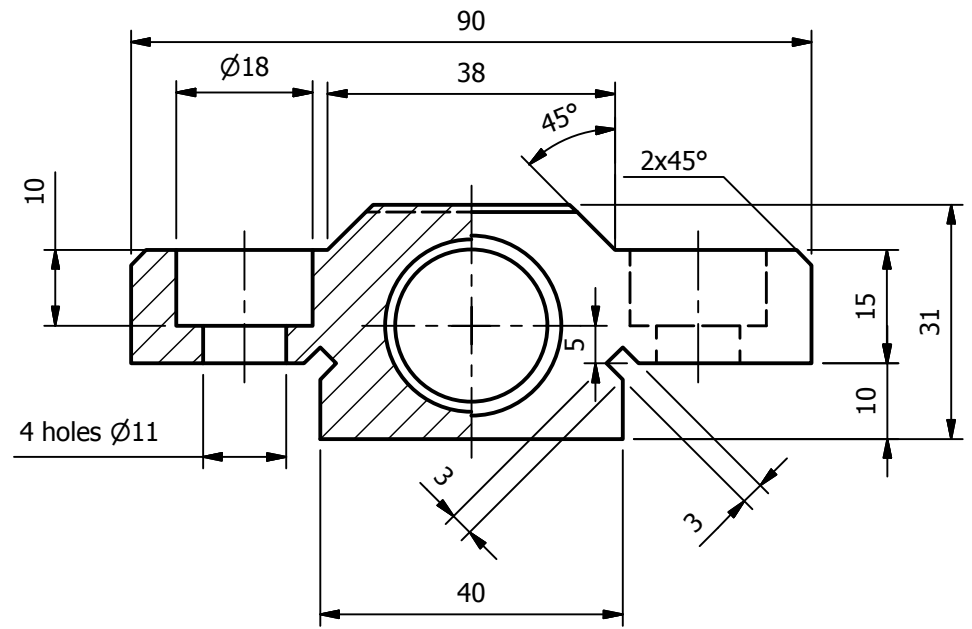
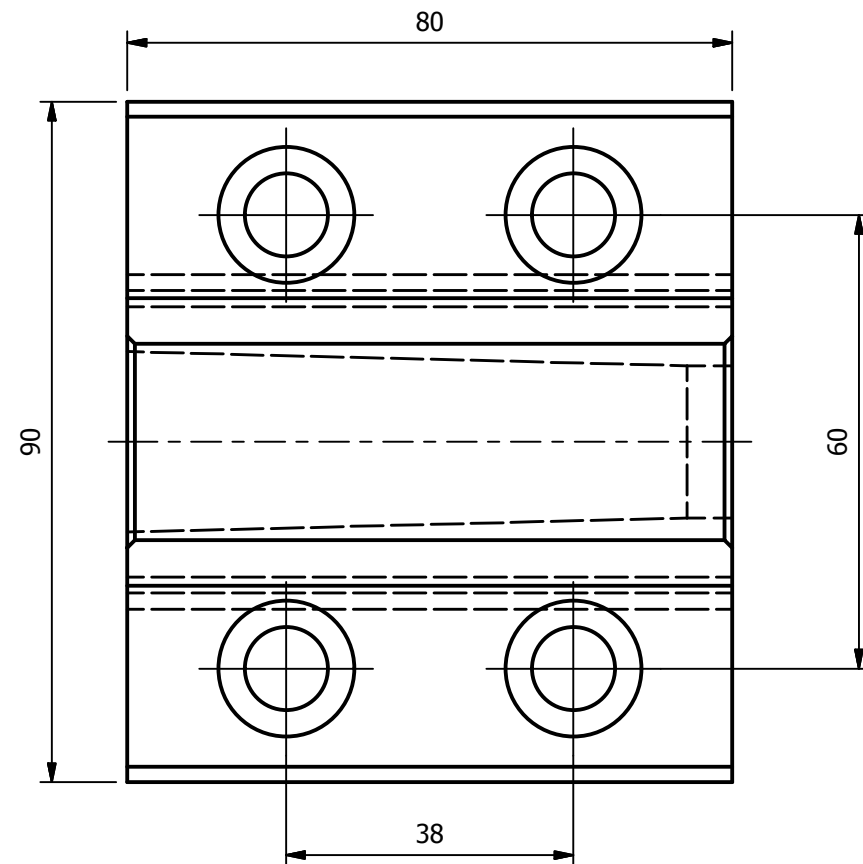
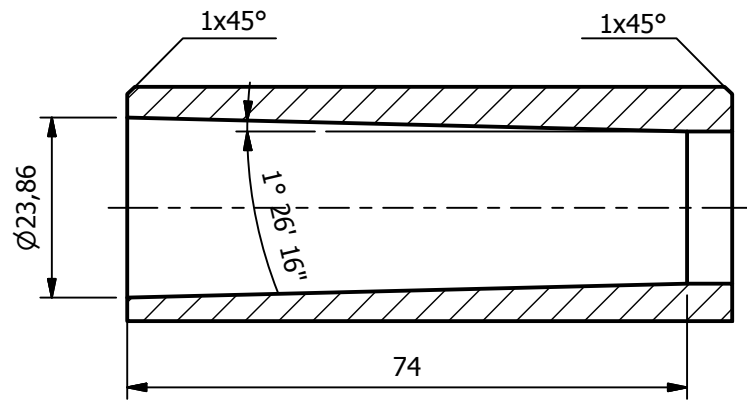

111738.015 mm³

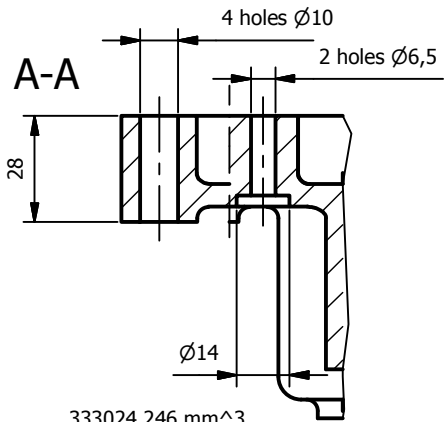
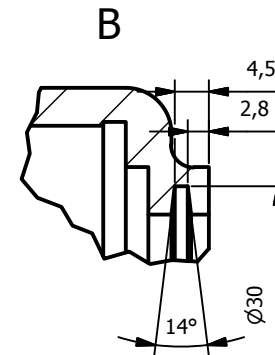
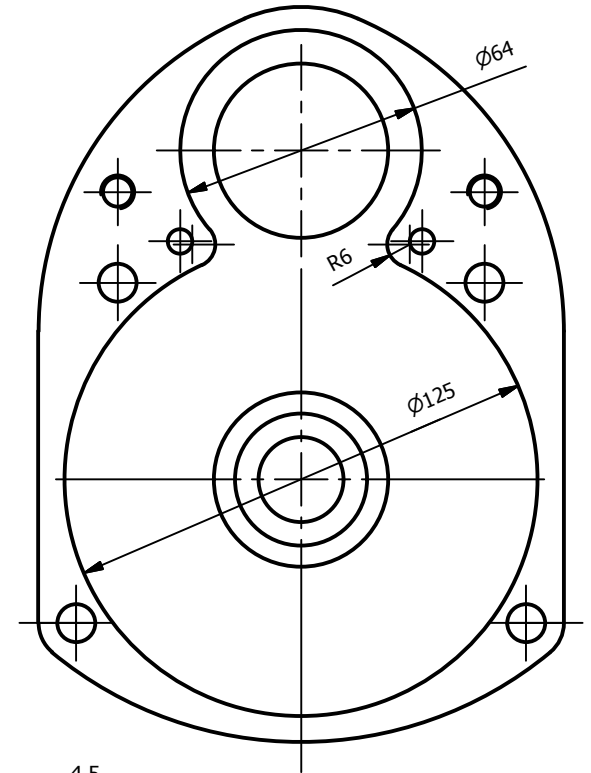
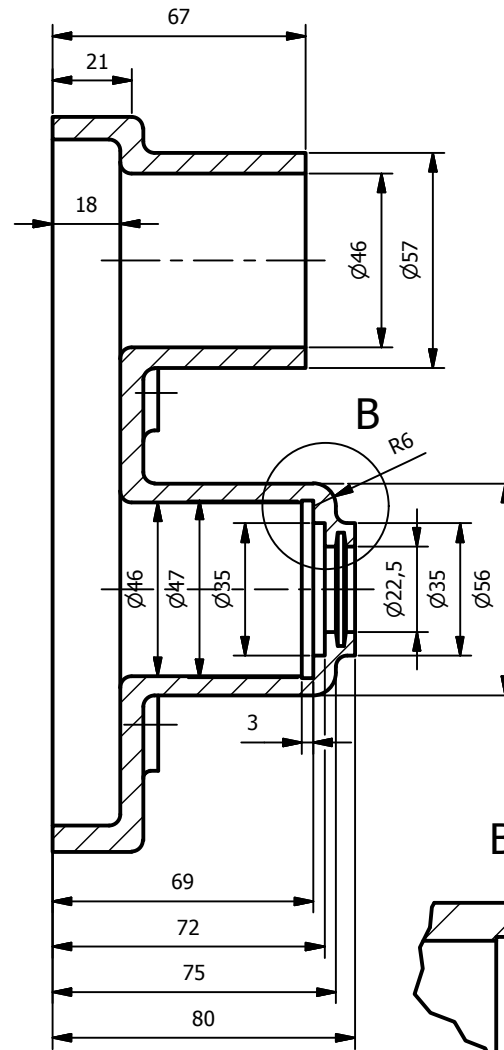
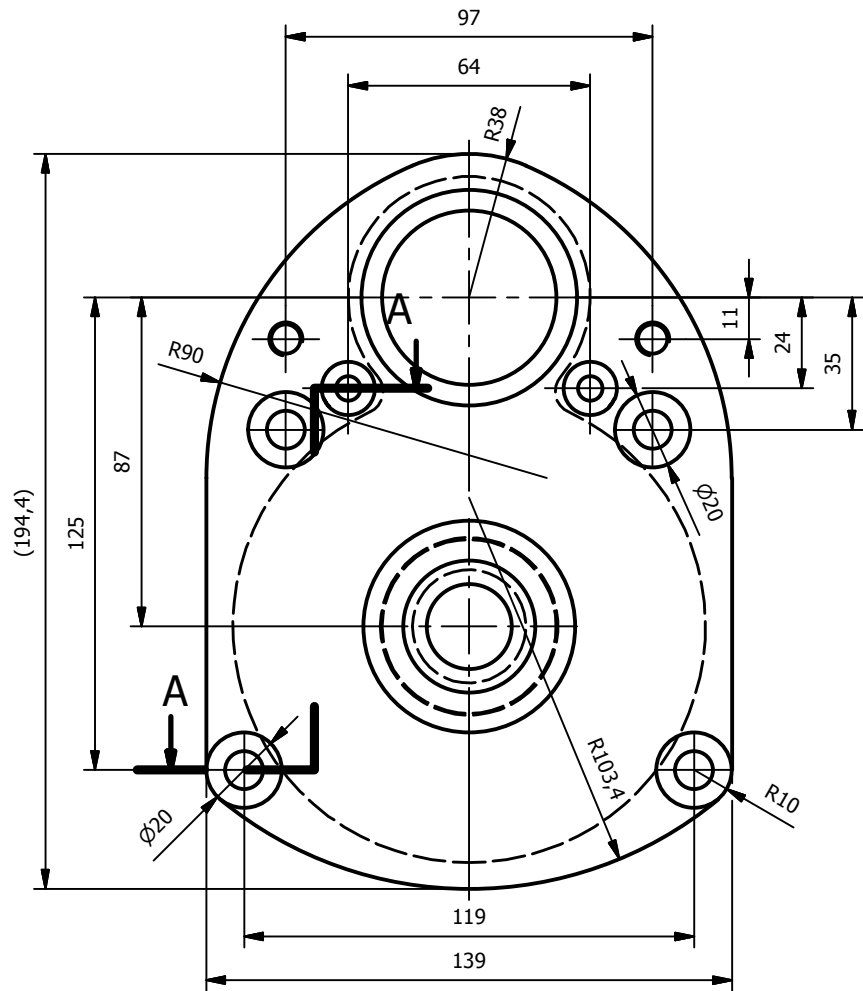

333024.246 mm^3

Note: The dimensions in paranthesis () are informal only



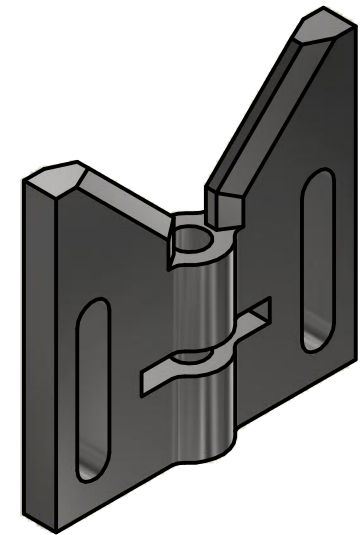
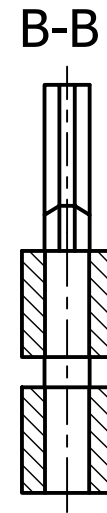
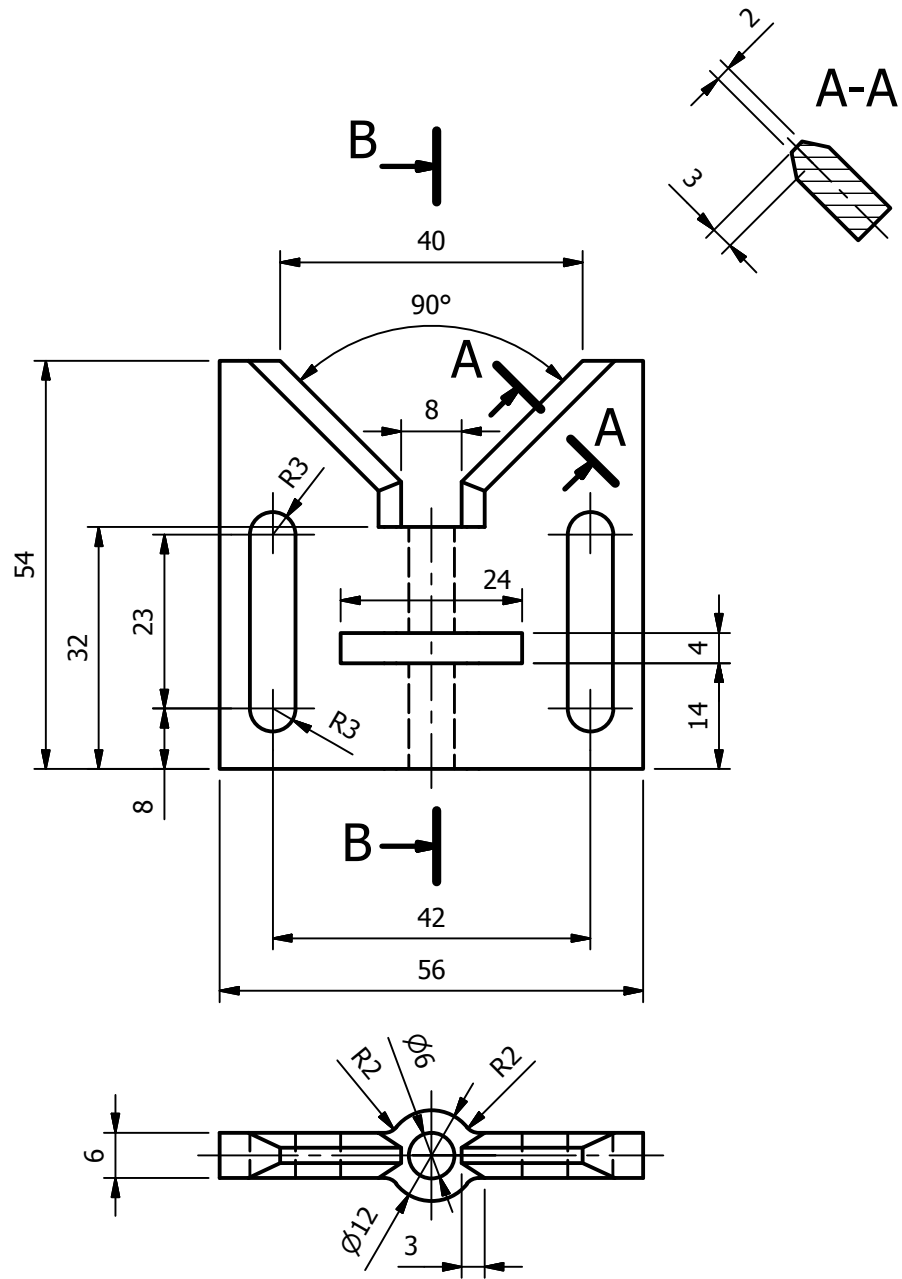

13098.750 mm³

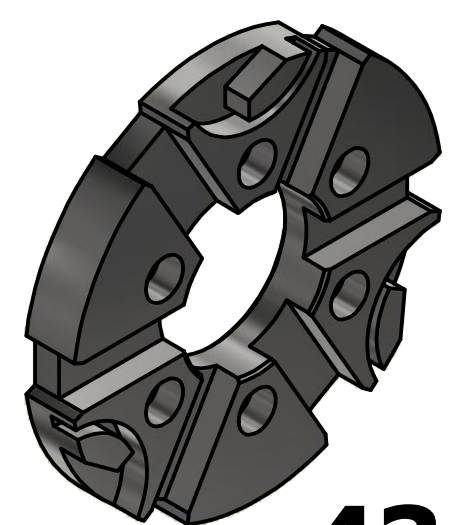
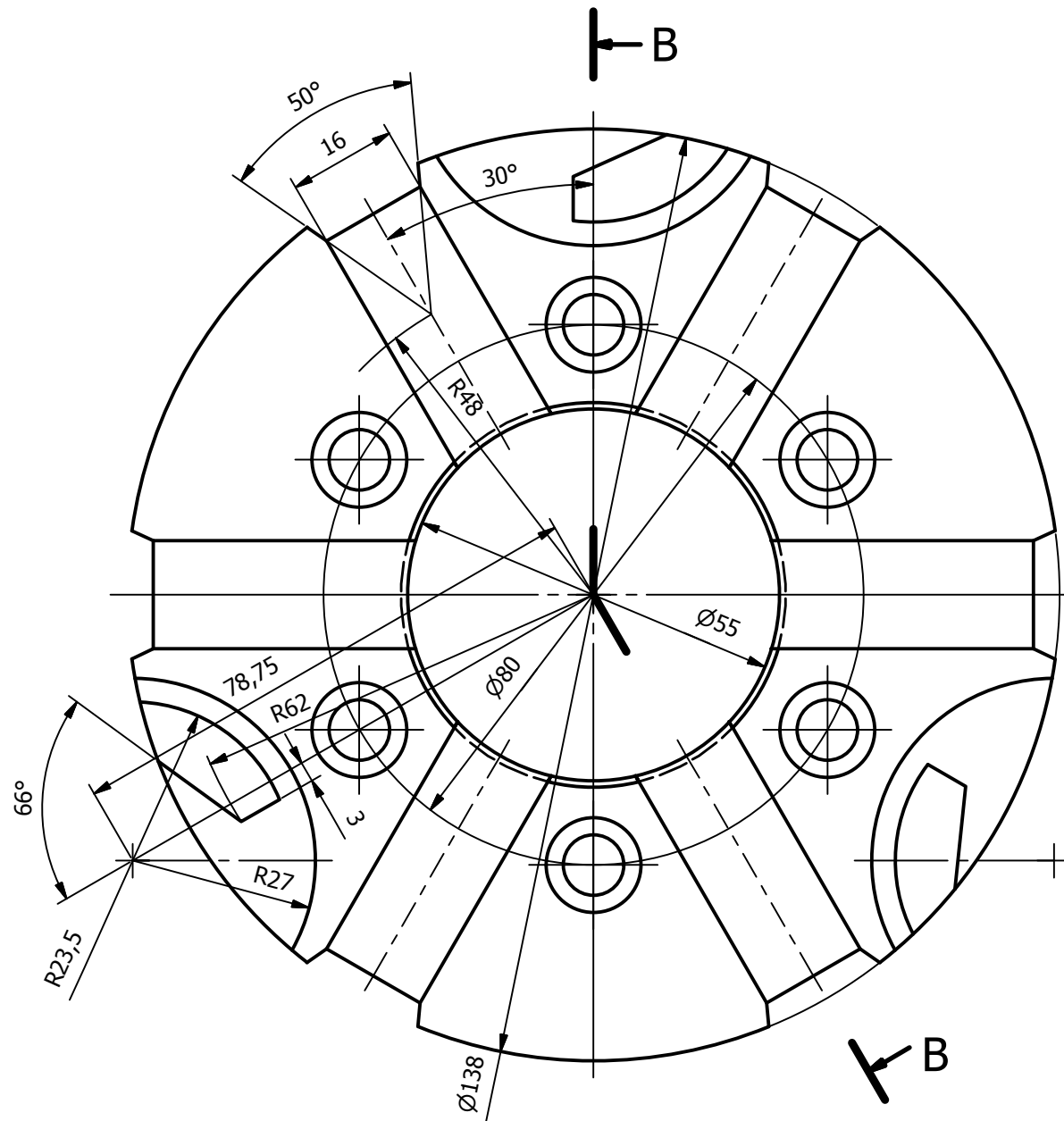
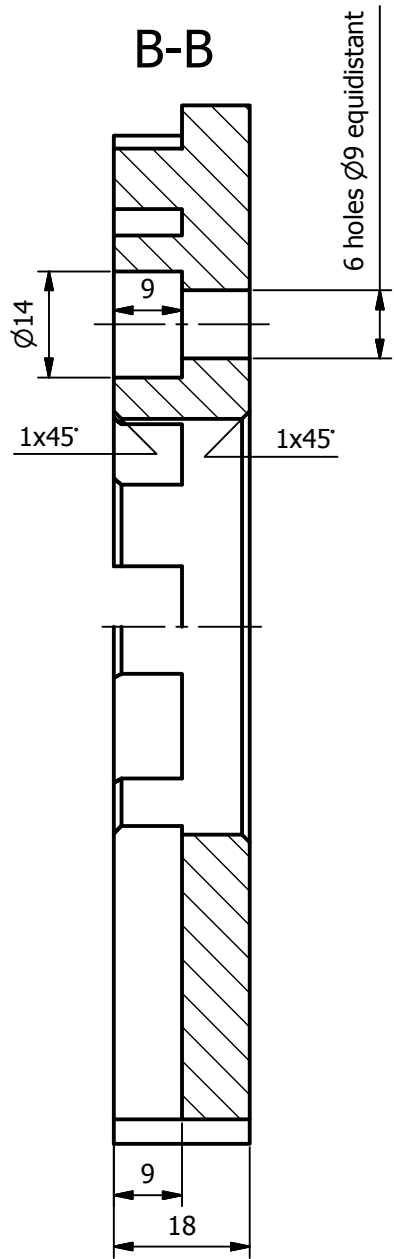

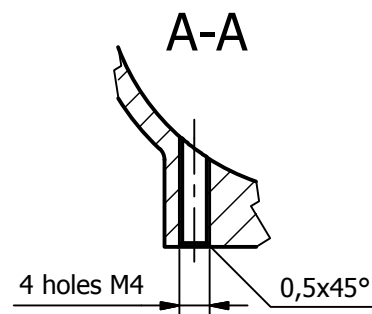
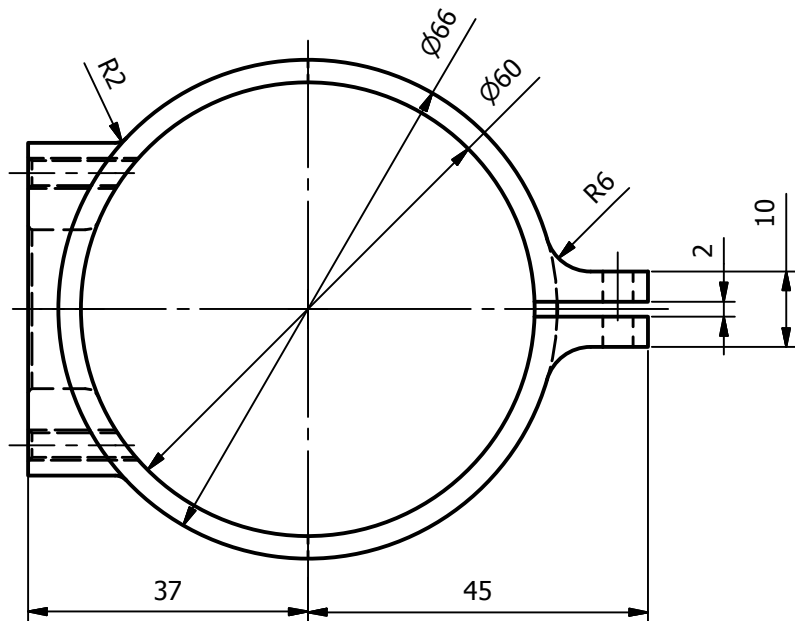
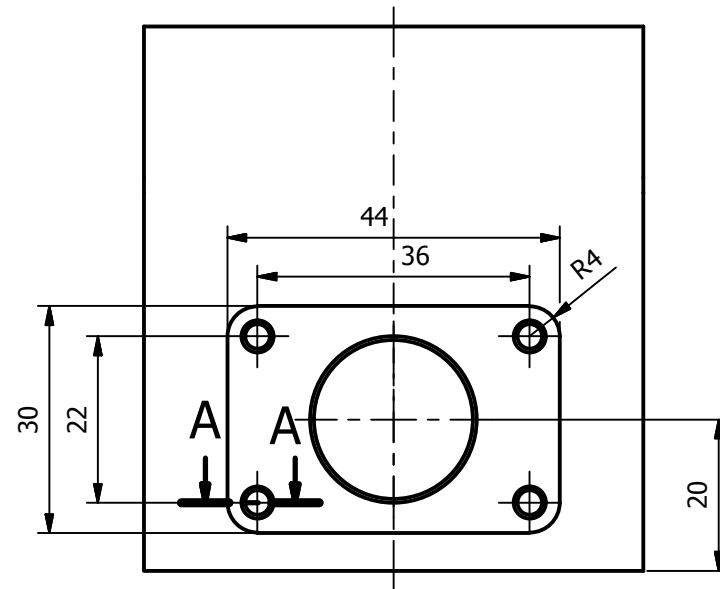
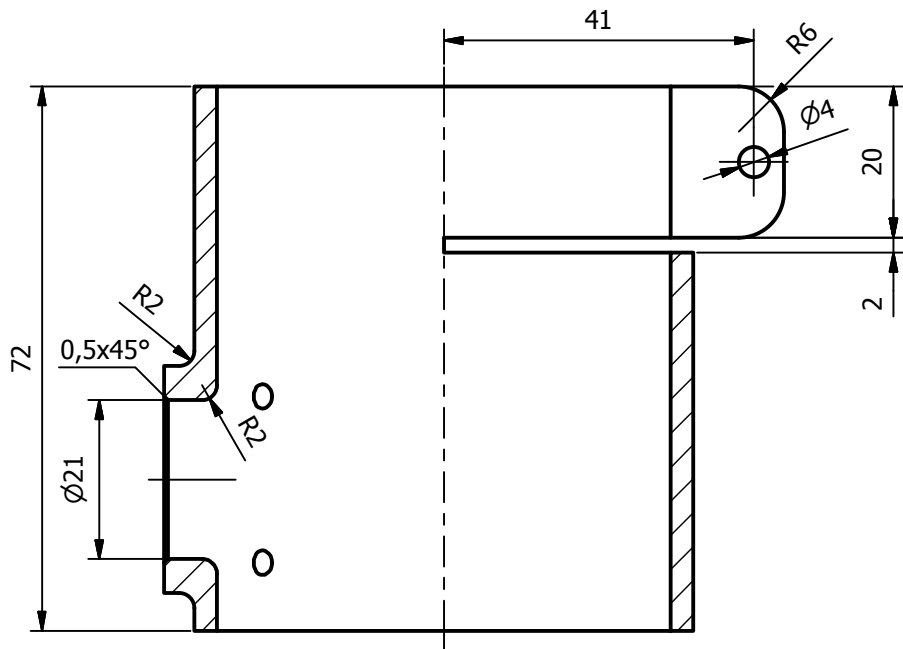

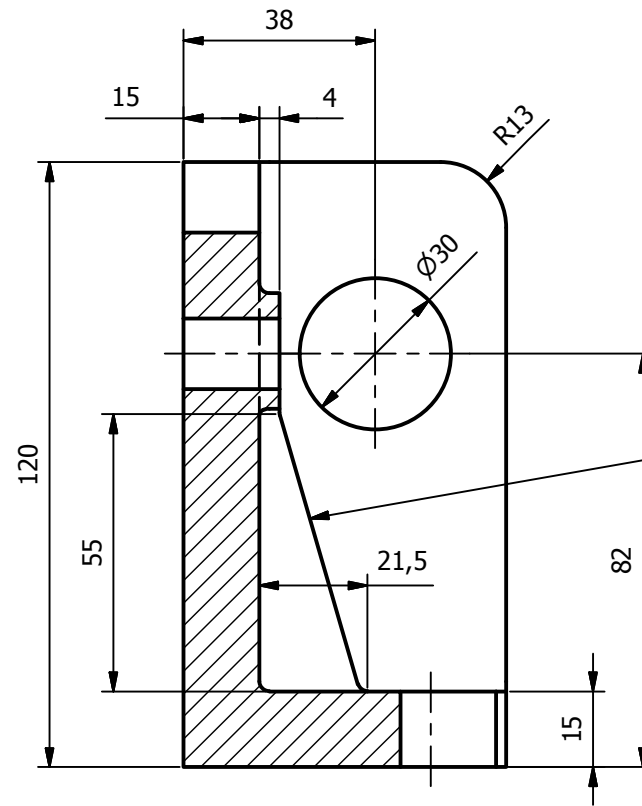
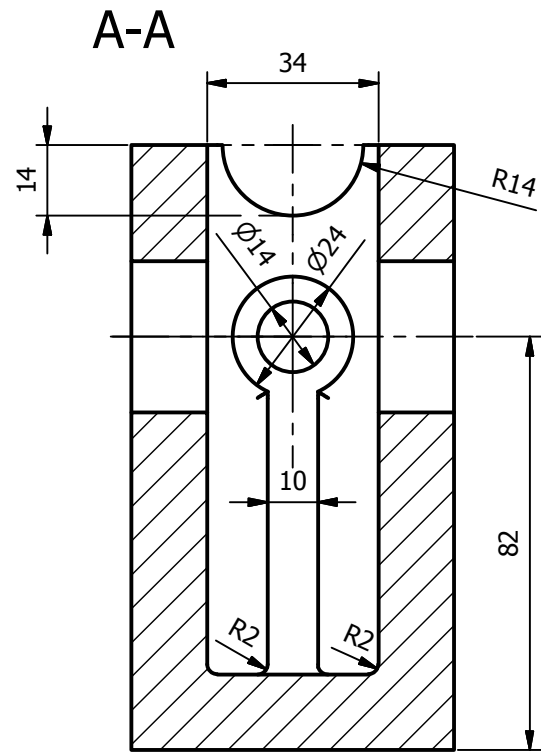

By standard, when a rib is sectioned in its mid-plane the hatch is void

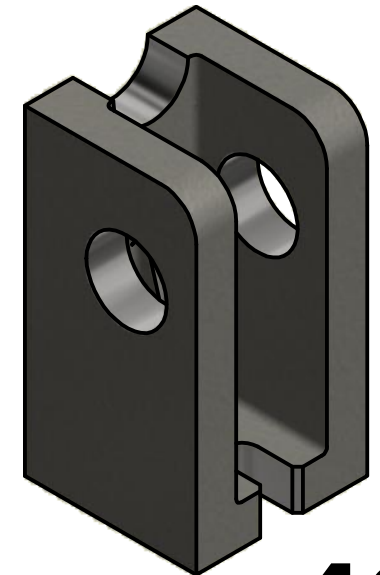
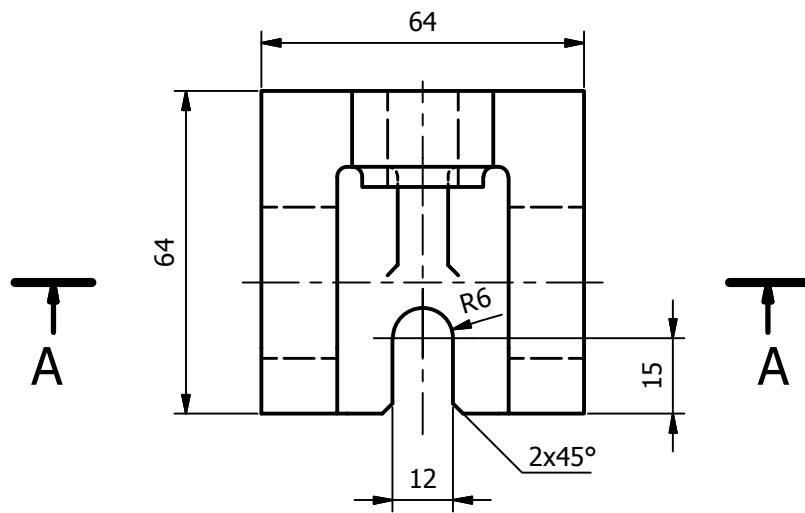

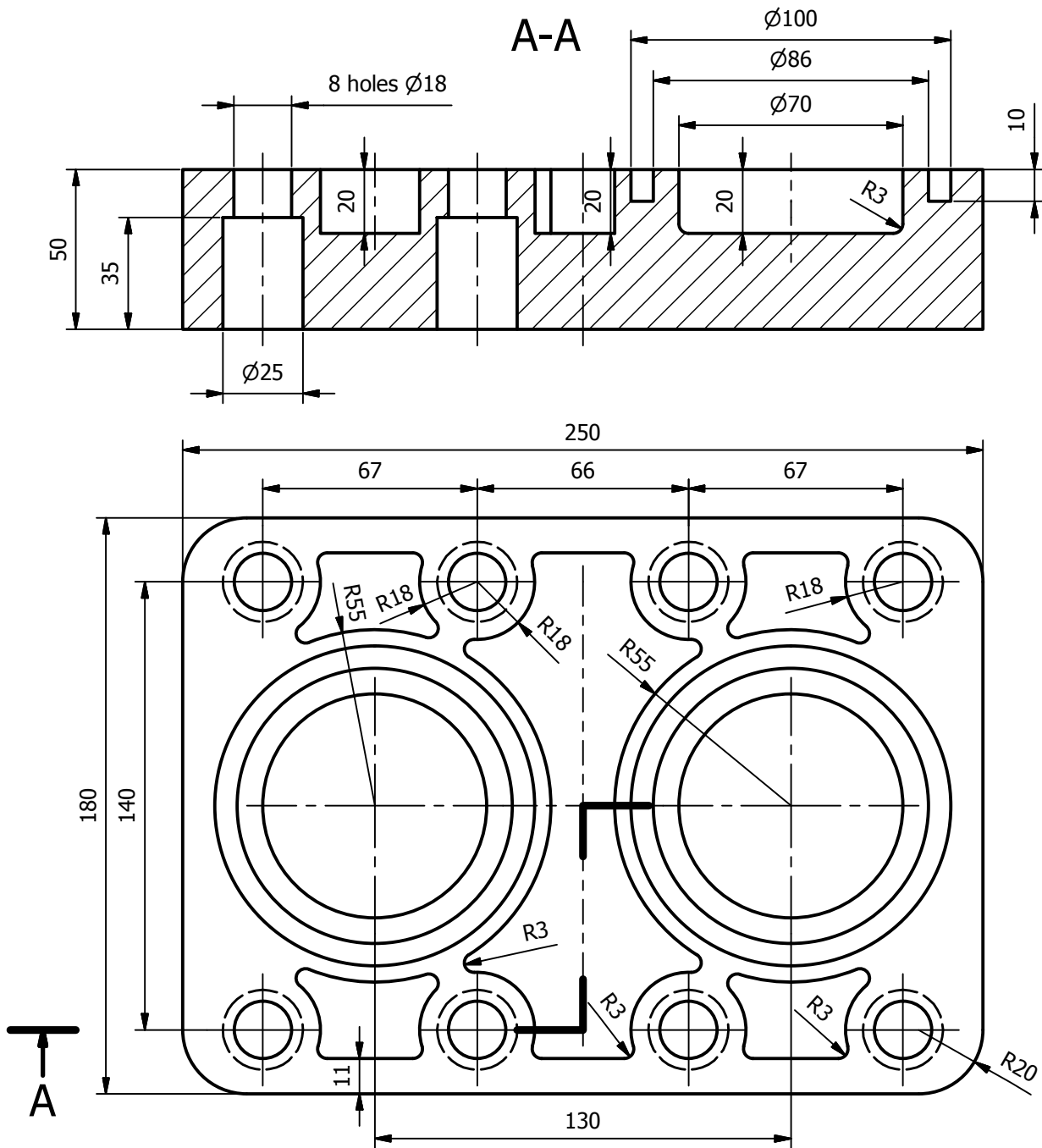

1680918.203 mm³

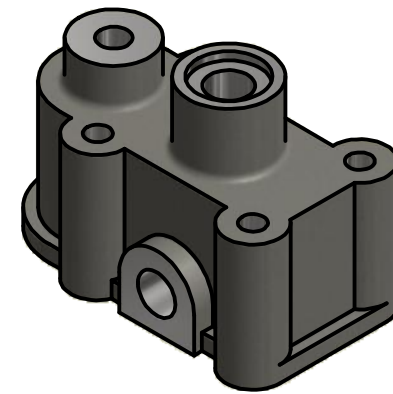
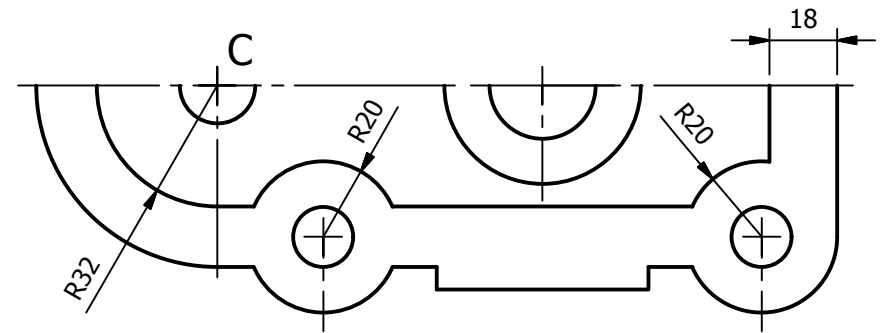
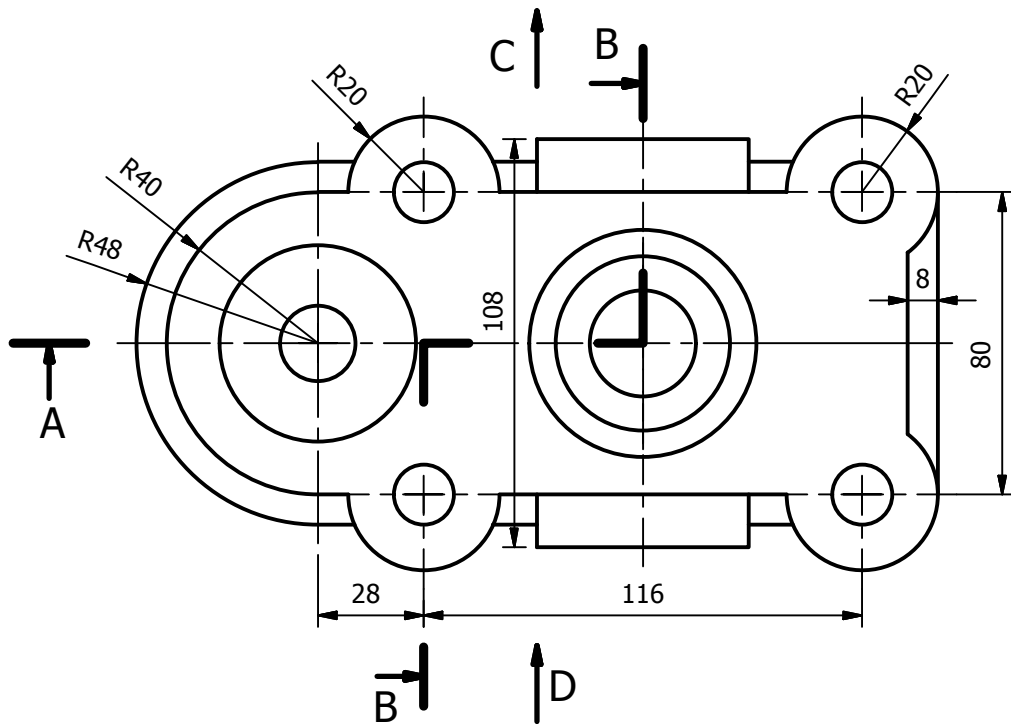
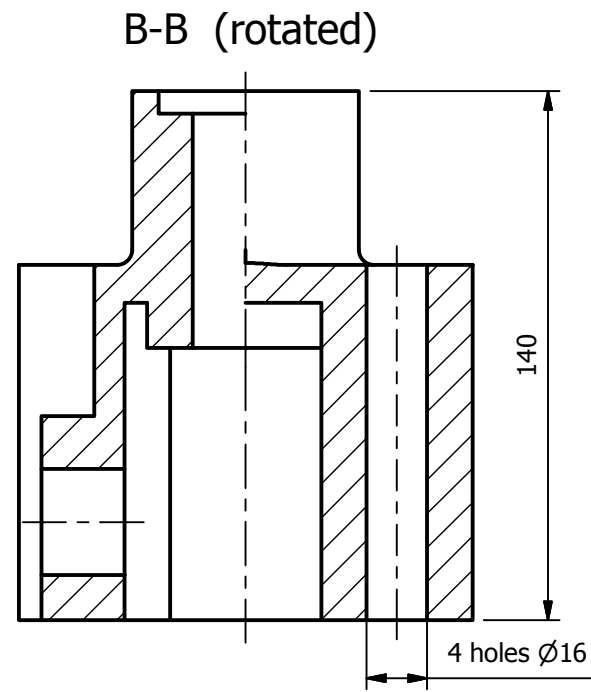
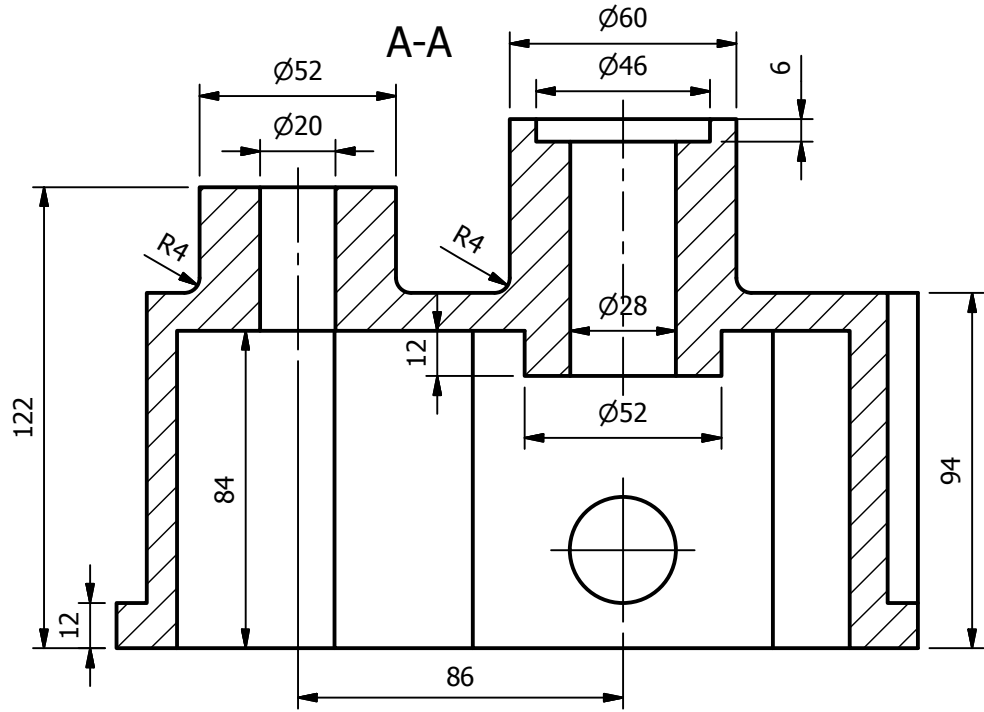

979569.527 mm³

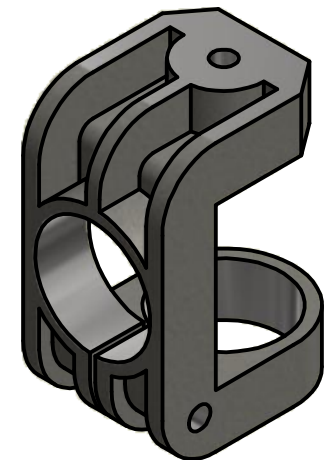
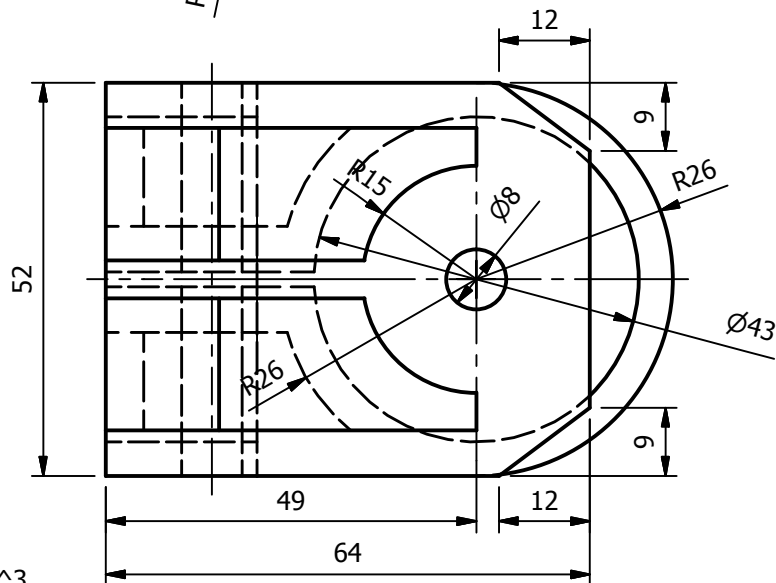
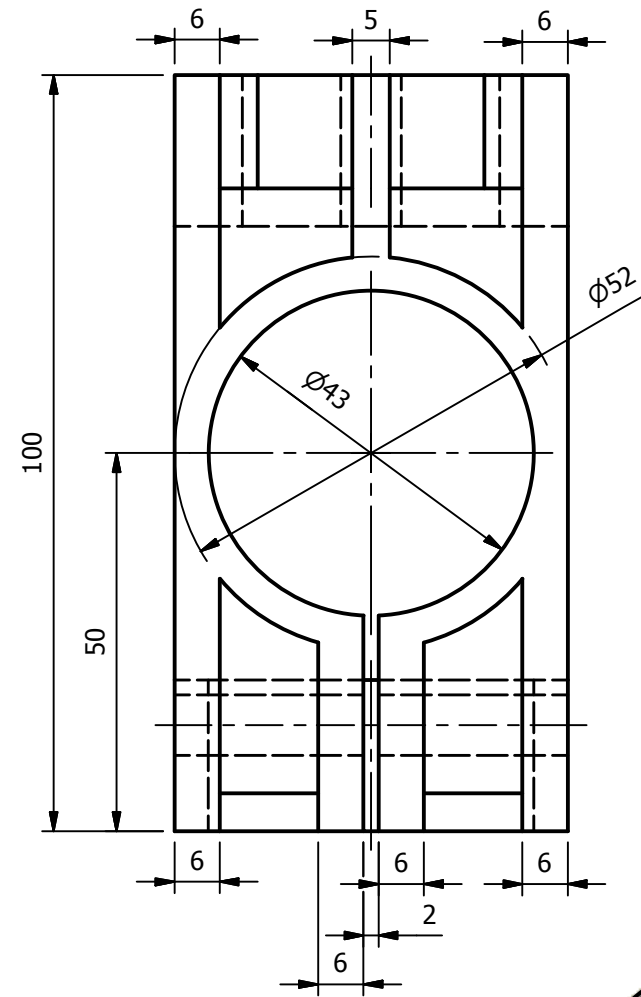
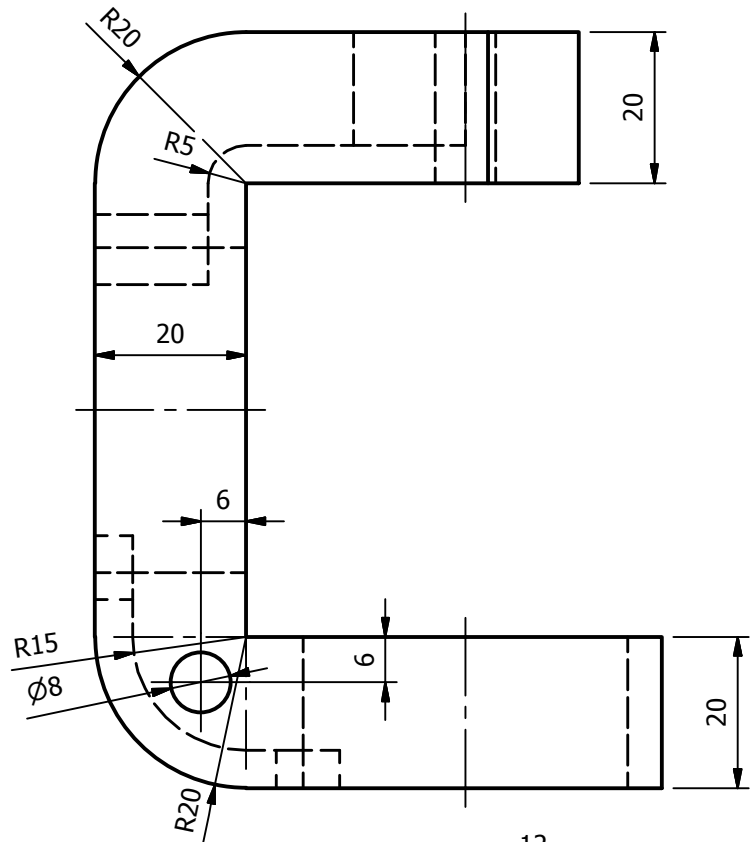

96445.594 mm³

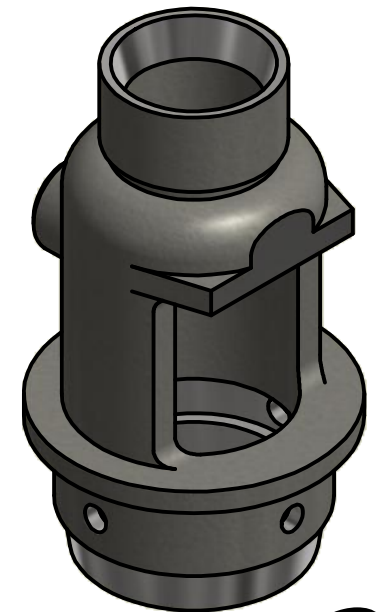
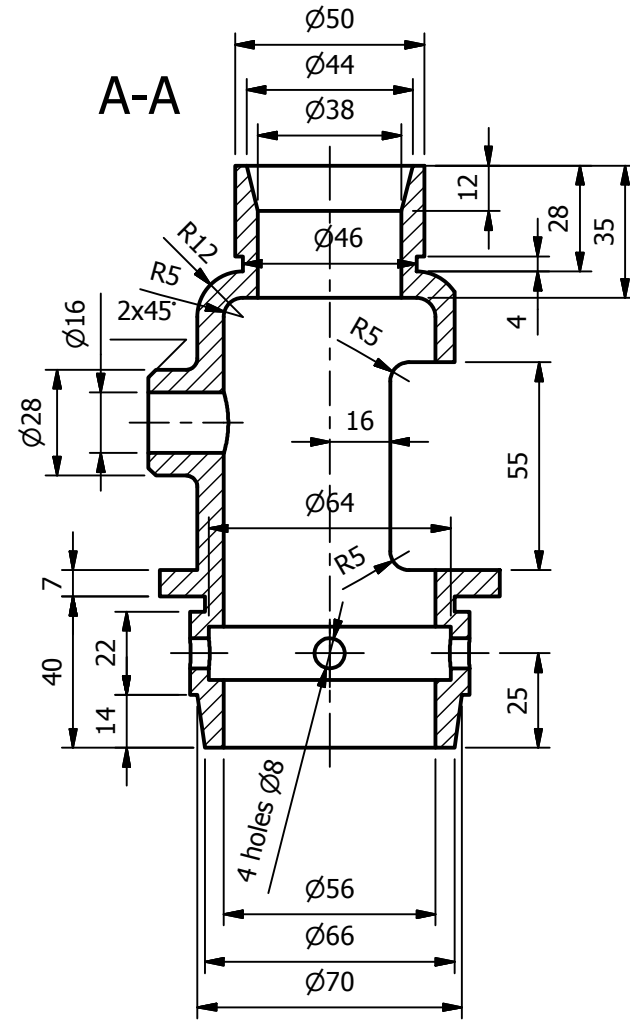
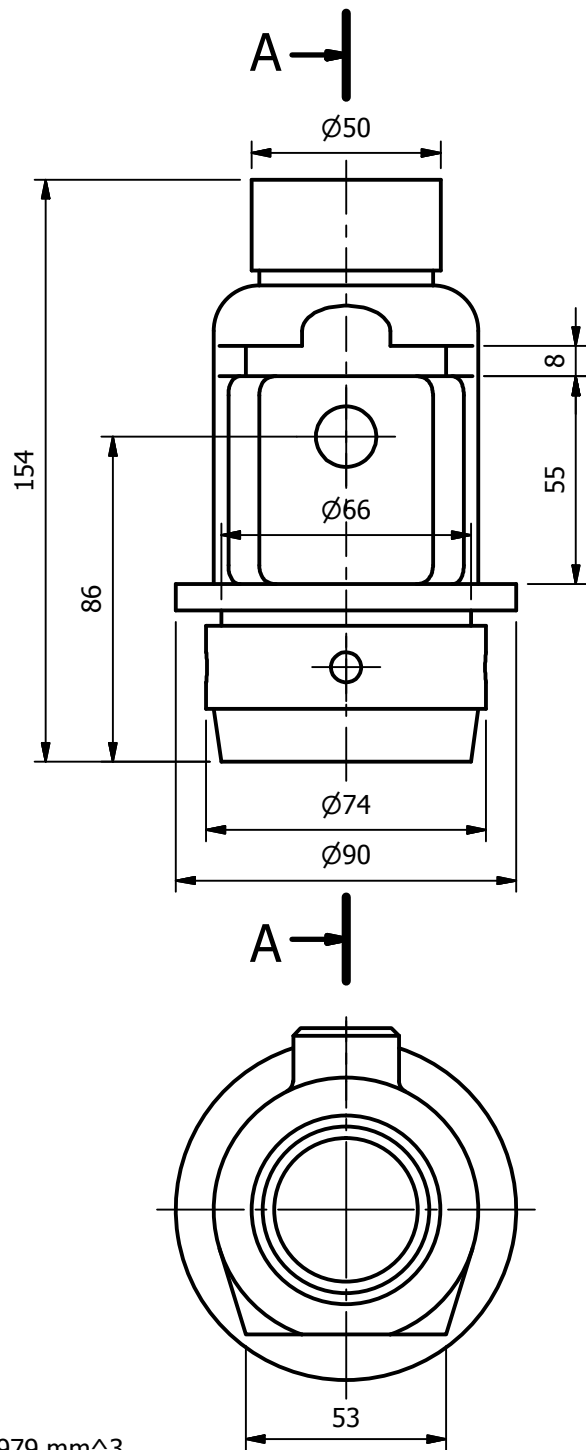

189717.979 mm³

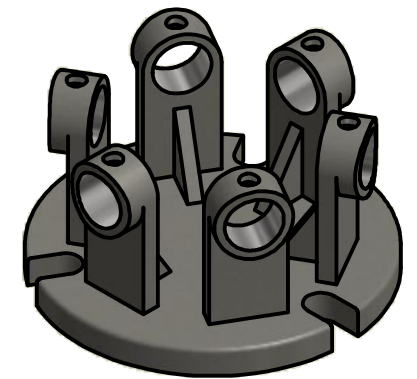
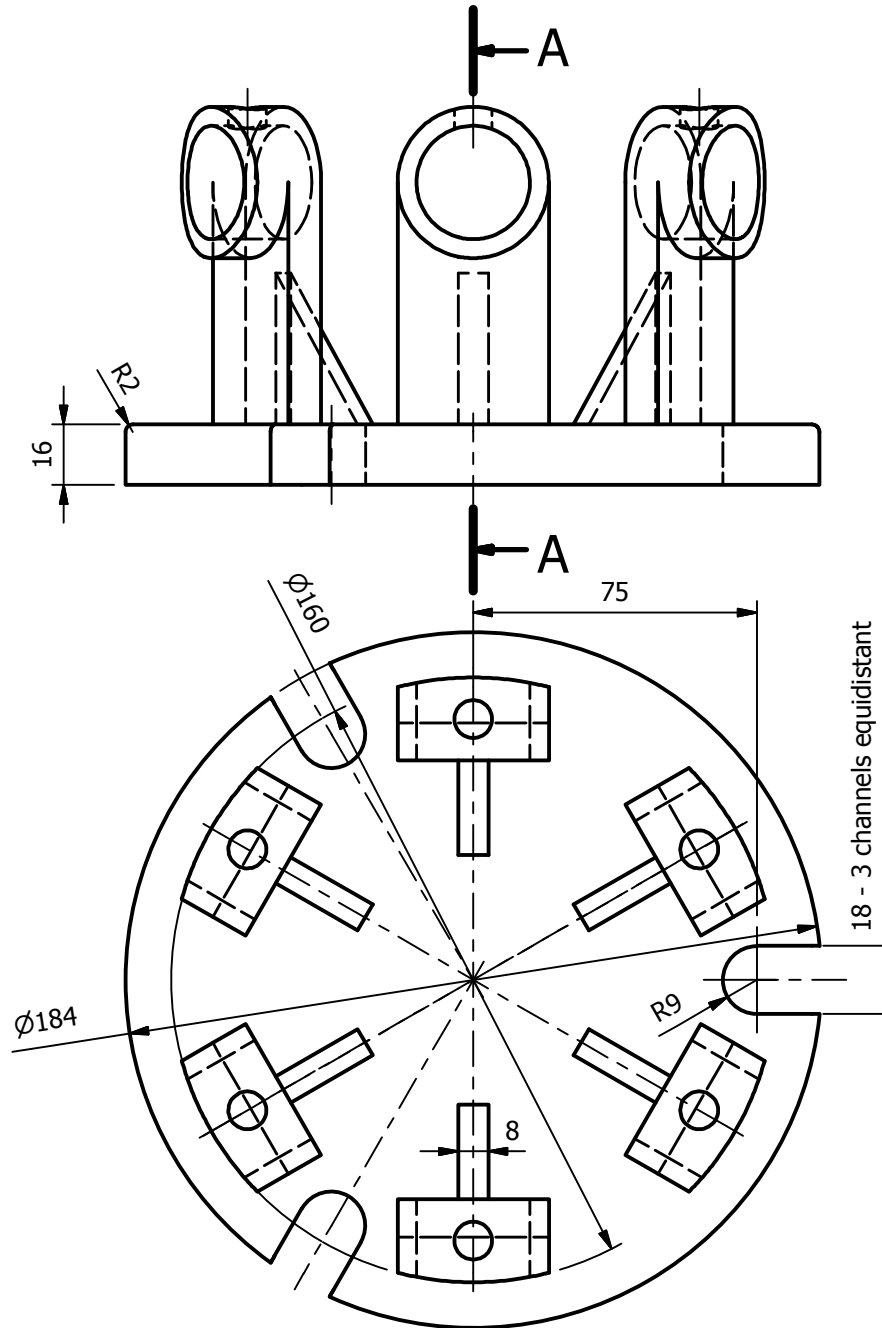
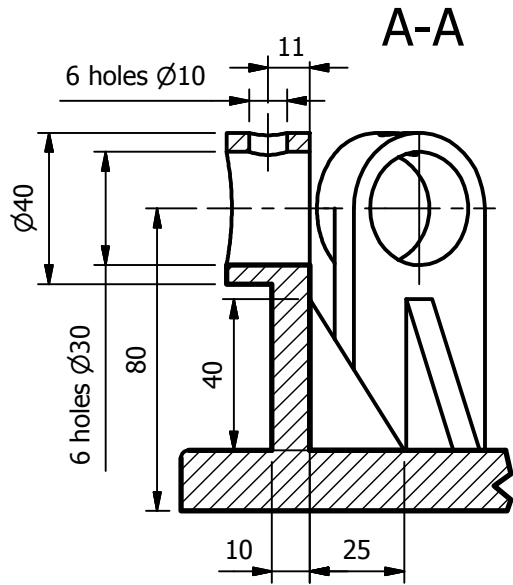

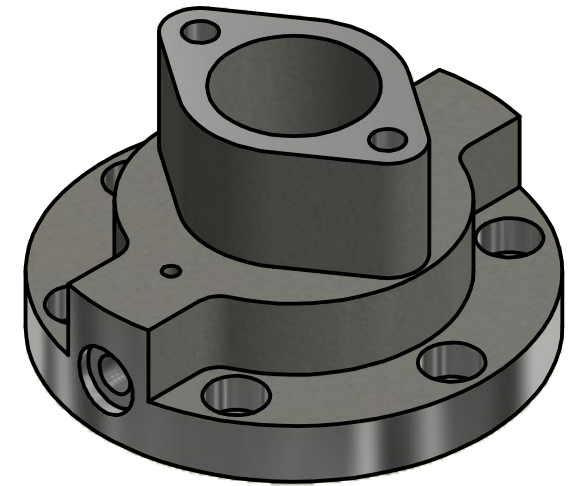
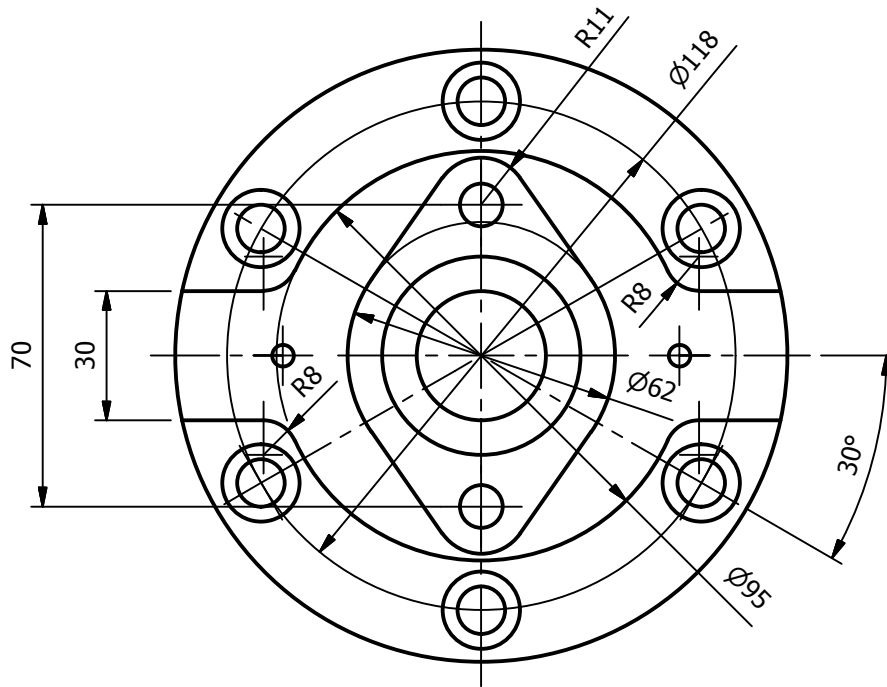
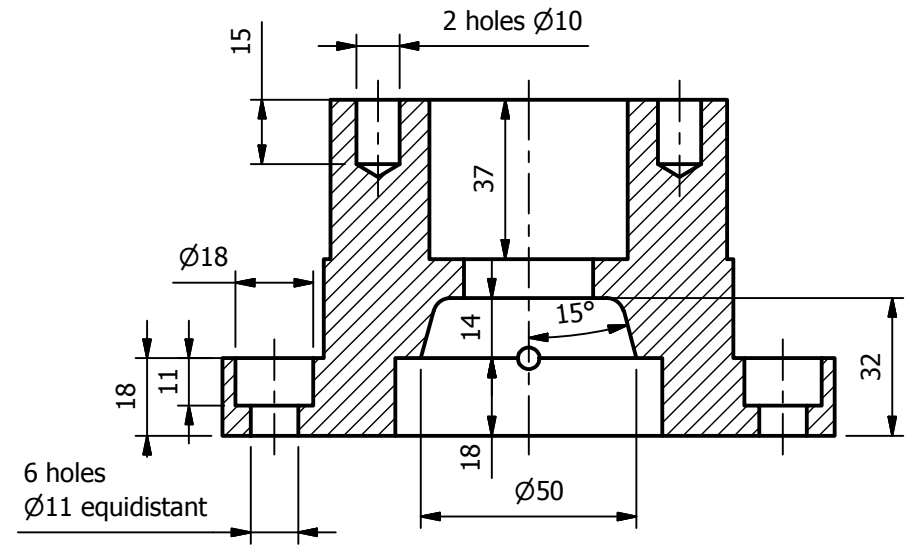
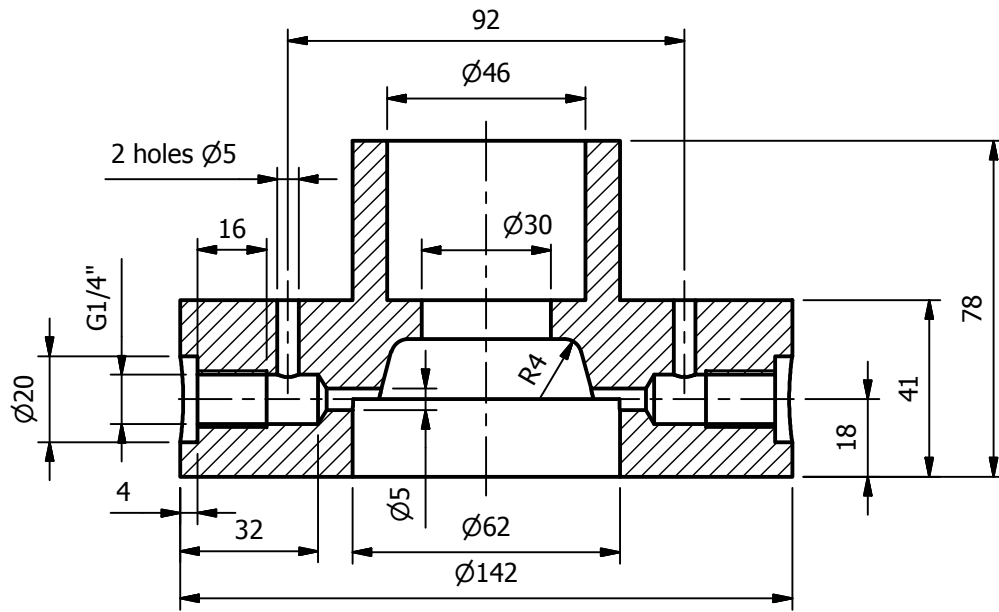

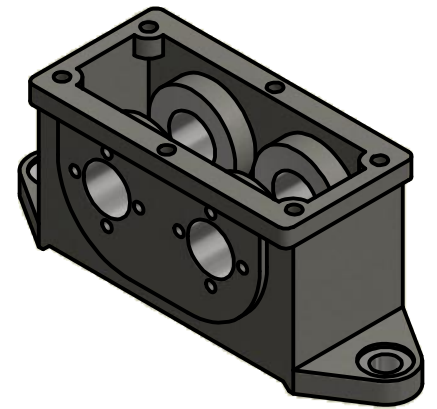
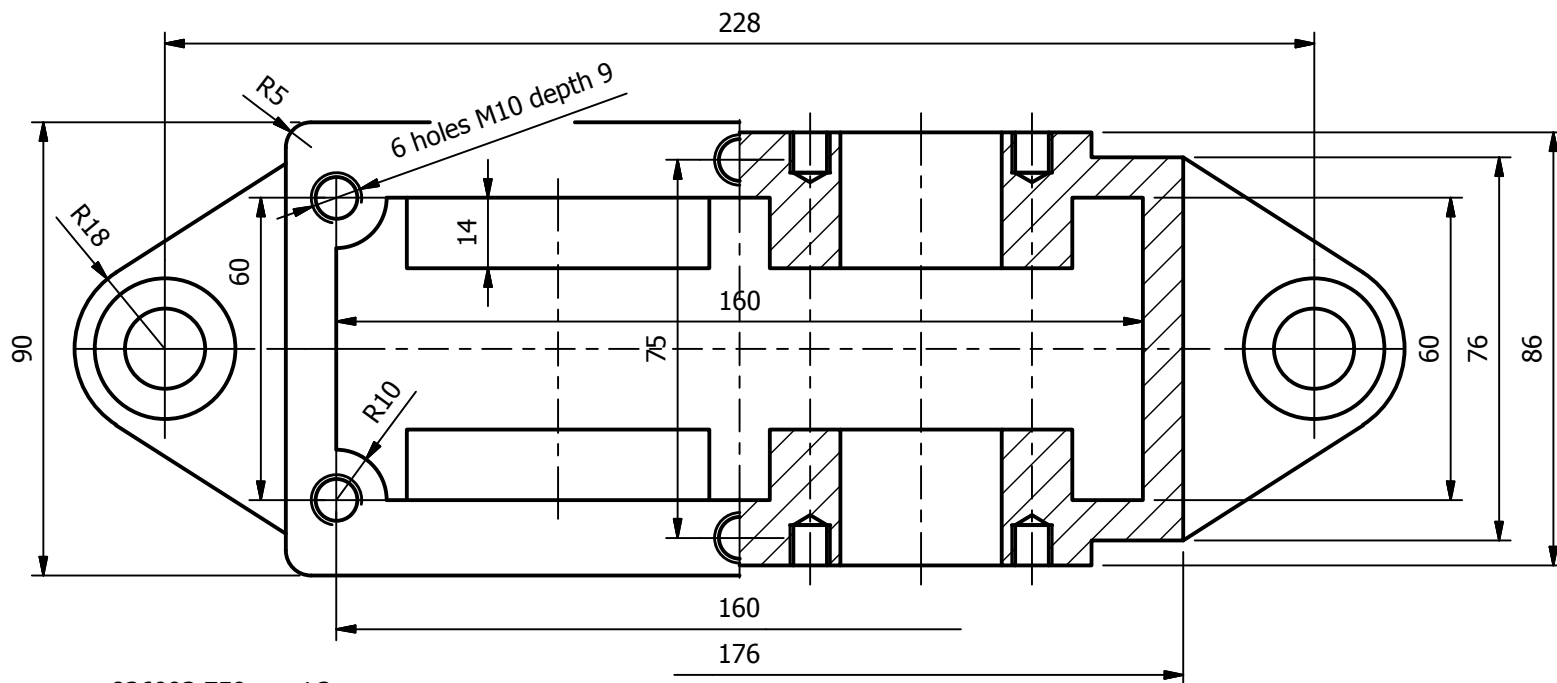
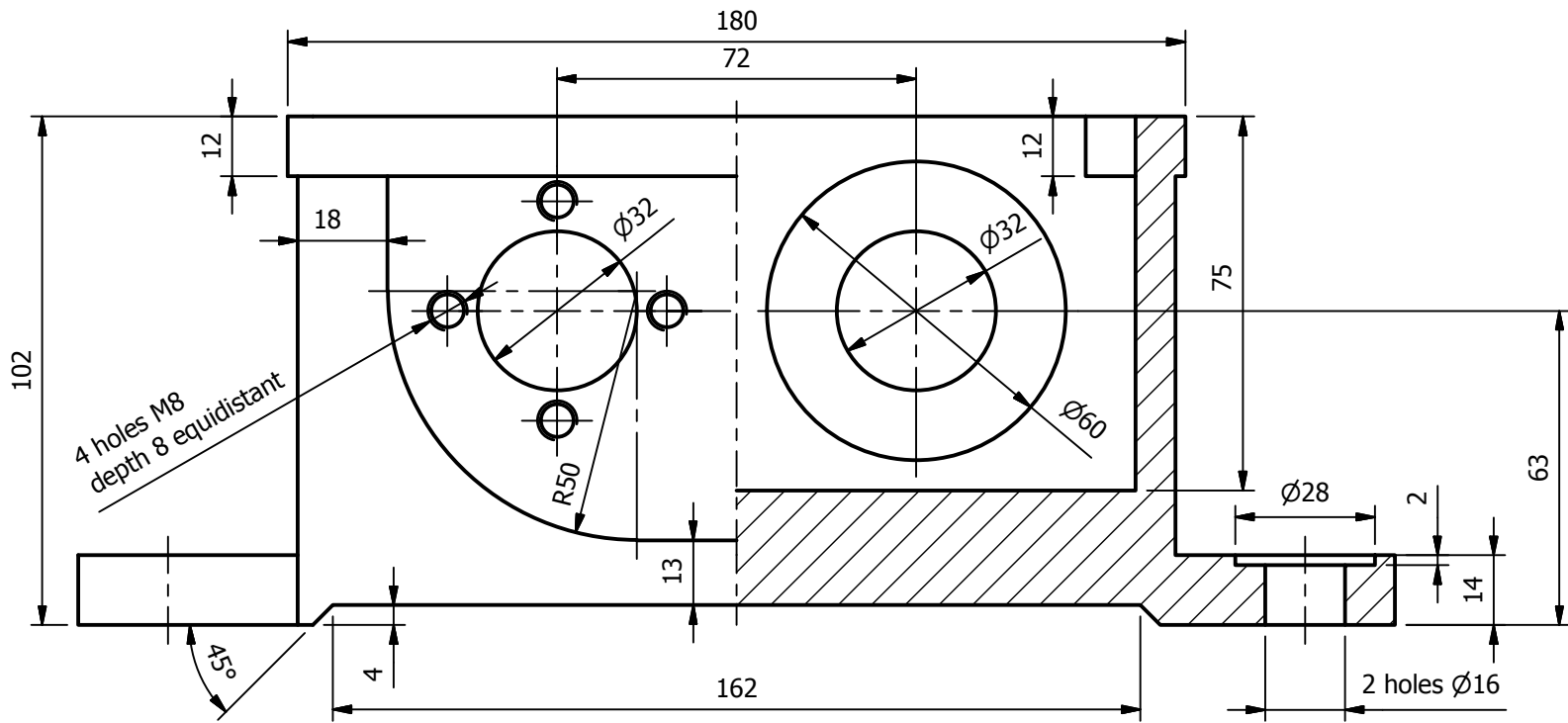

836993.759 mm³

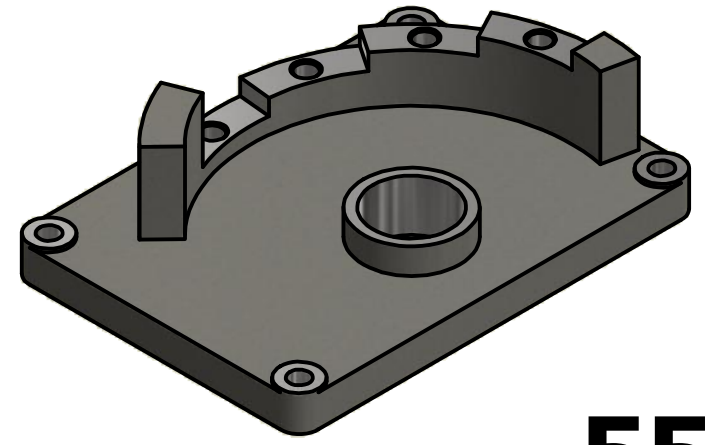
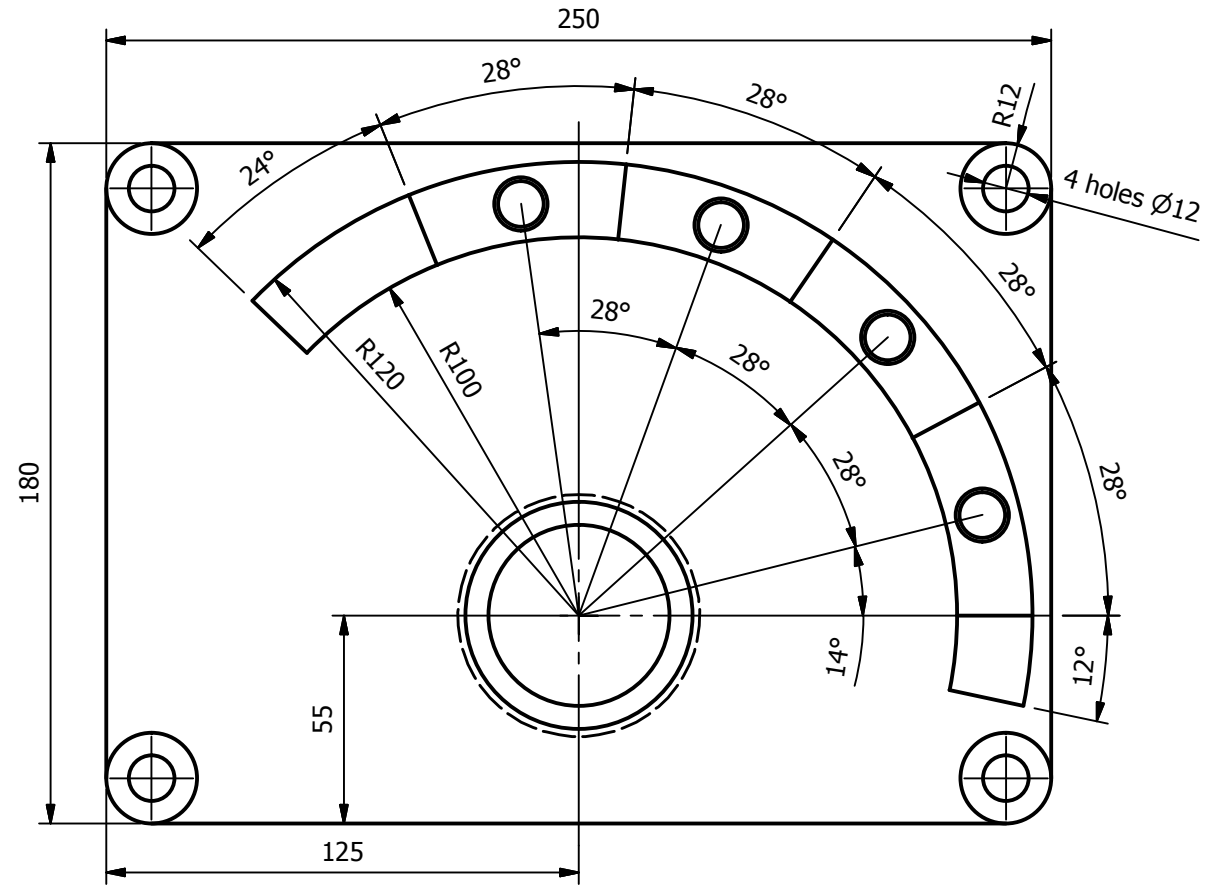
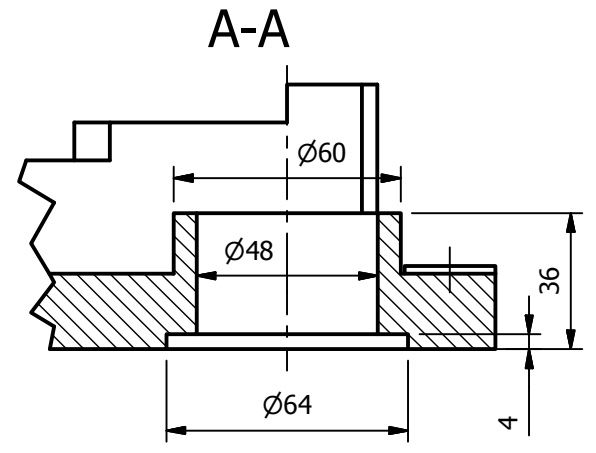
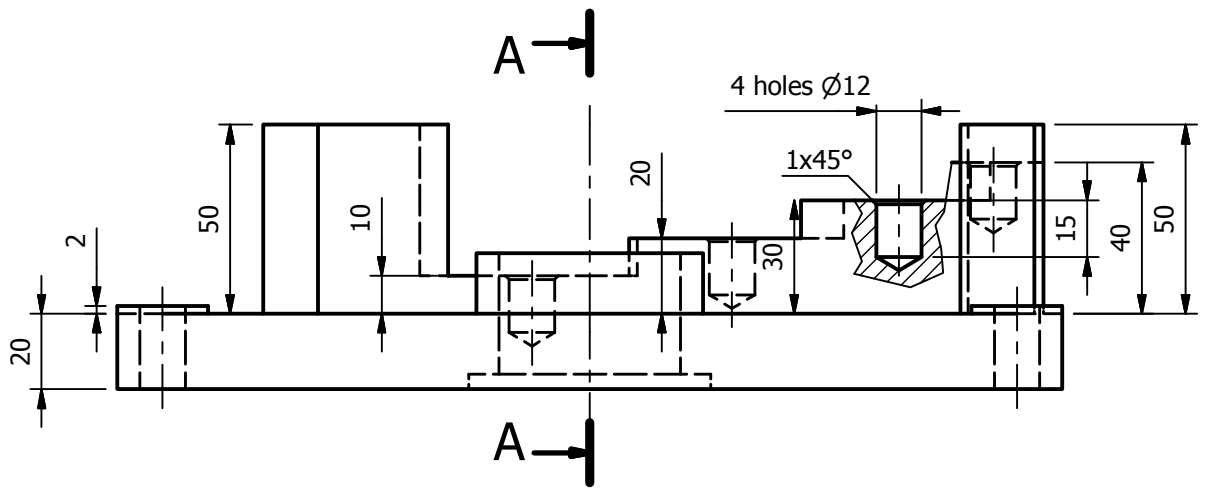

1033775.096 mm³

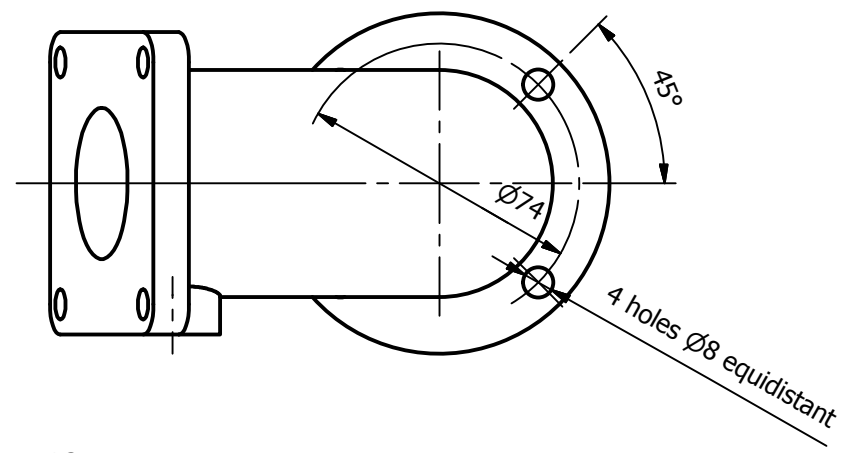
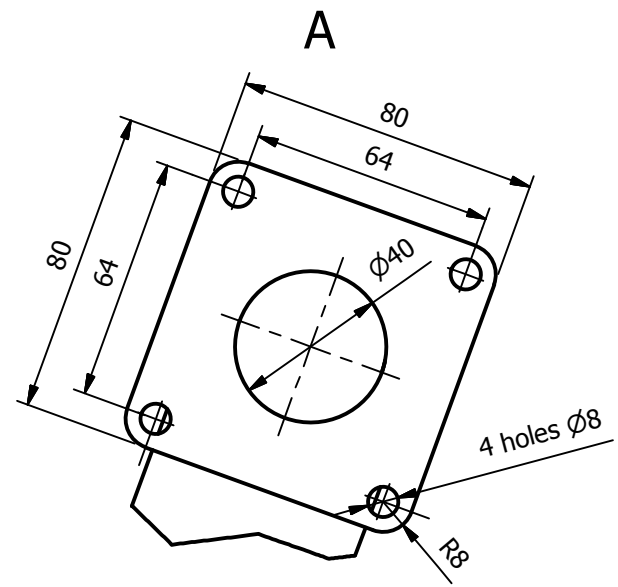
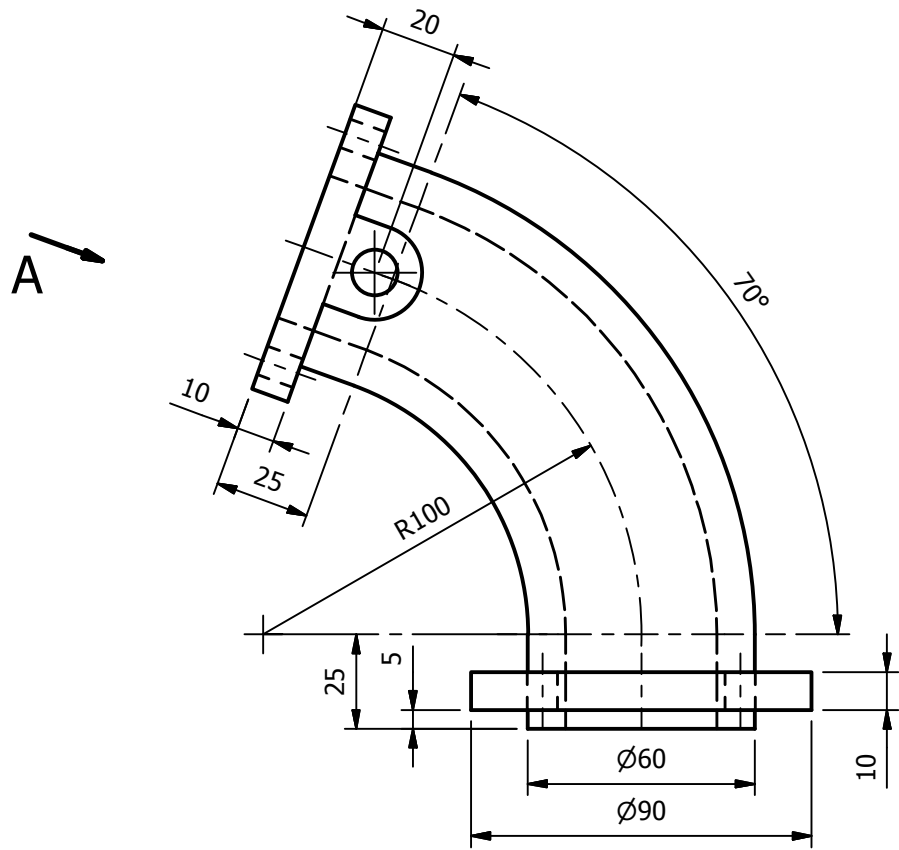

339935.240 mm³

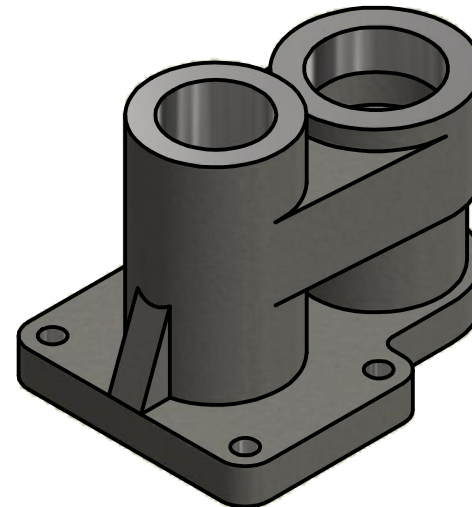
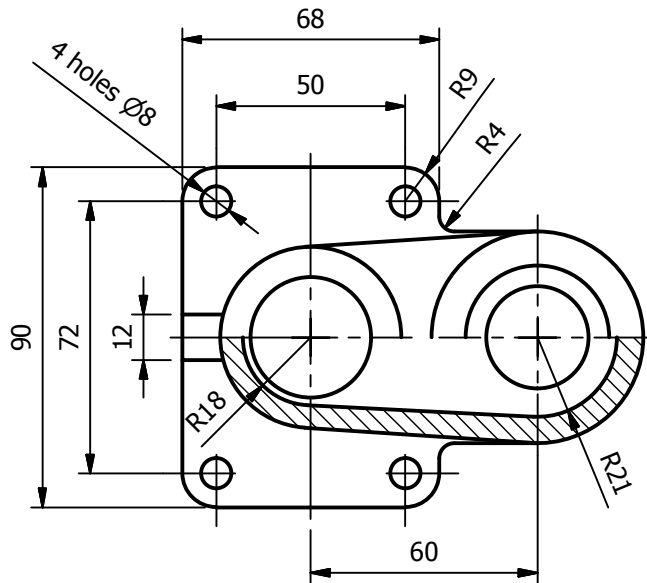
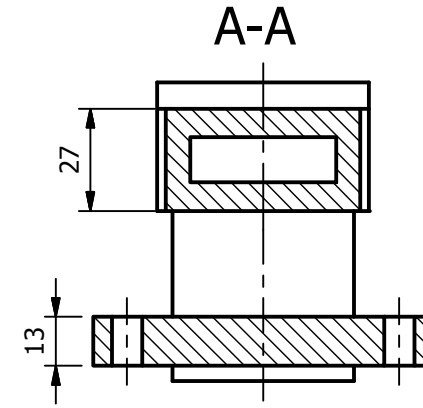
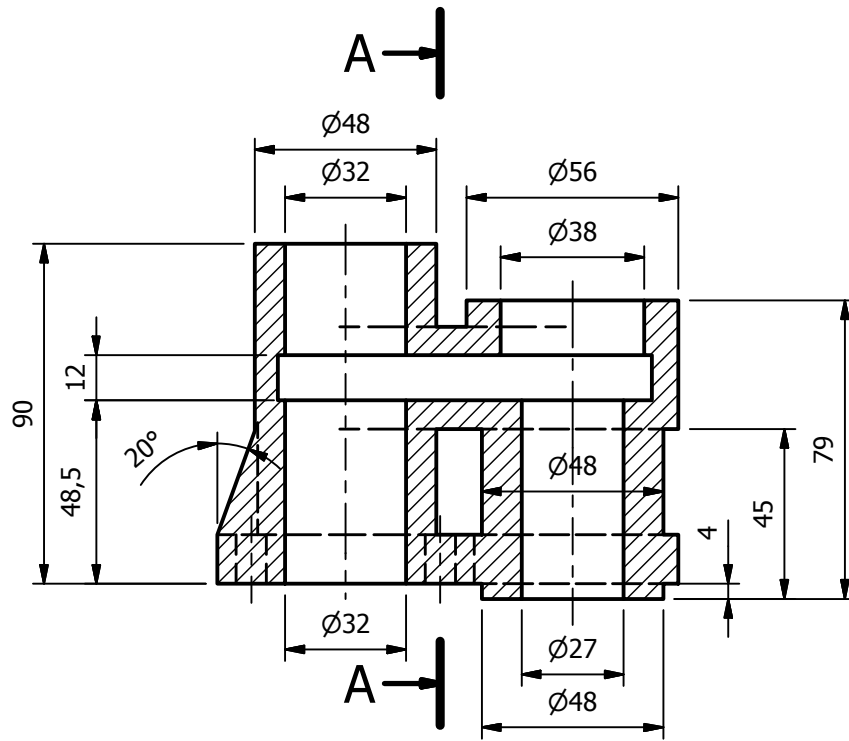

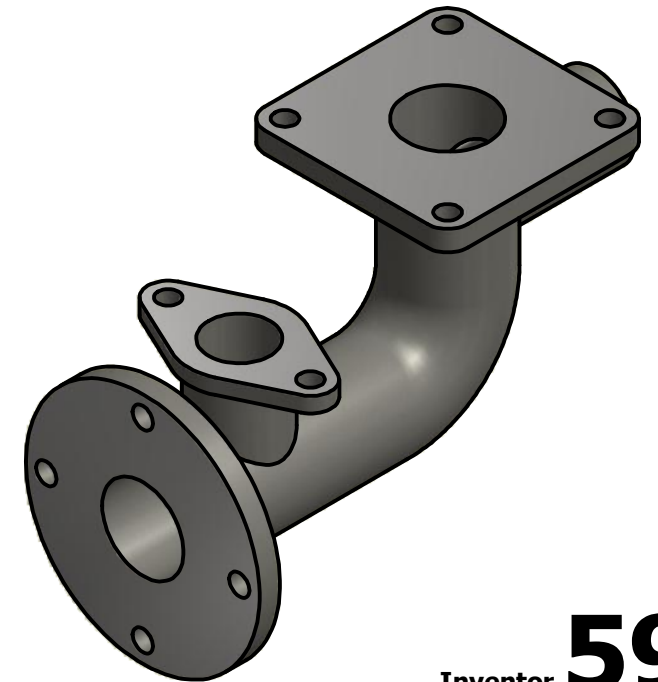
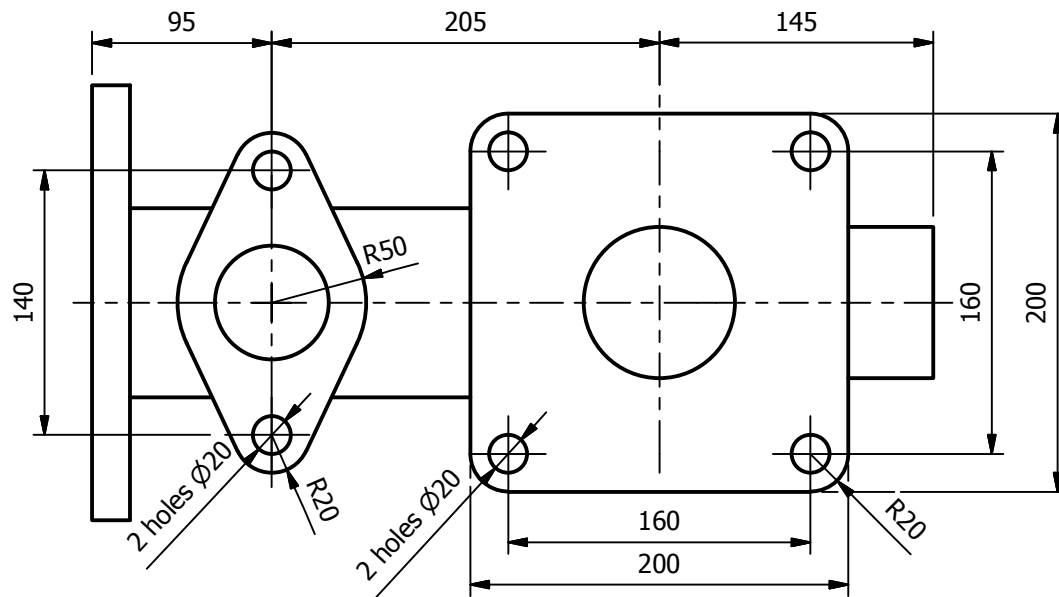
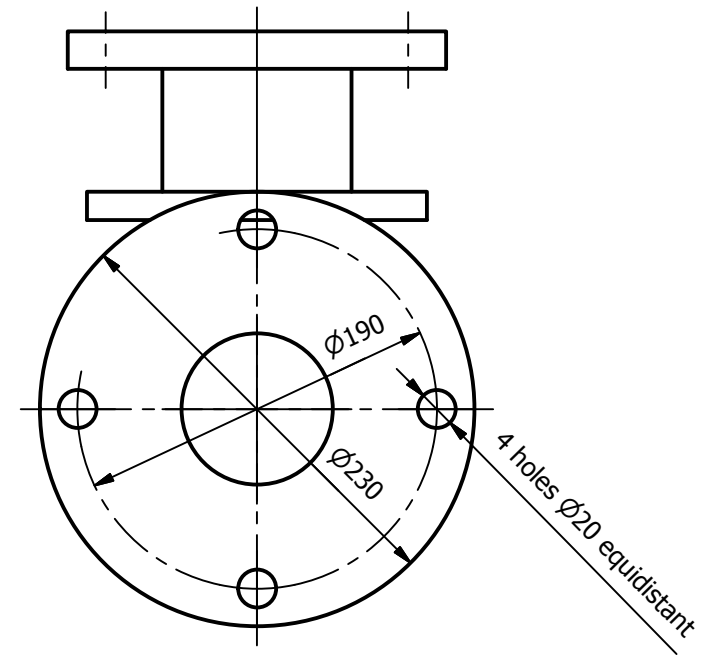
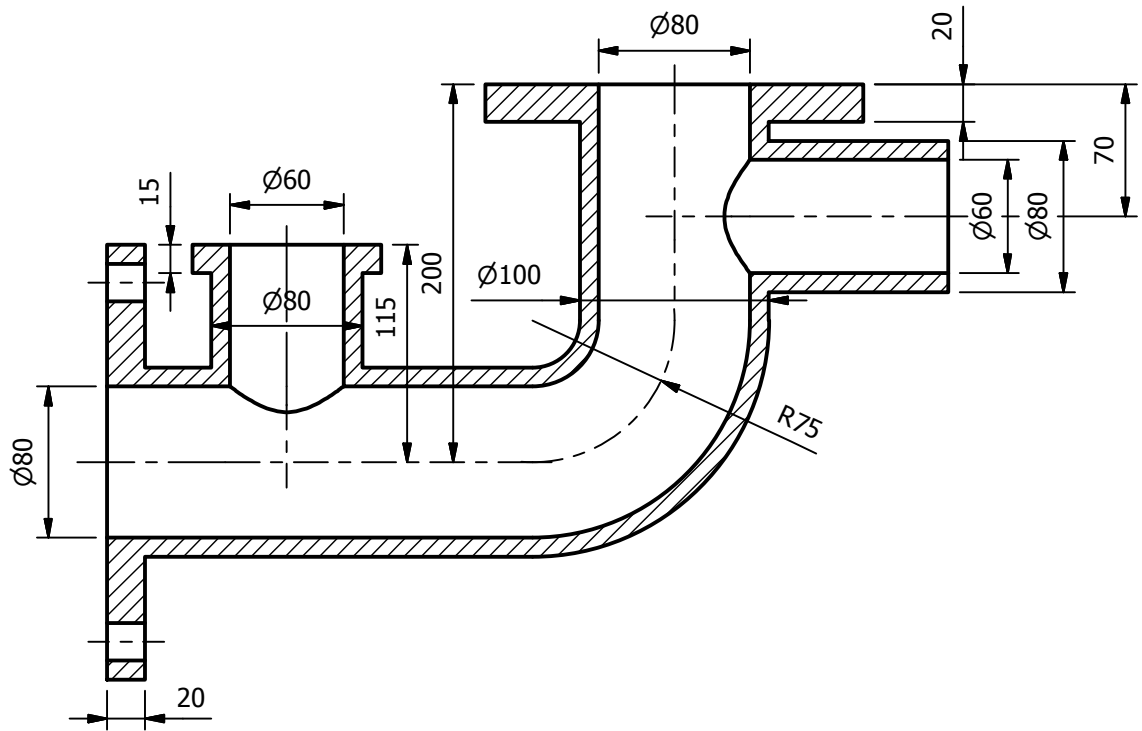

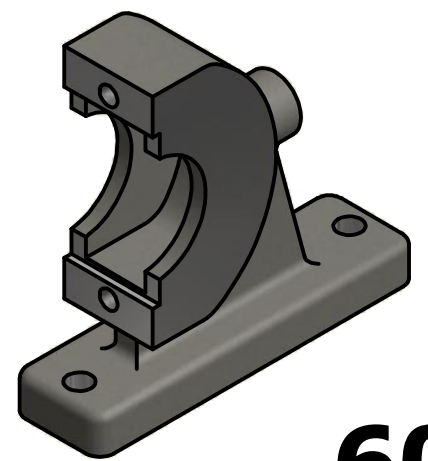
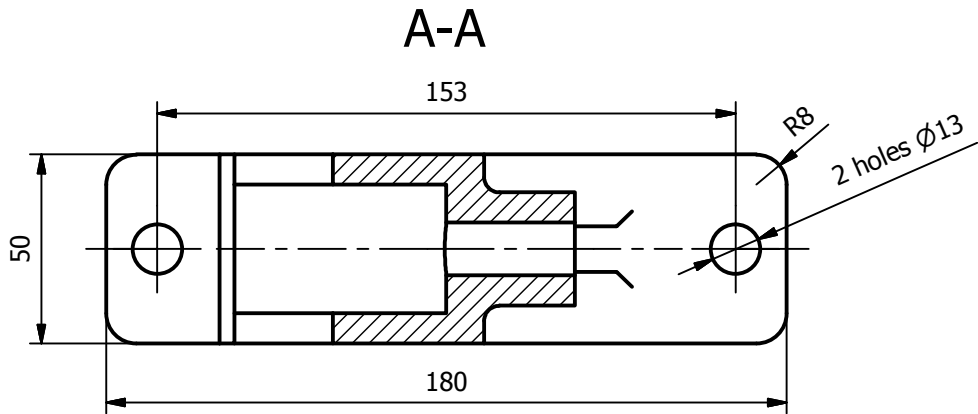
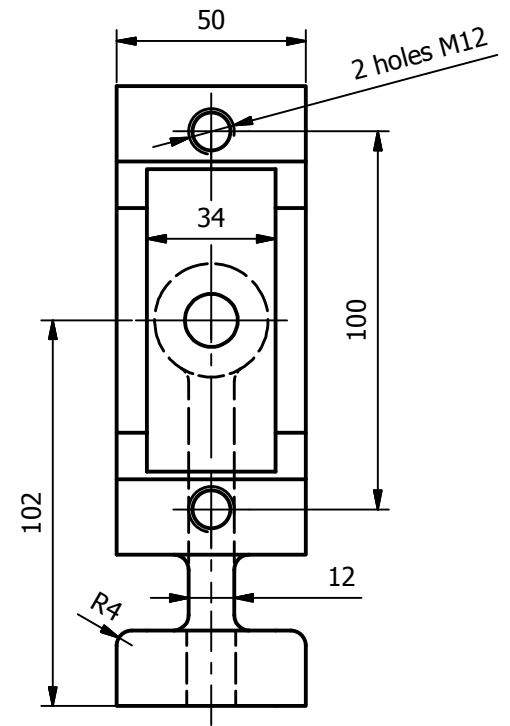
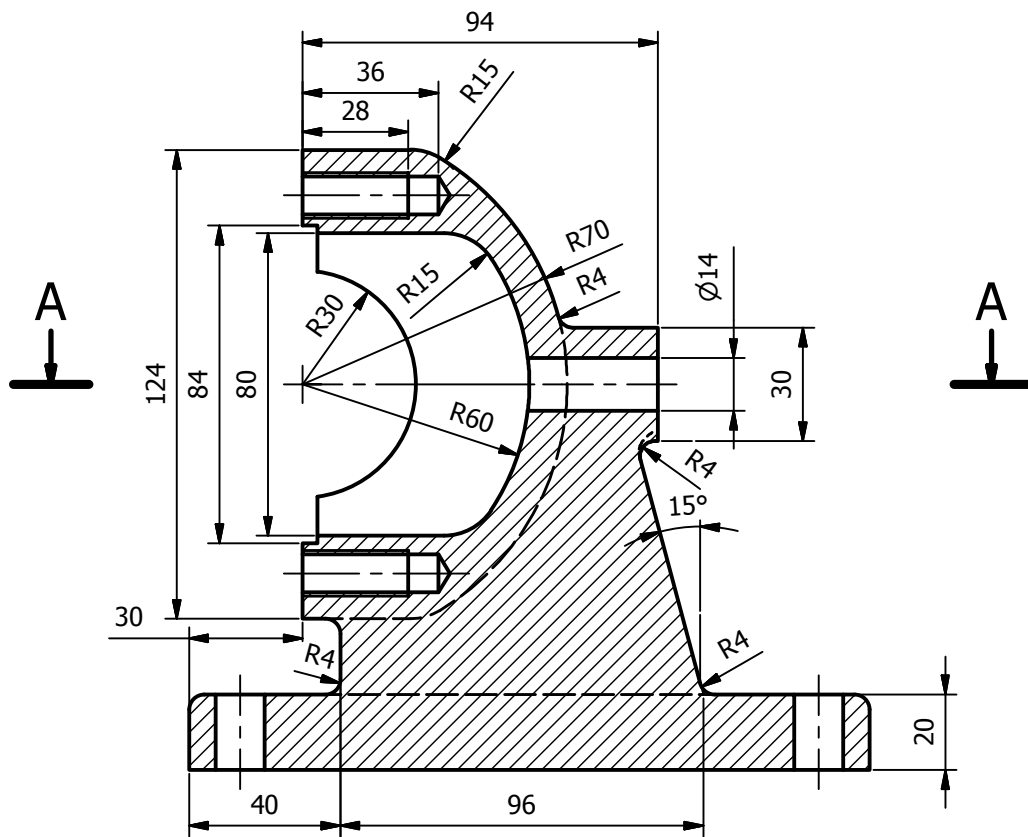

416914.753 mm³

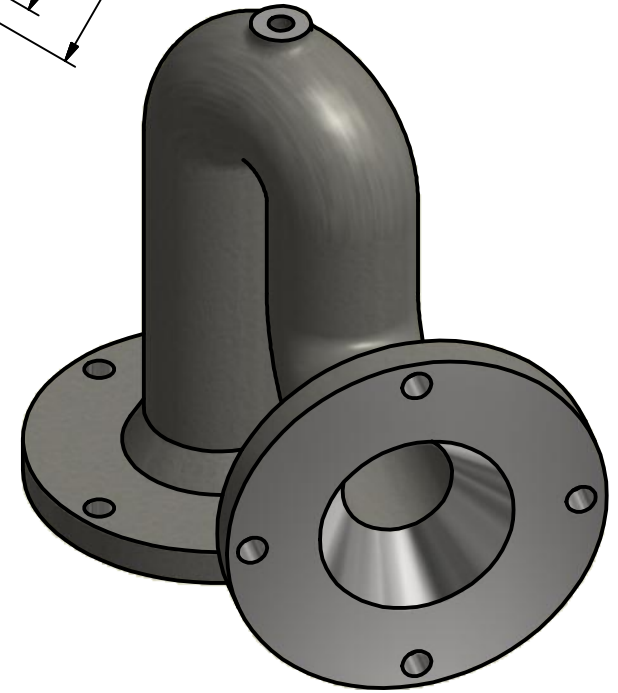
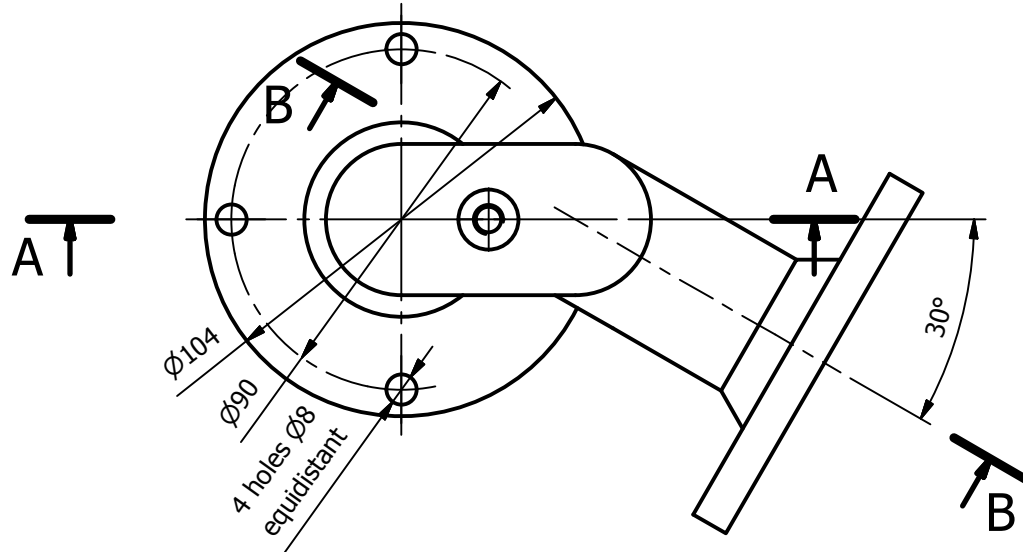
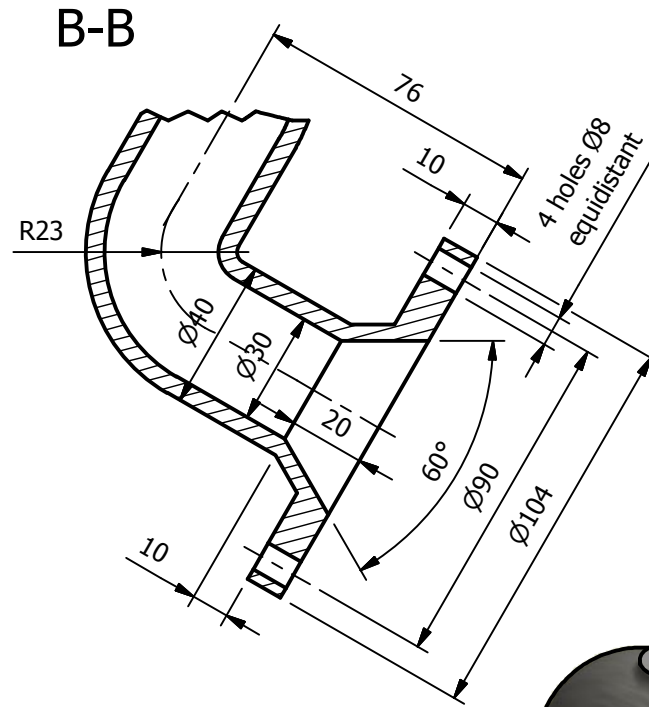
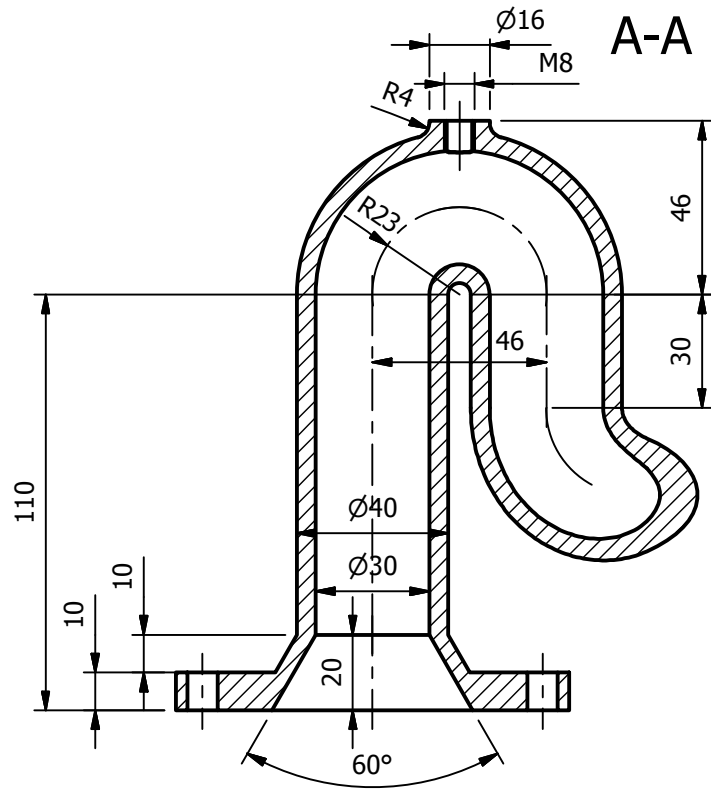

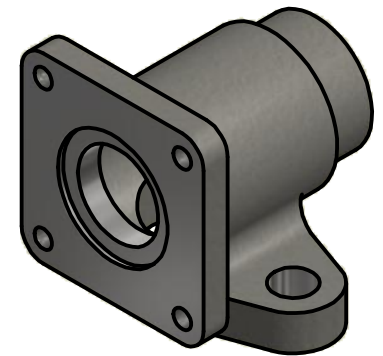
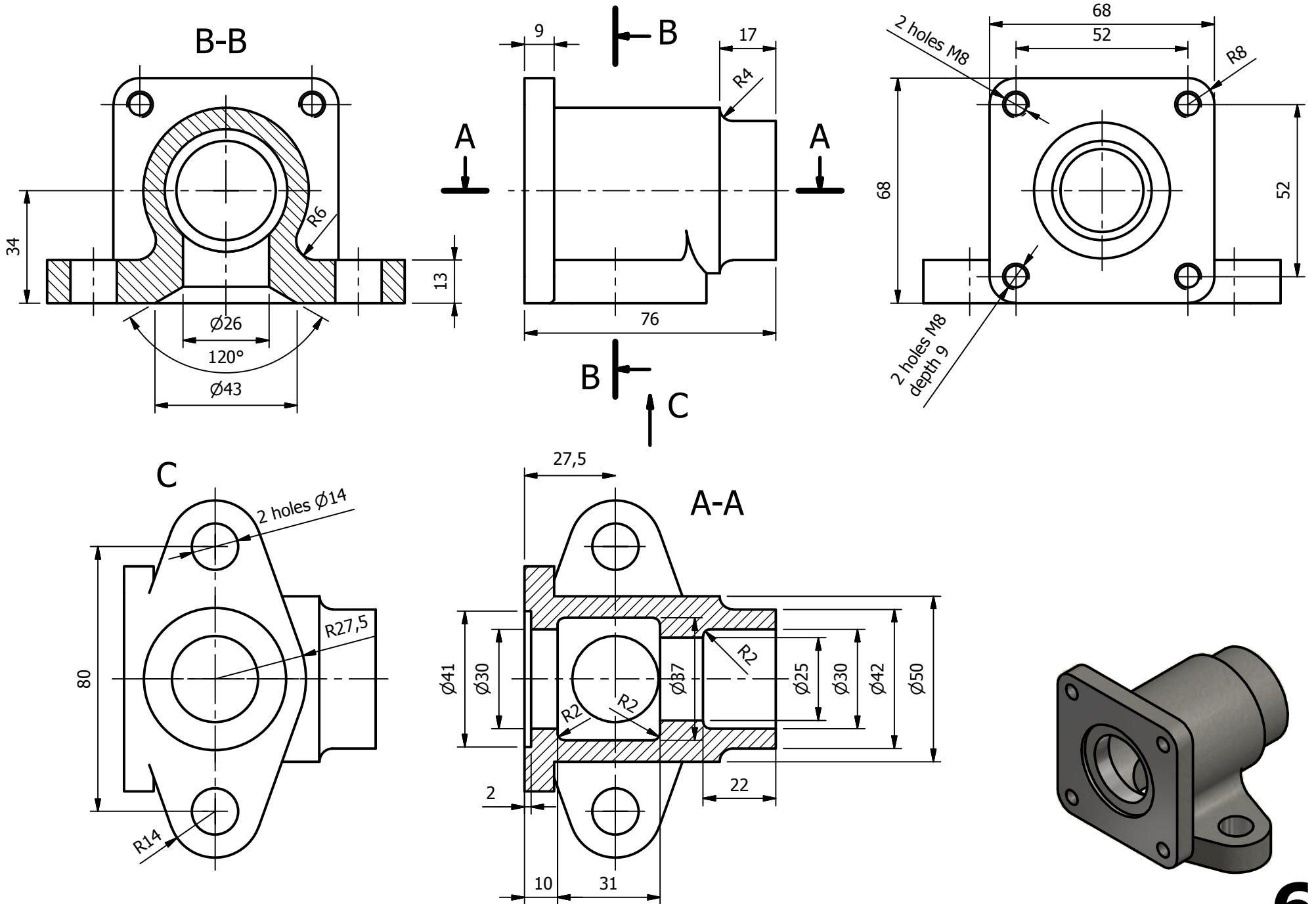

132724.206 mm³

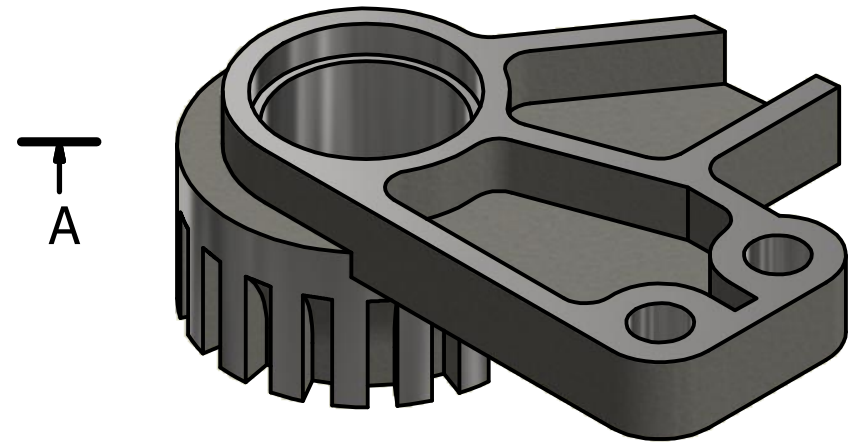
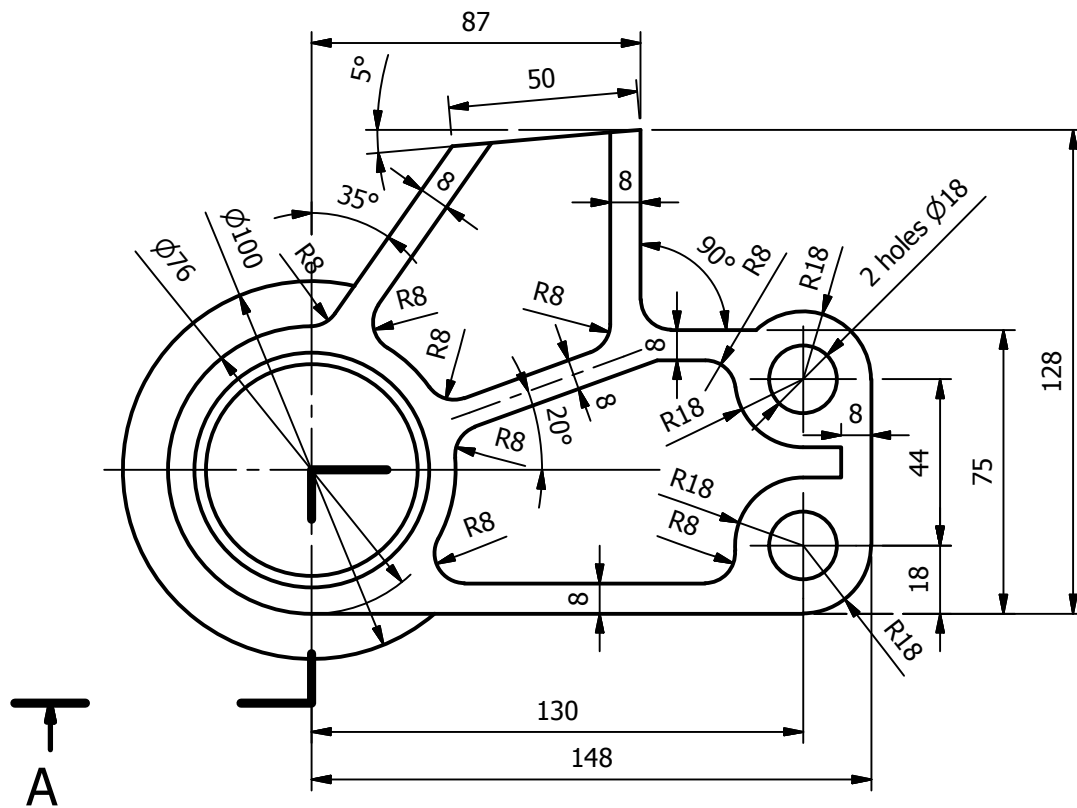
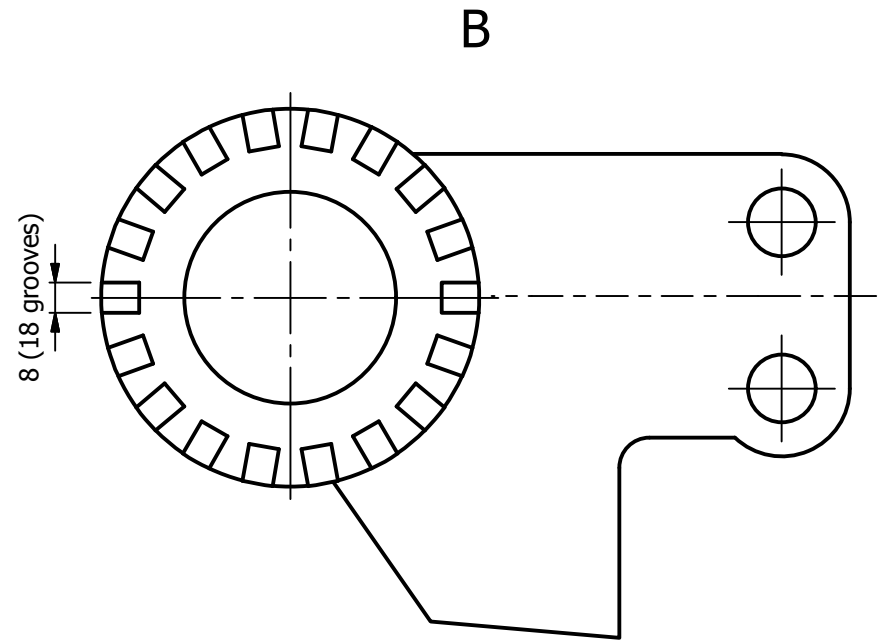
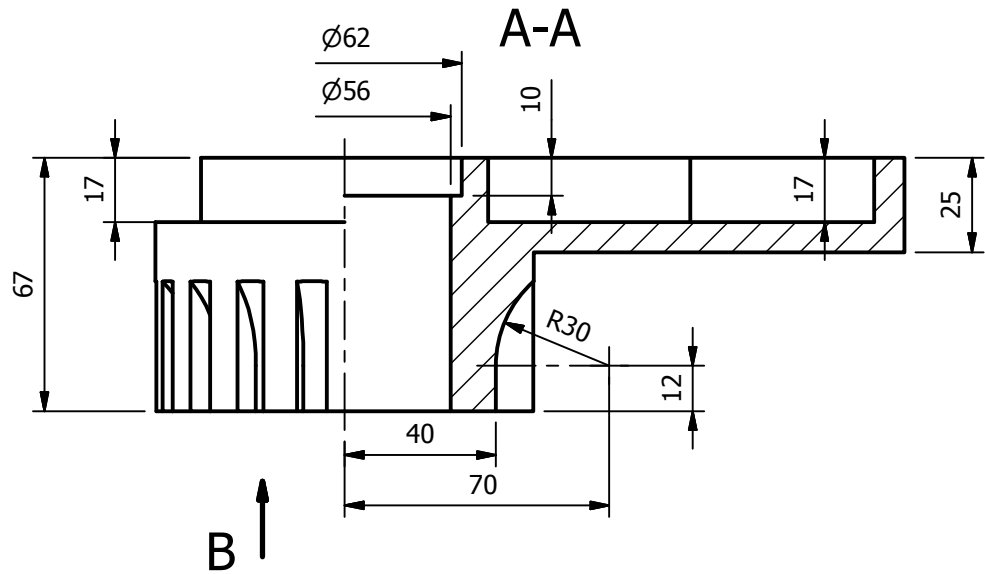

415970.176 mm³

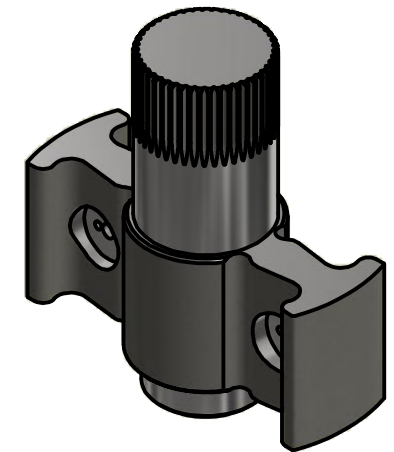
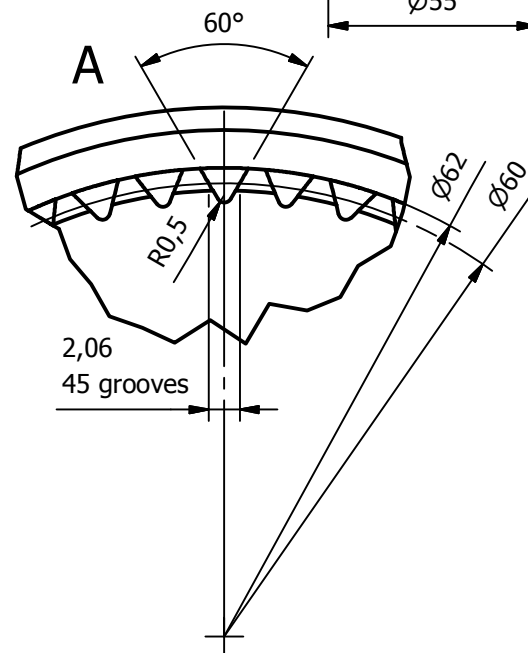
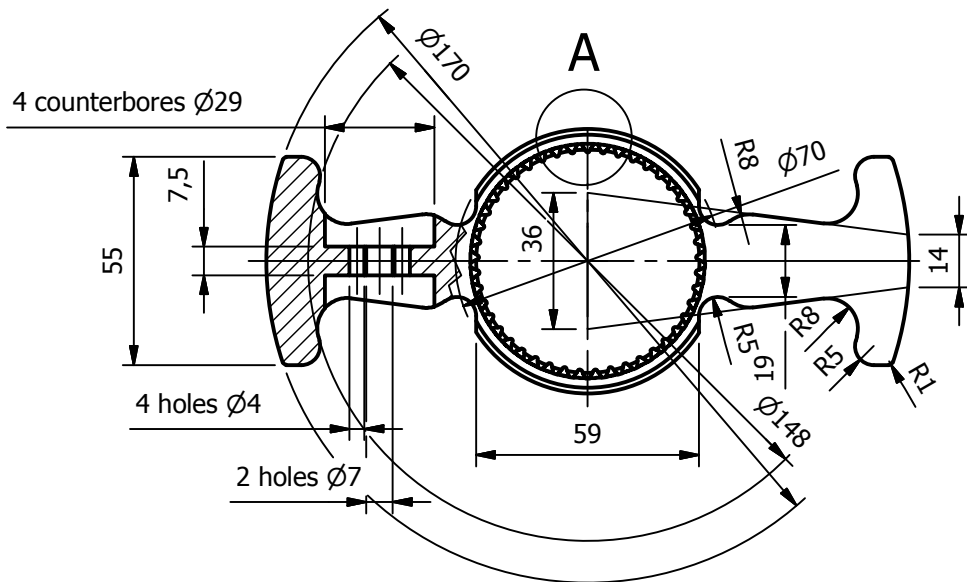
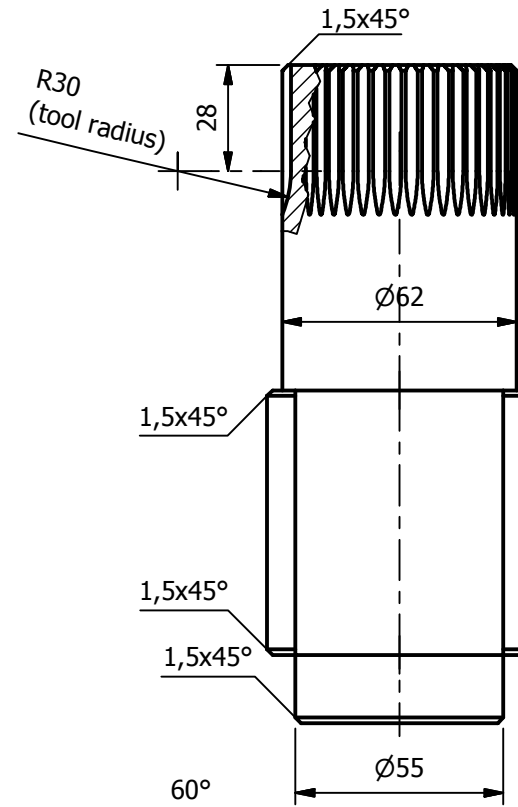
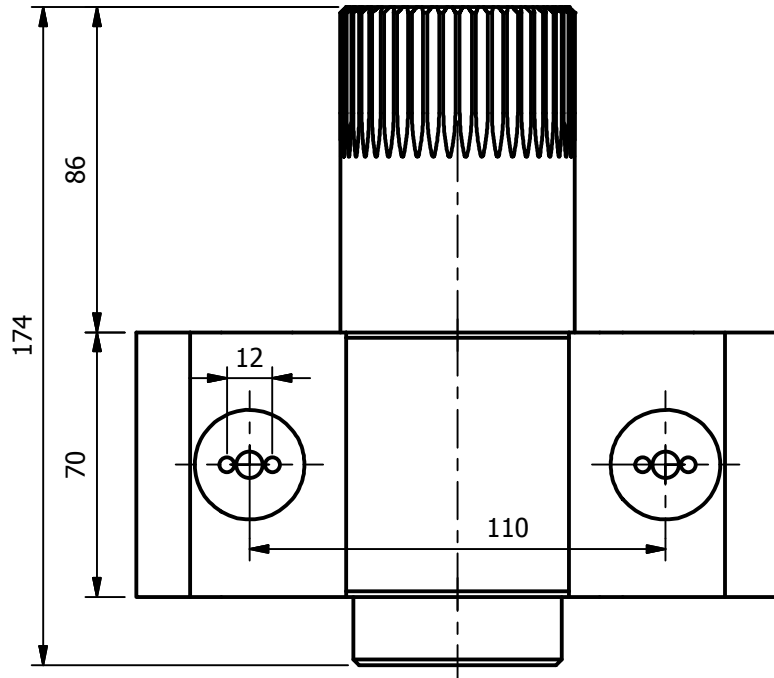

747534.832 mm³

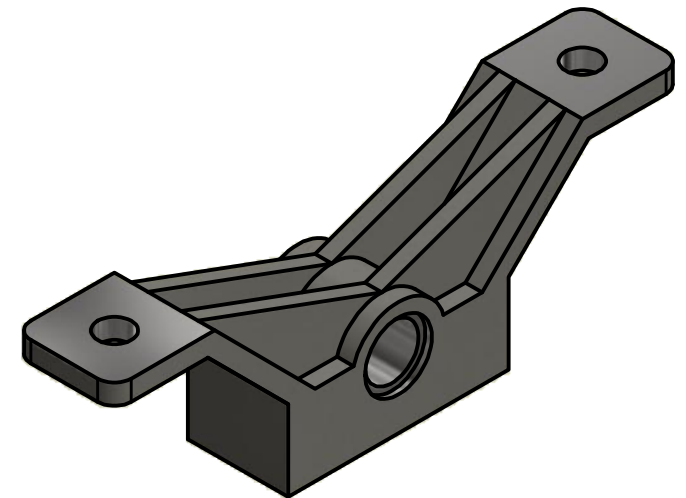
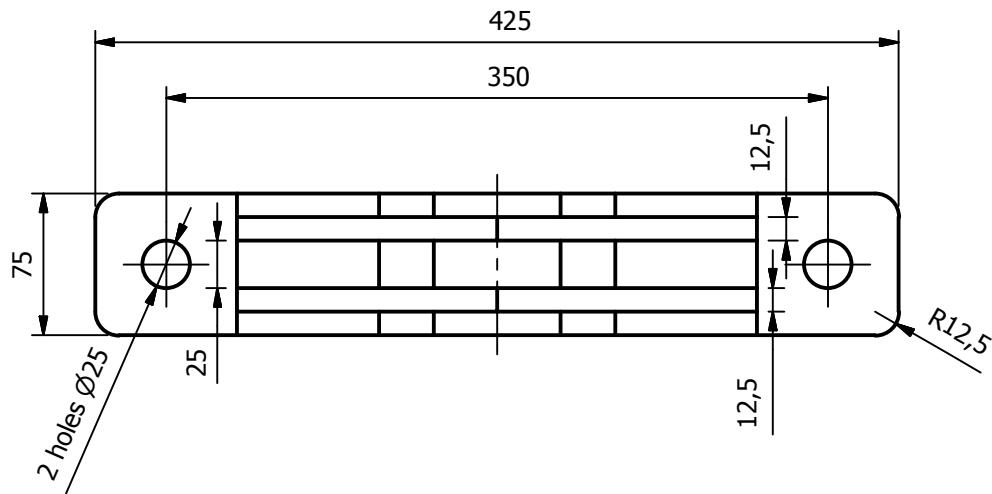
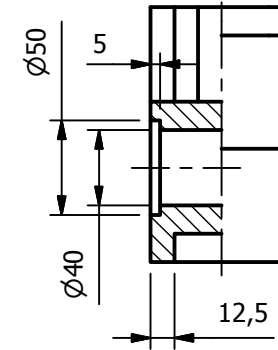
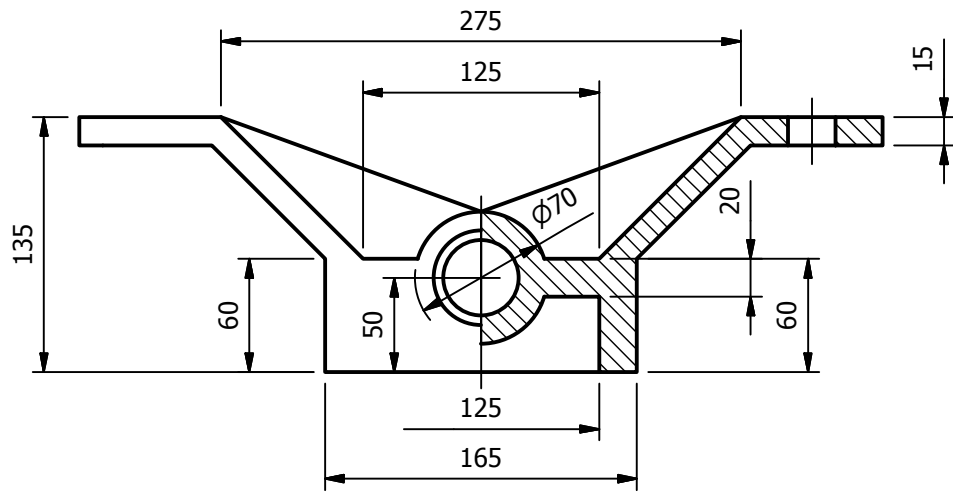

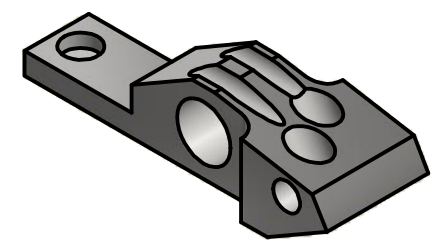
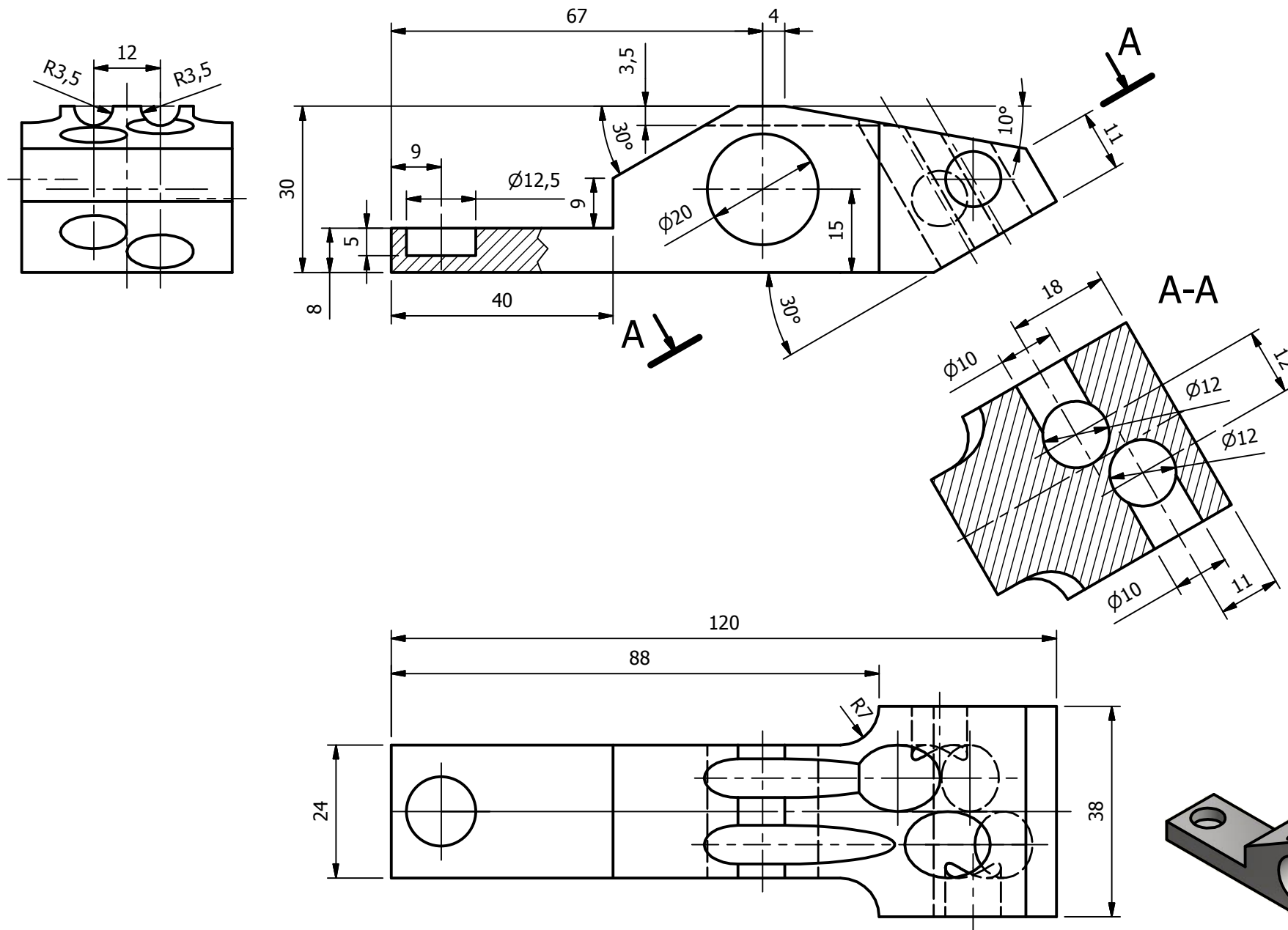

46485.411 mm³

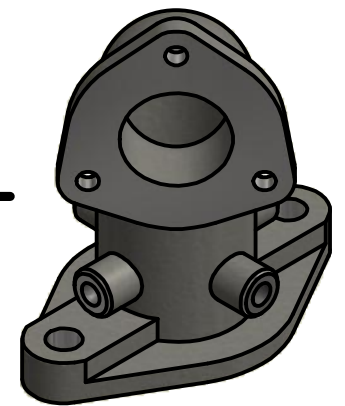
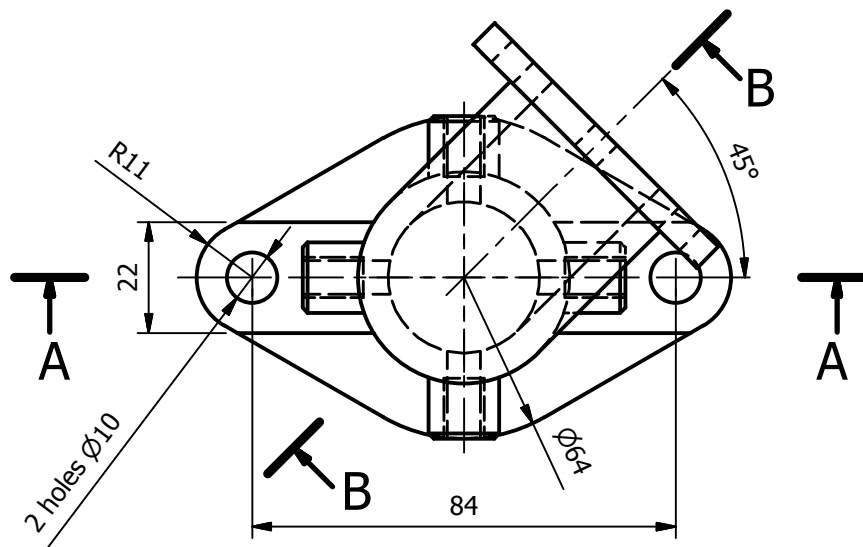
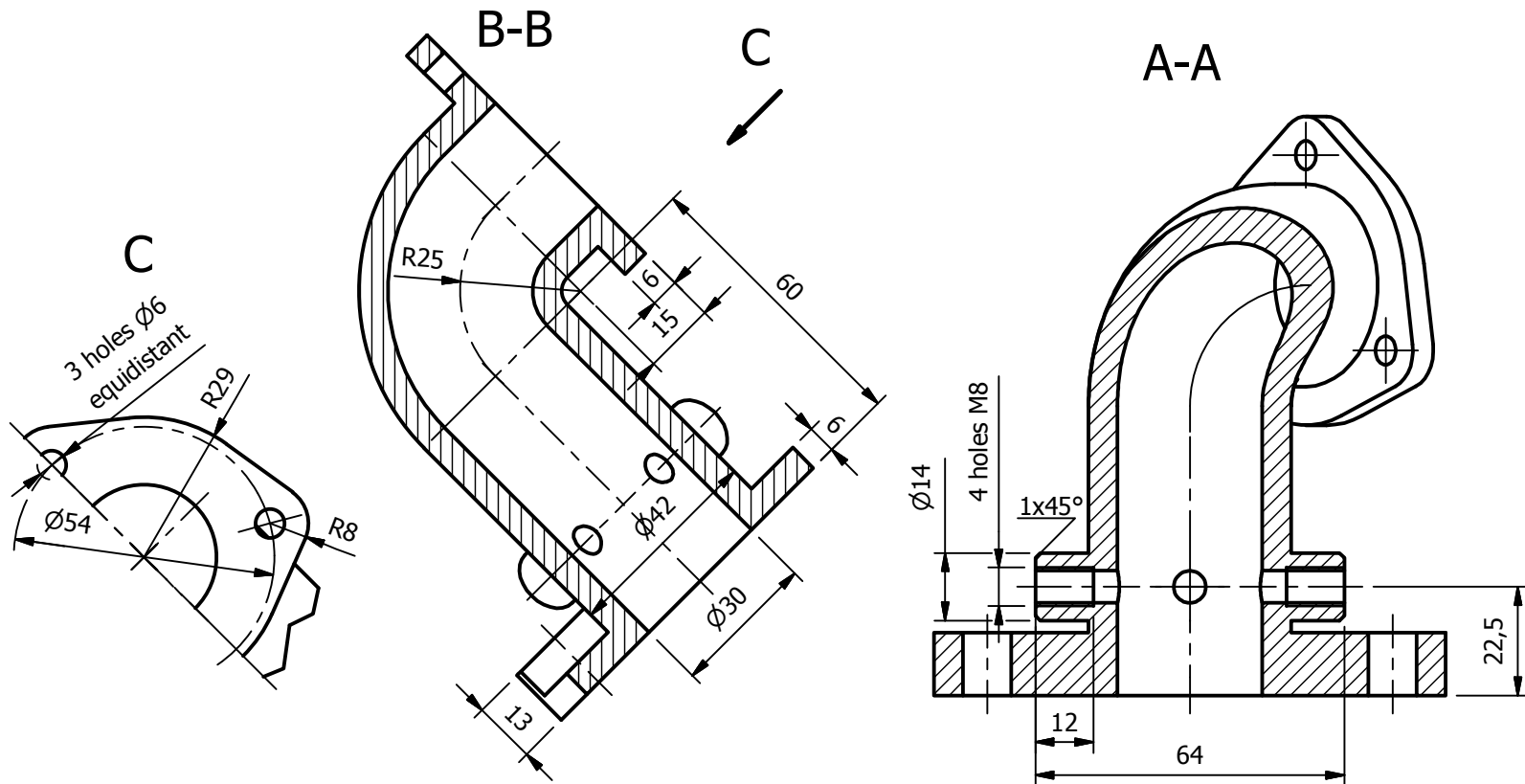

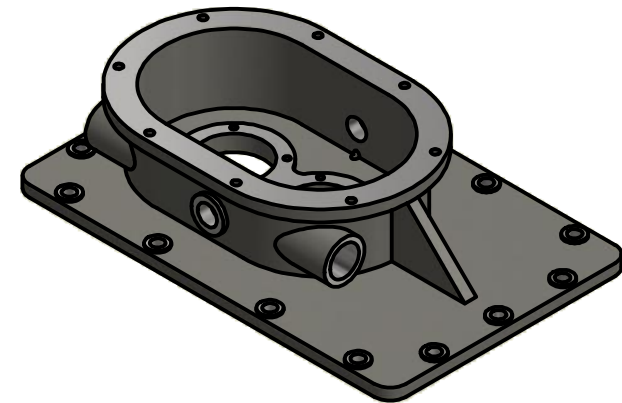
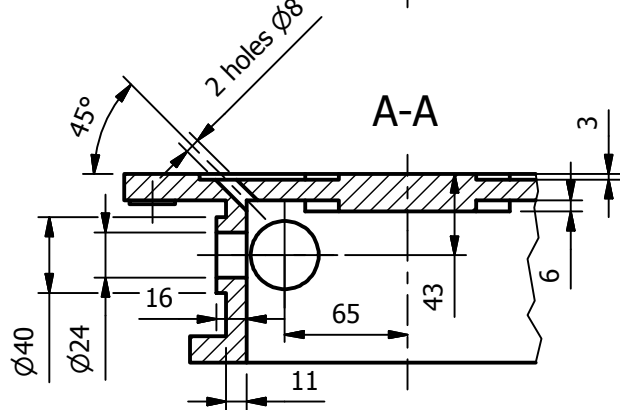
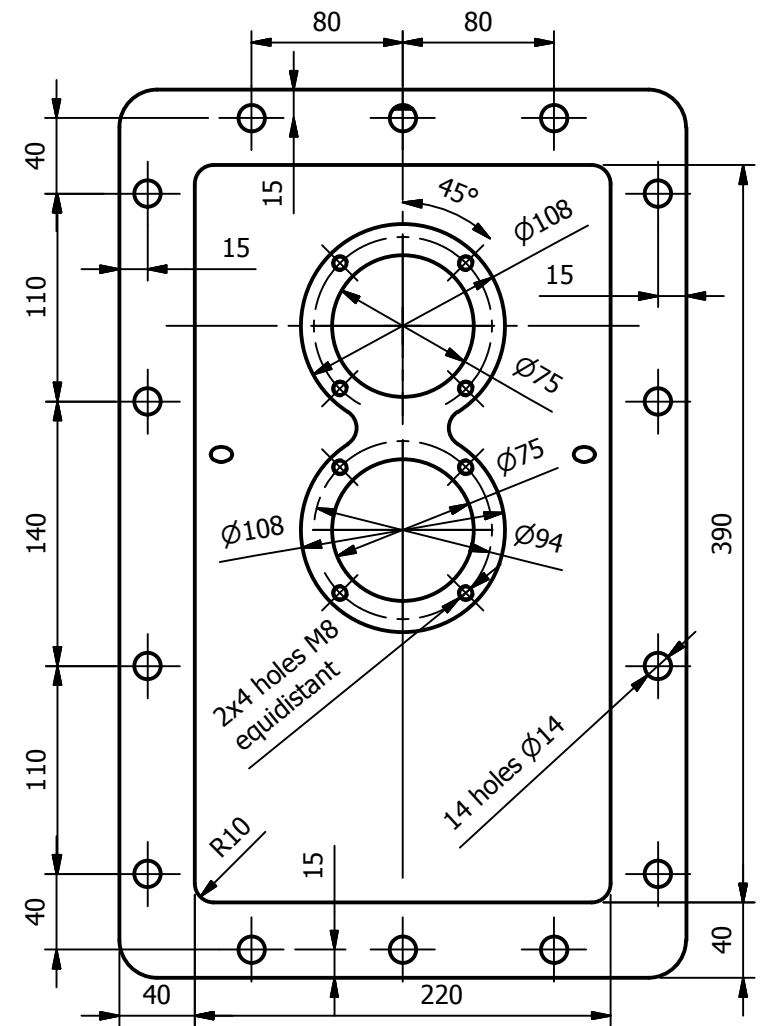
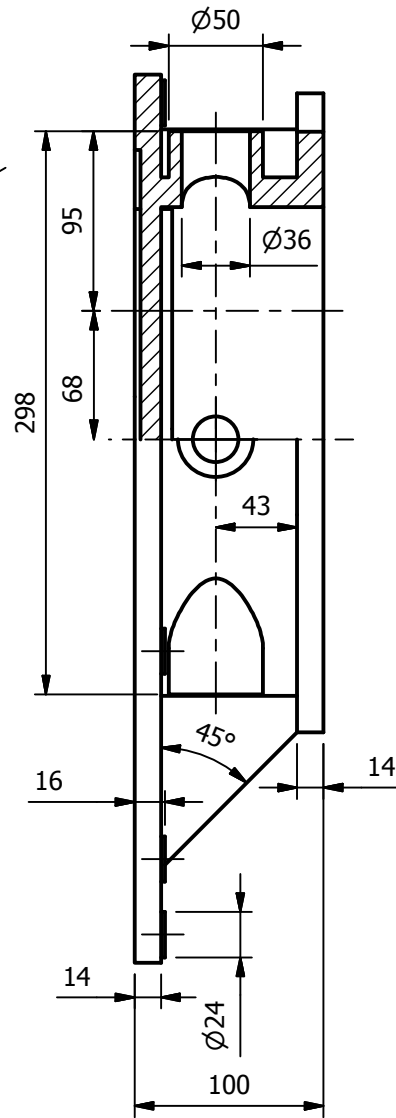
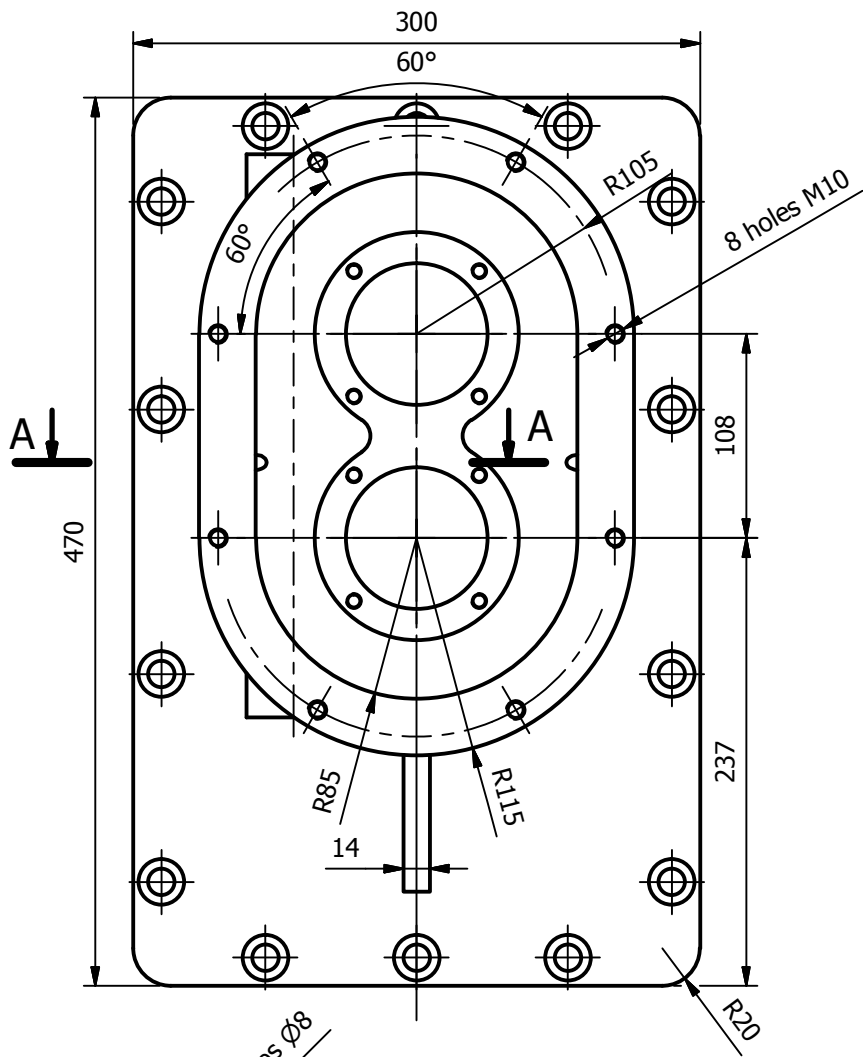

2714866.225 mm^3

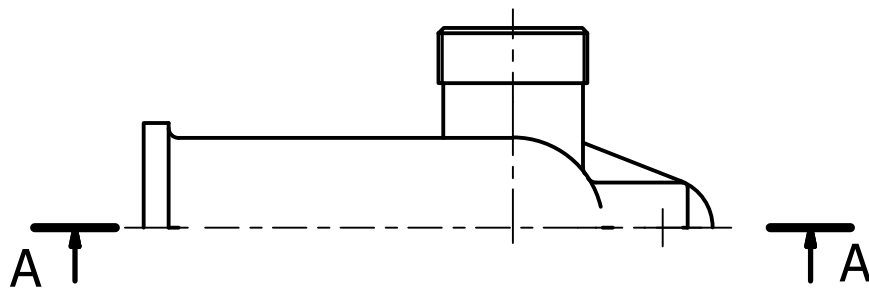
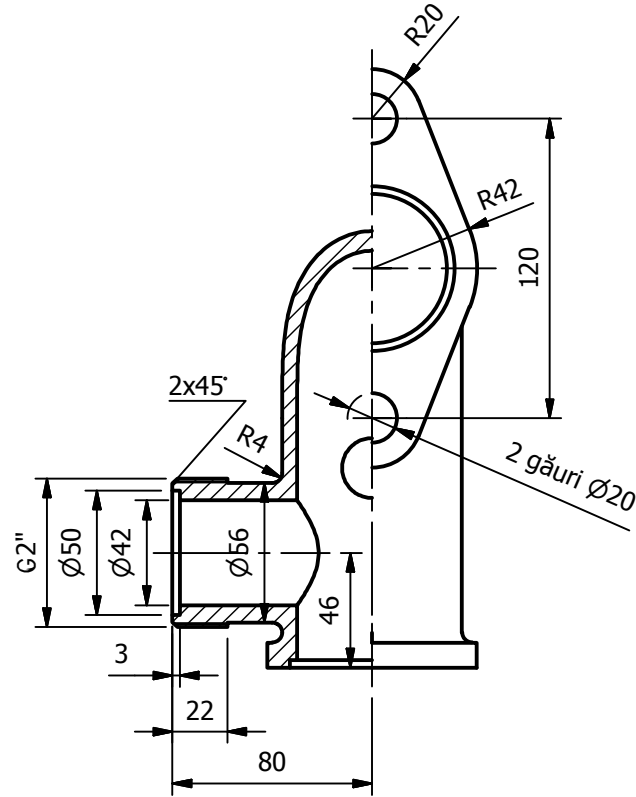
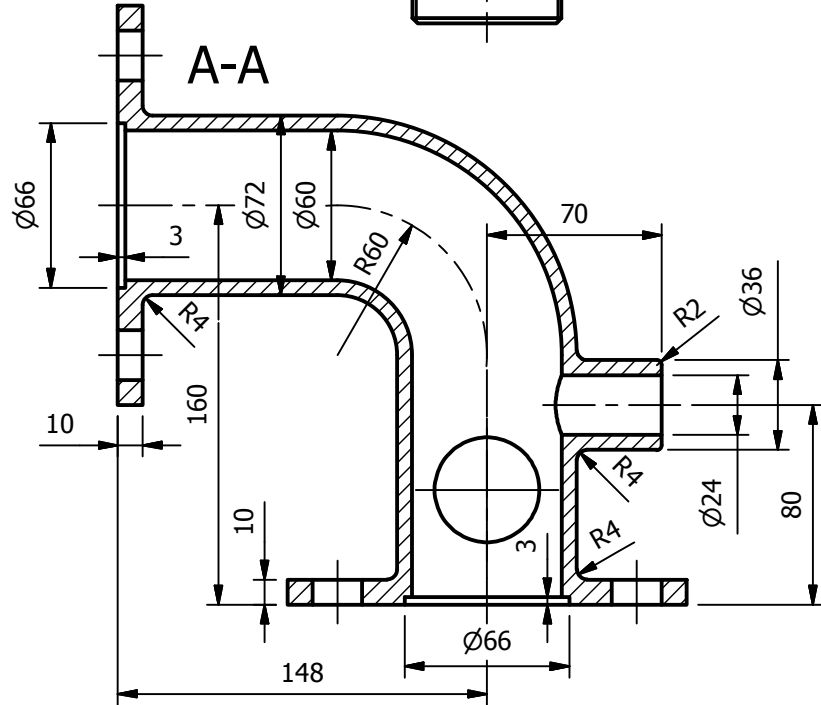
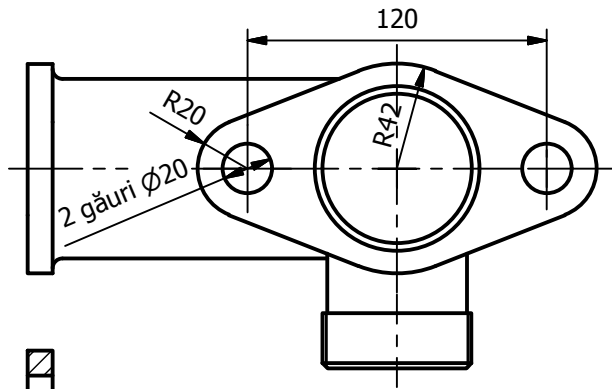

505885.027 mm³

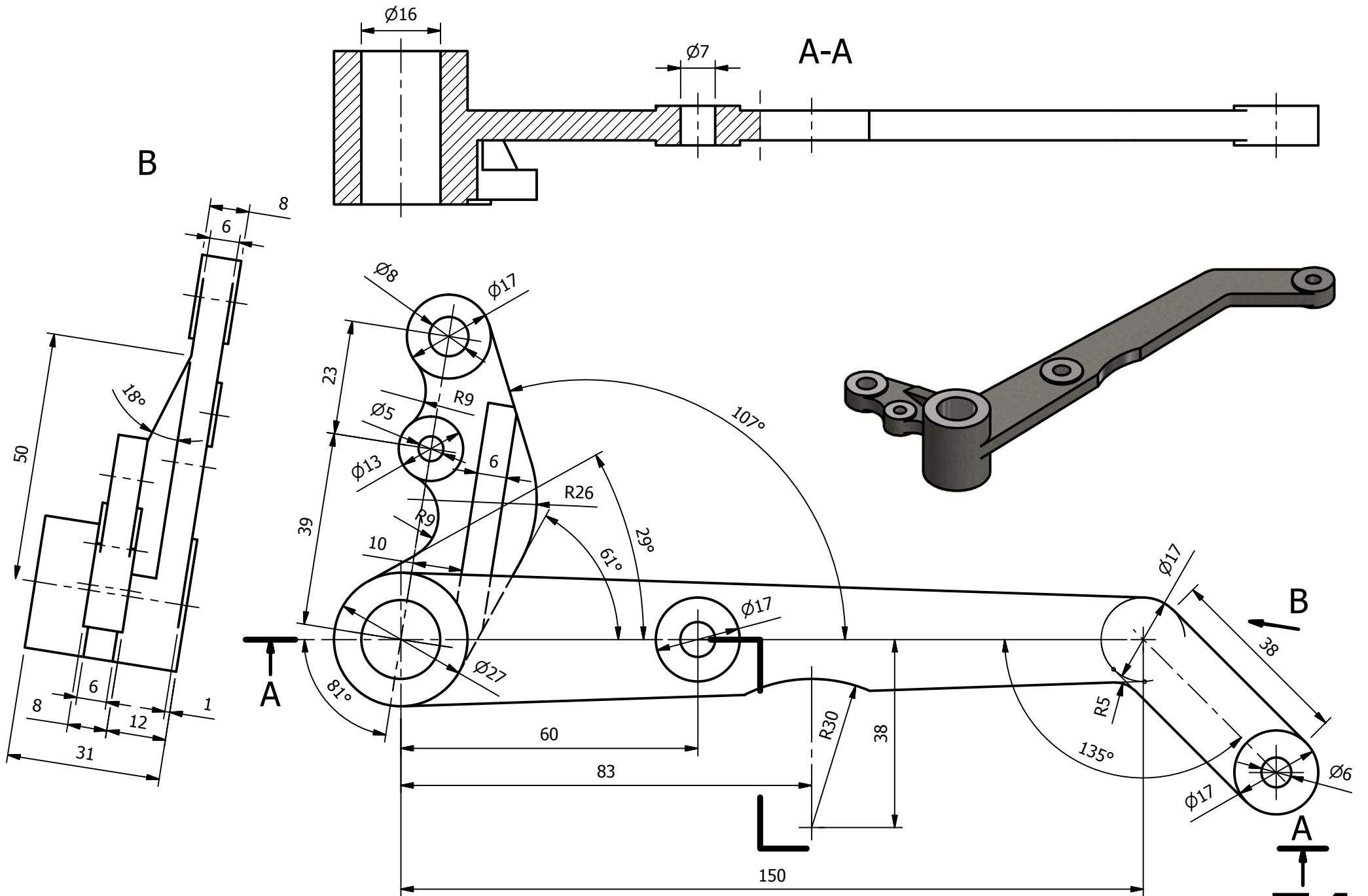

43373.133 mm³

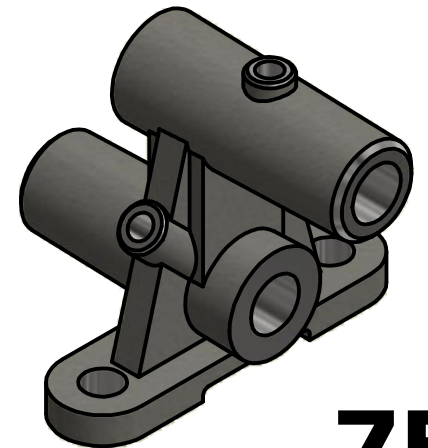
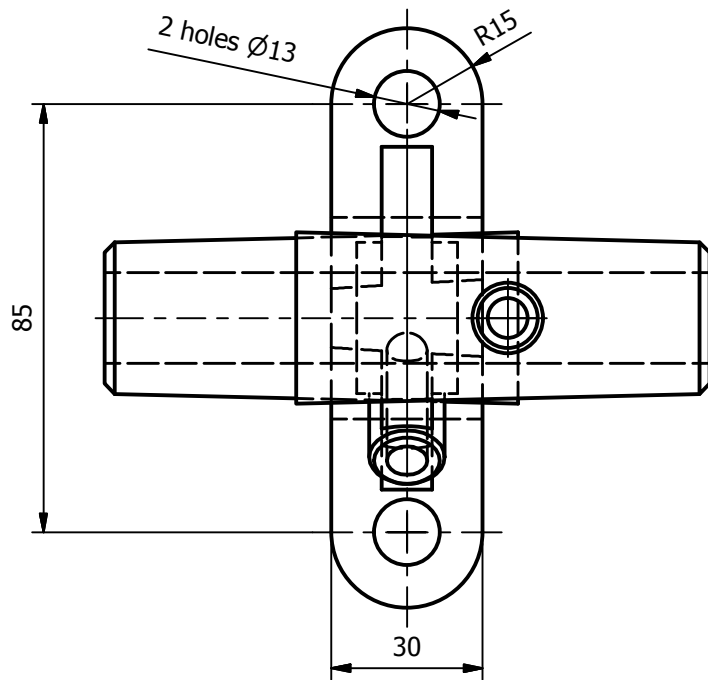
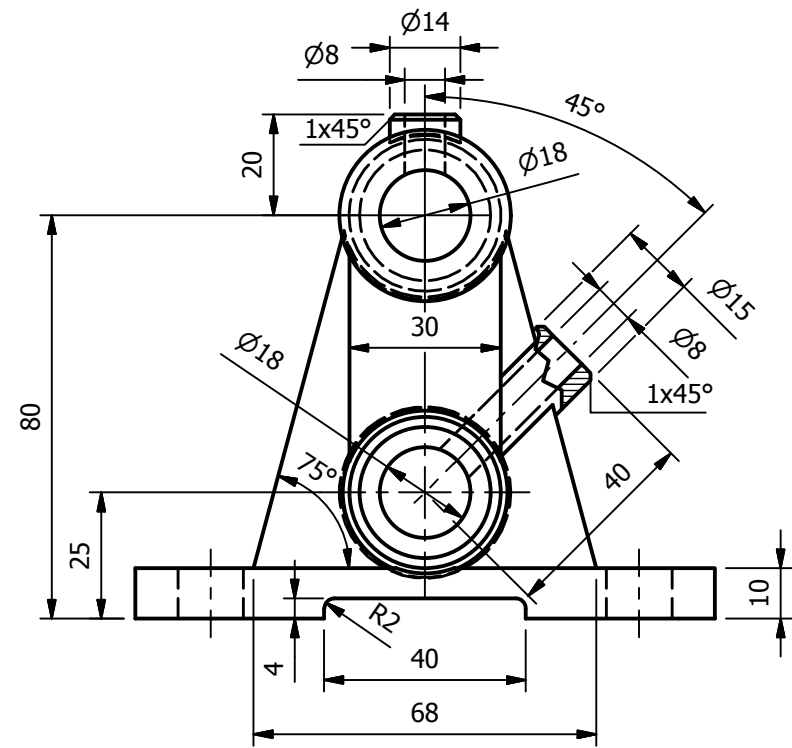
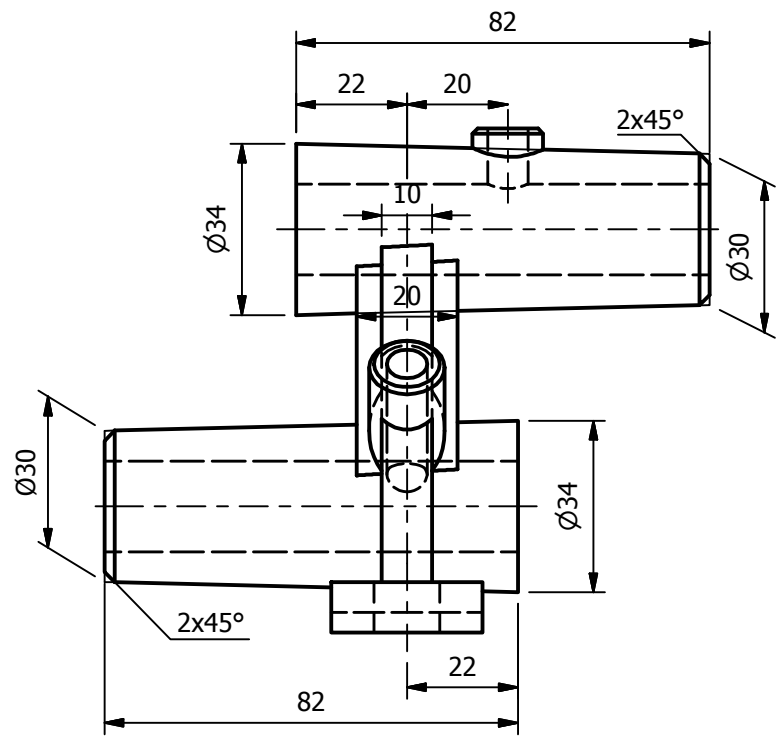

144993.492 mm³

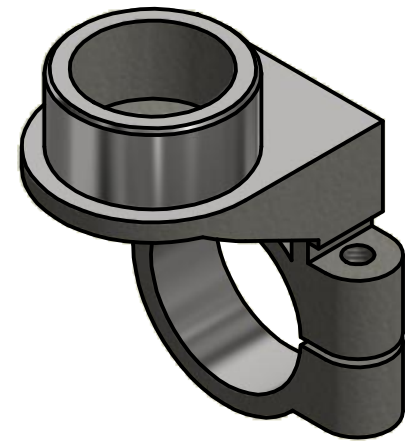
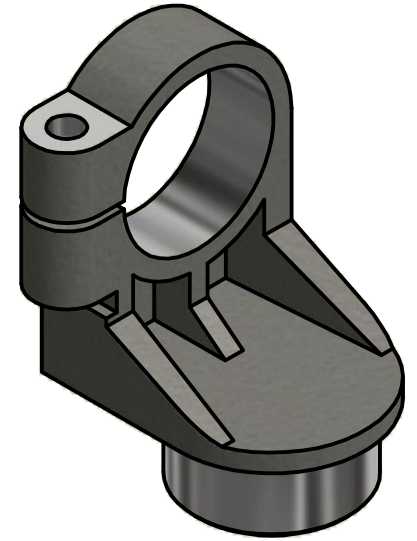
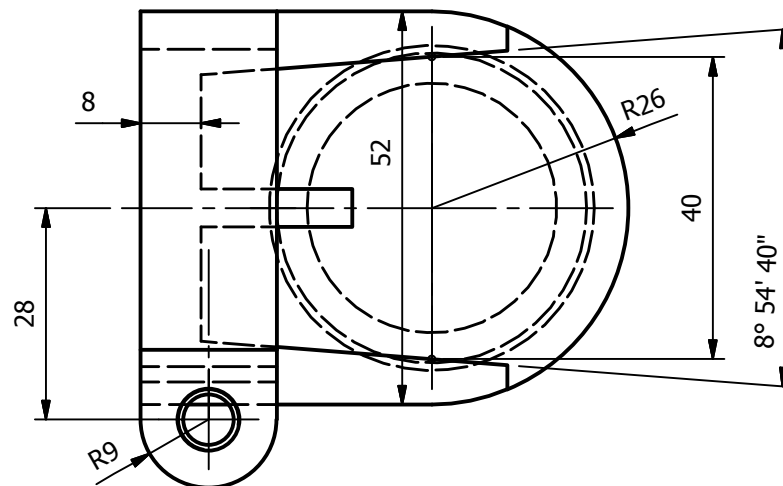
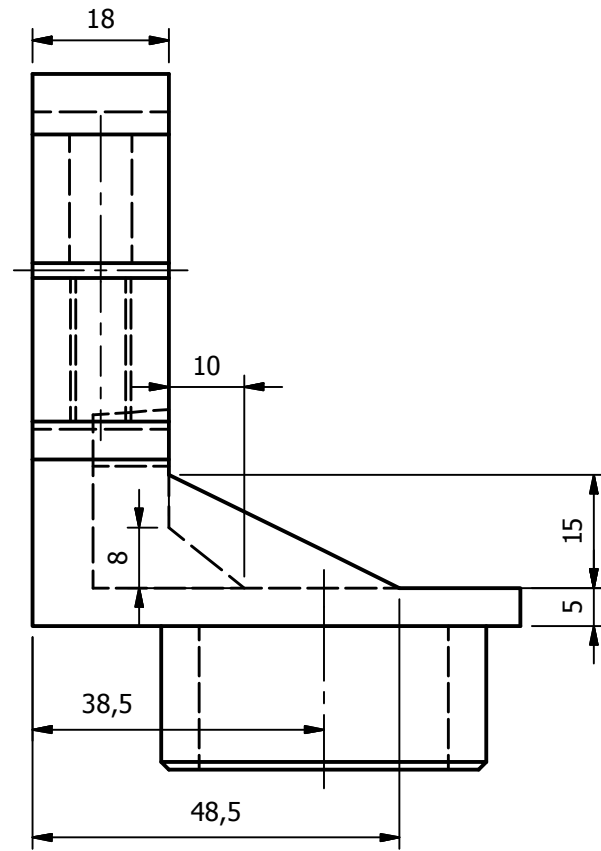
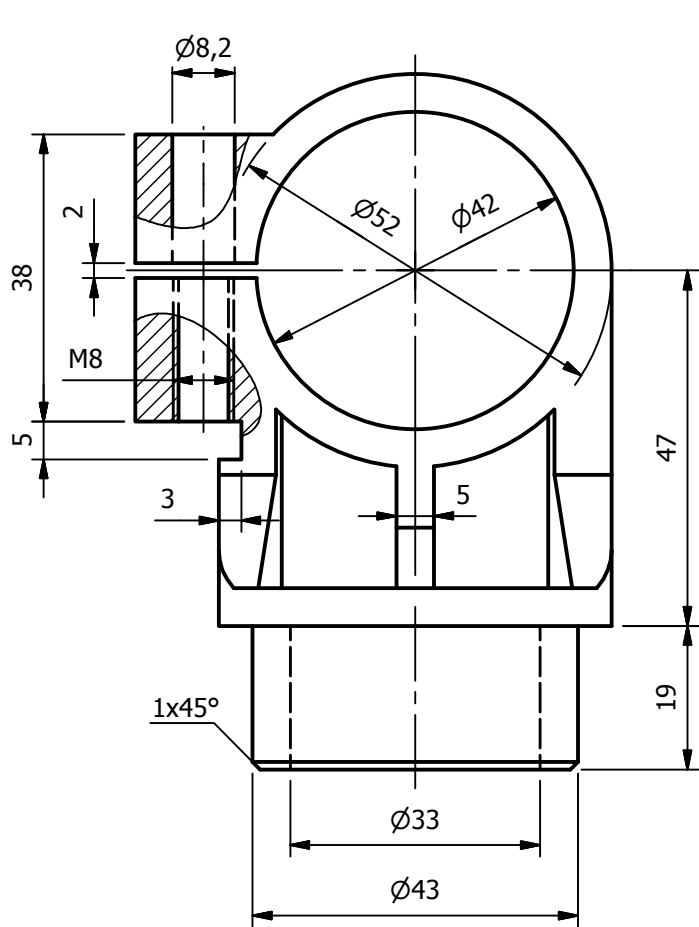

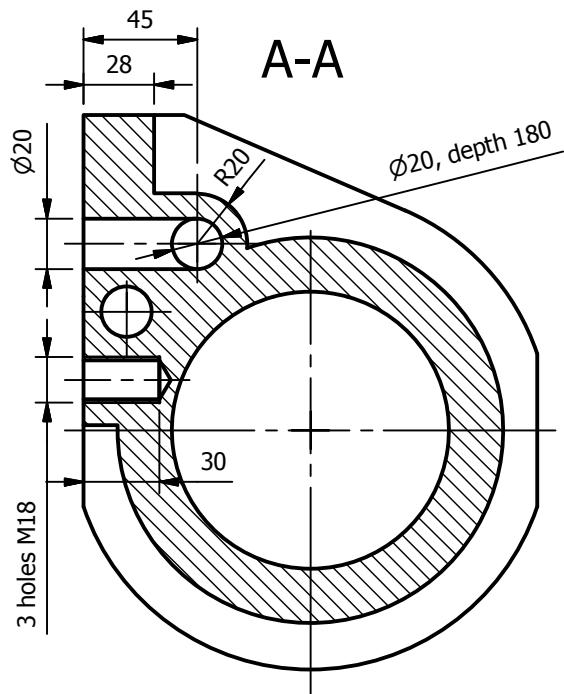

B-B (rotated)

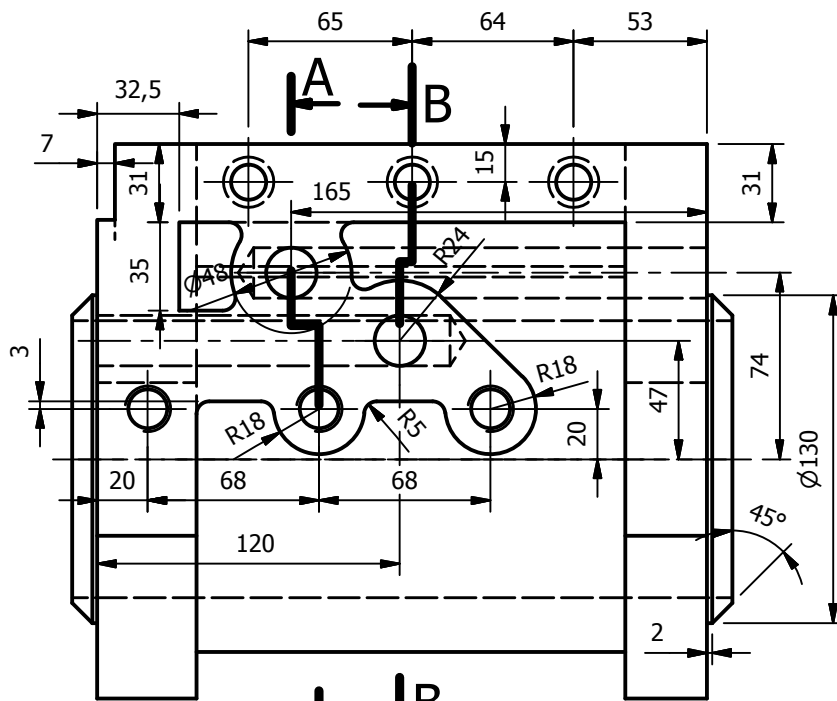
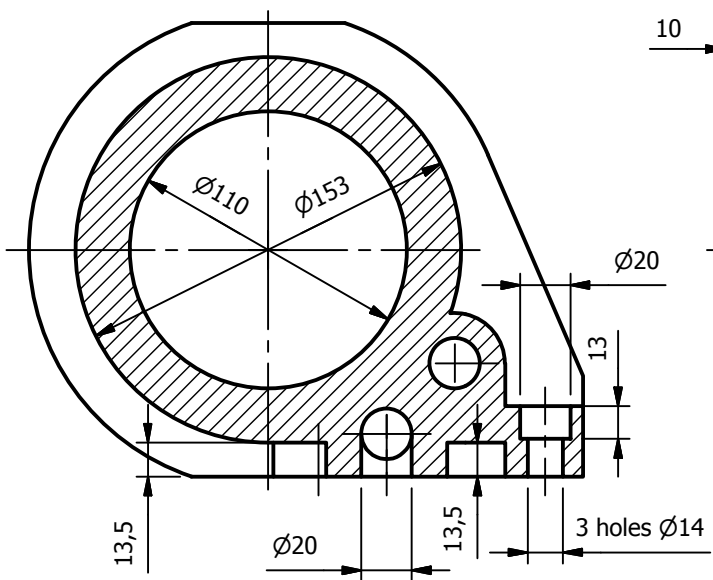

A-B

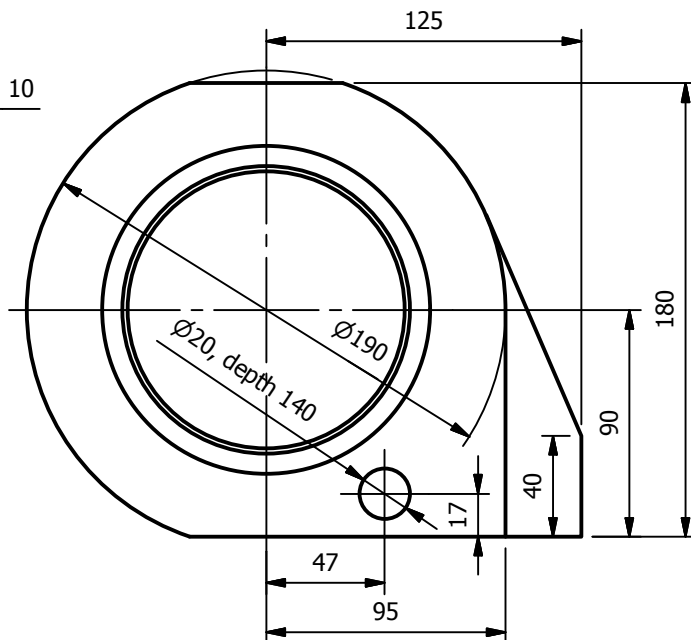
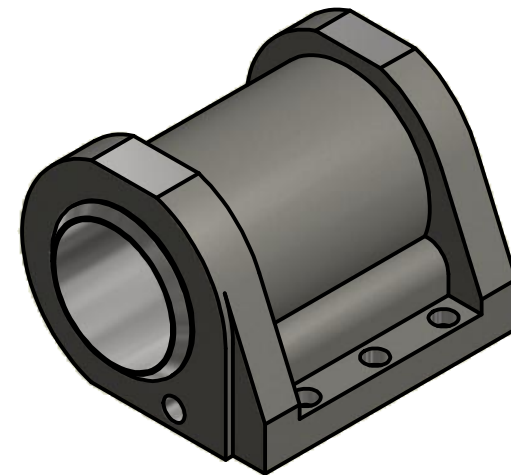
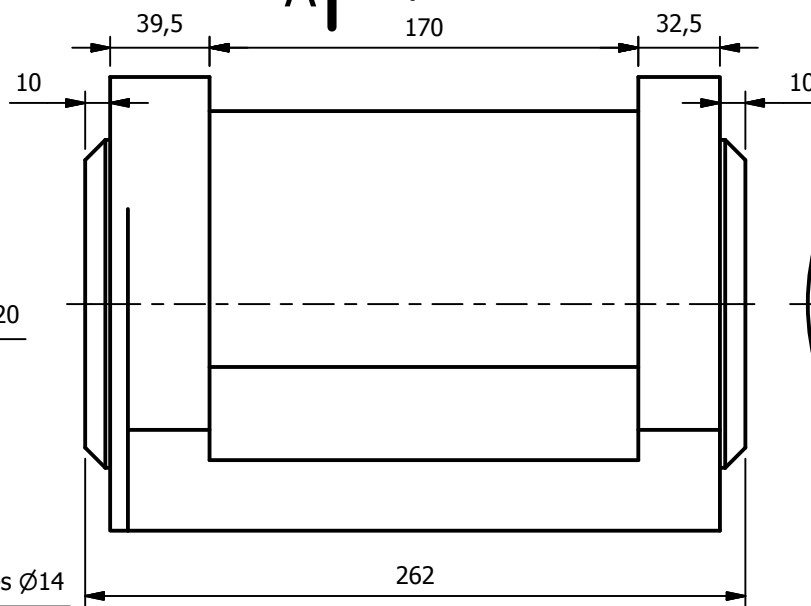

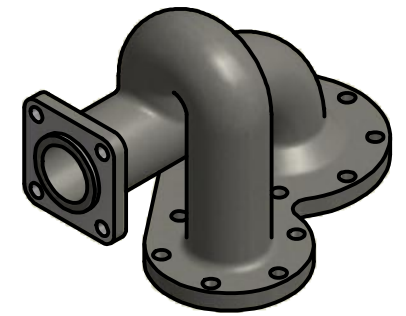
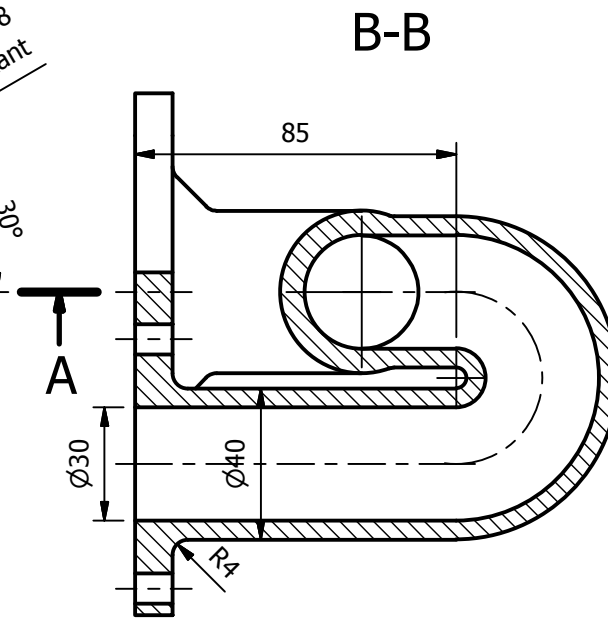
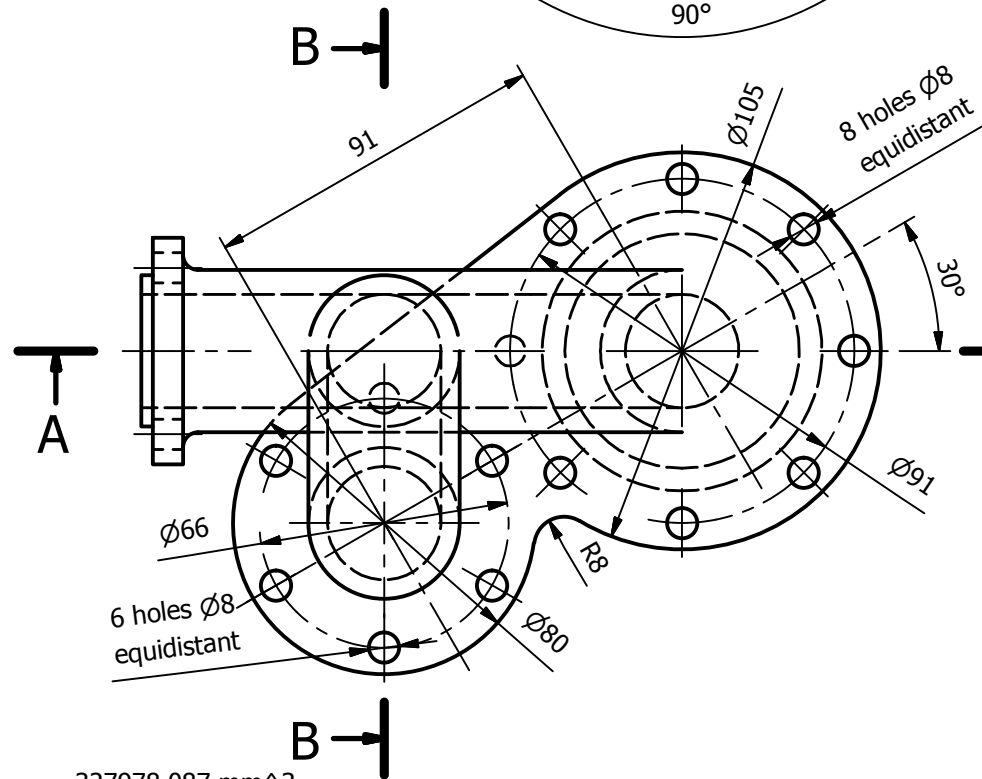
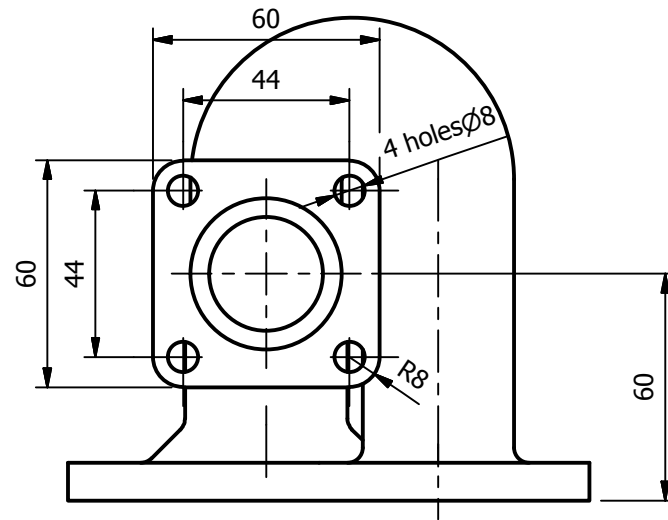
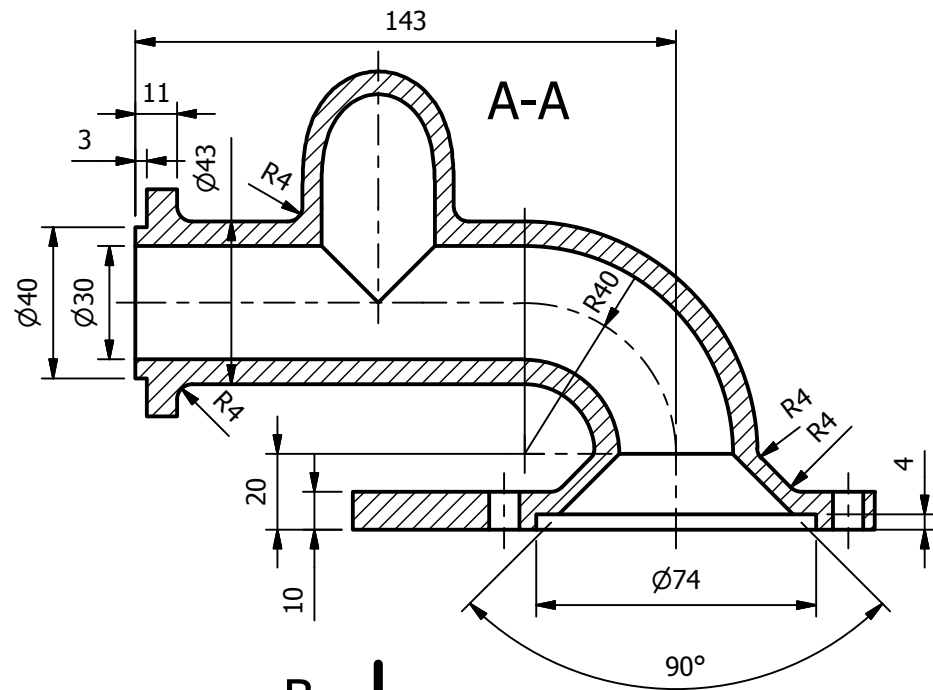

327978.087 mm³

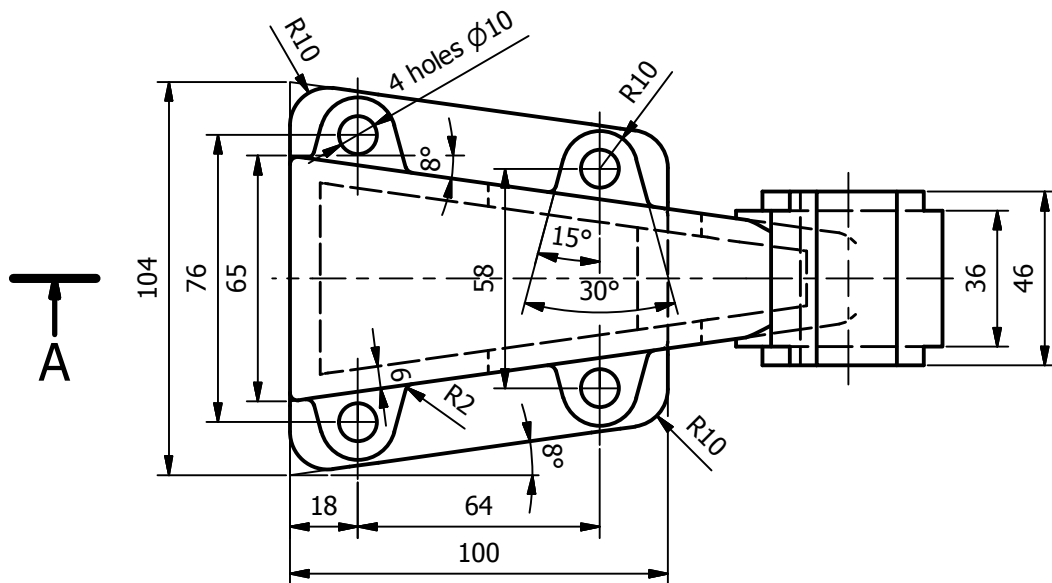
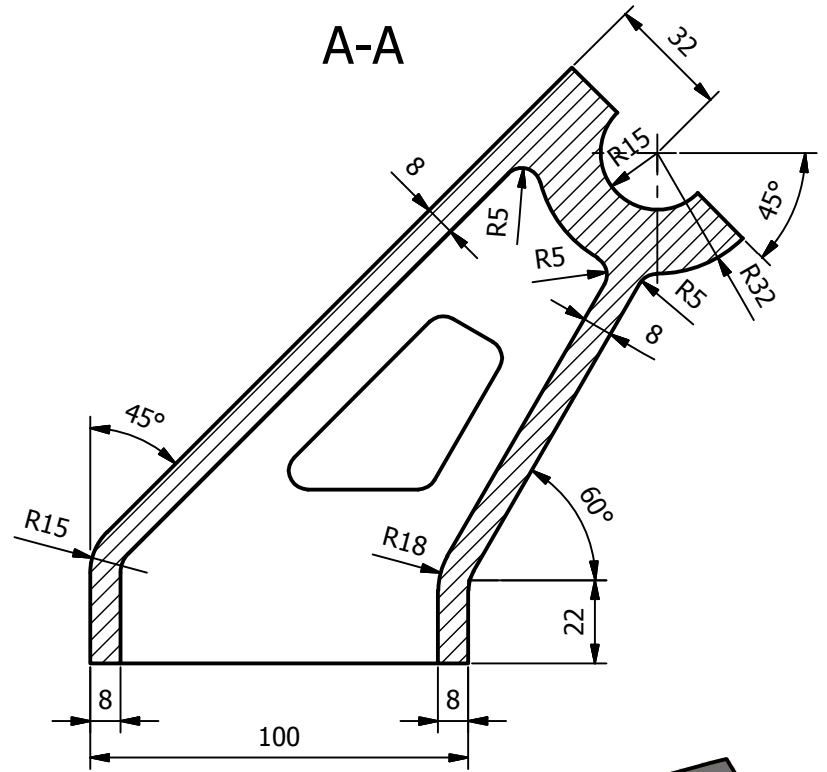
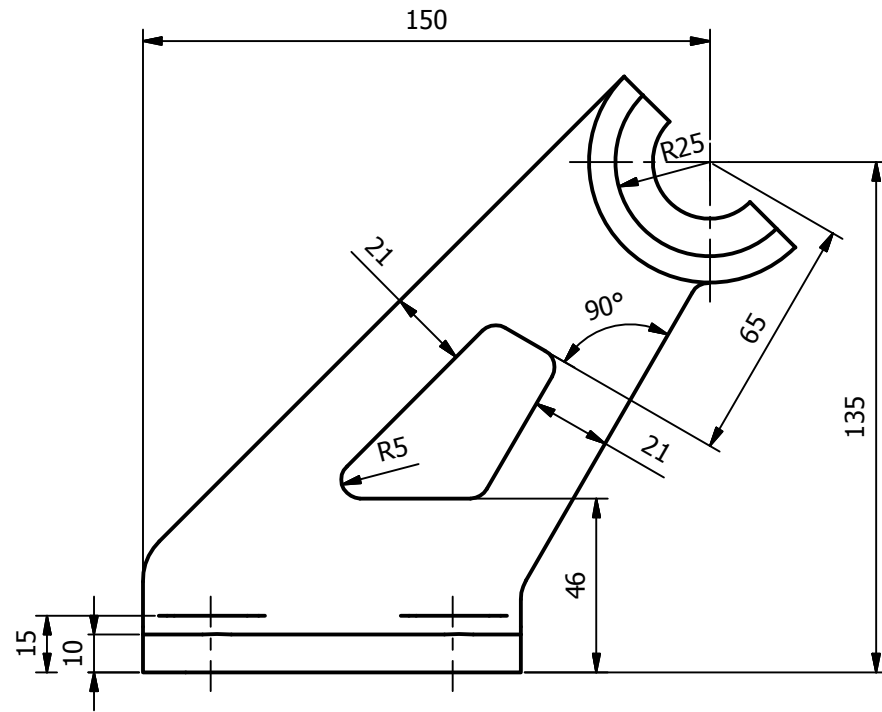

A

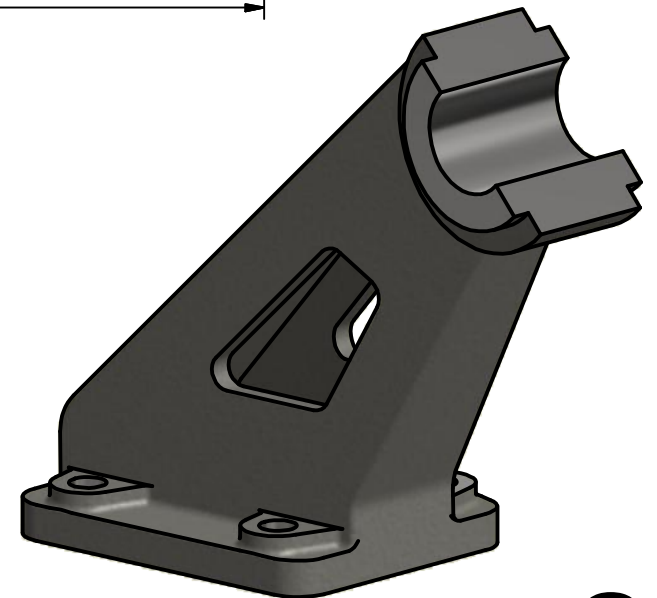

282809.640 mm³

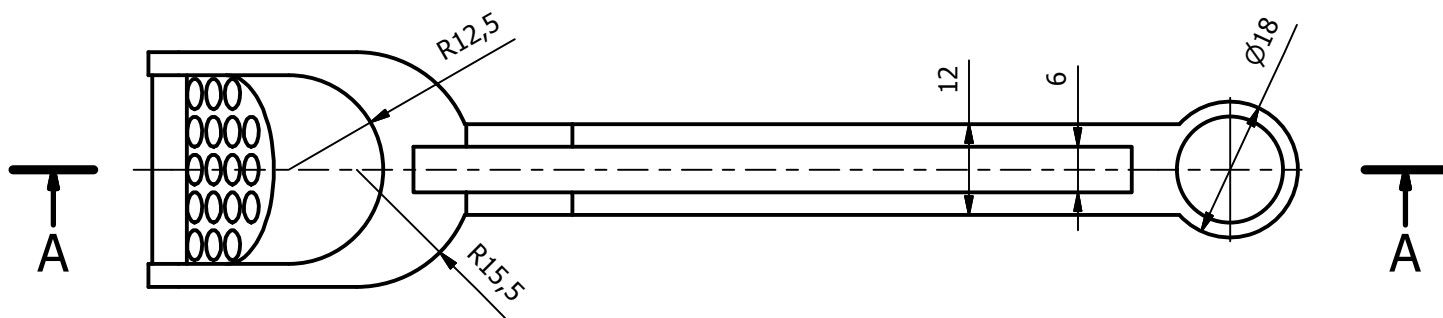
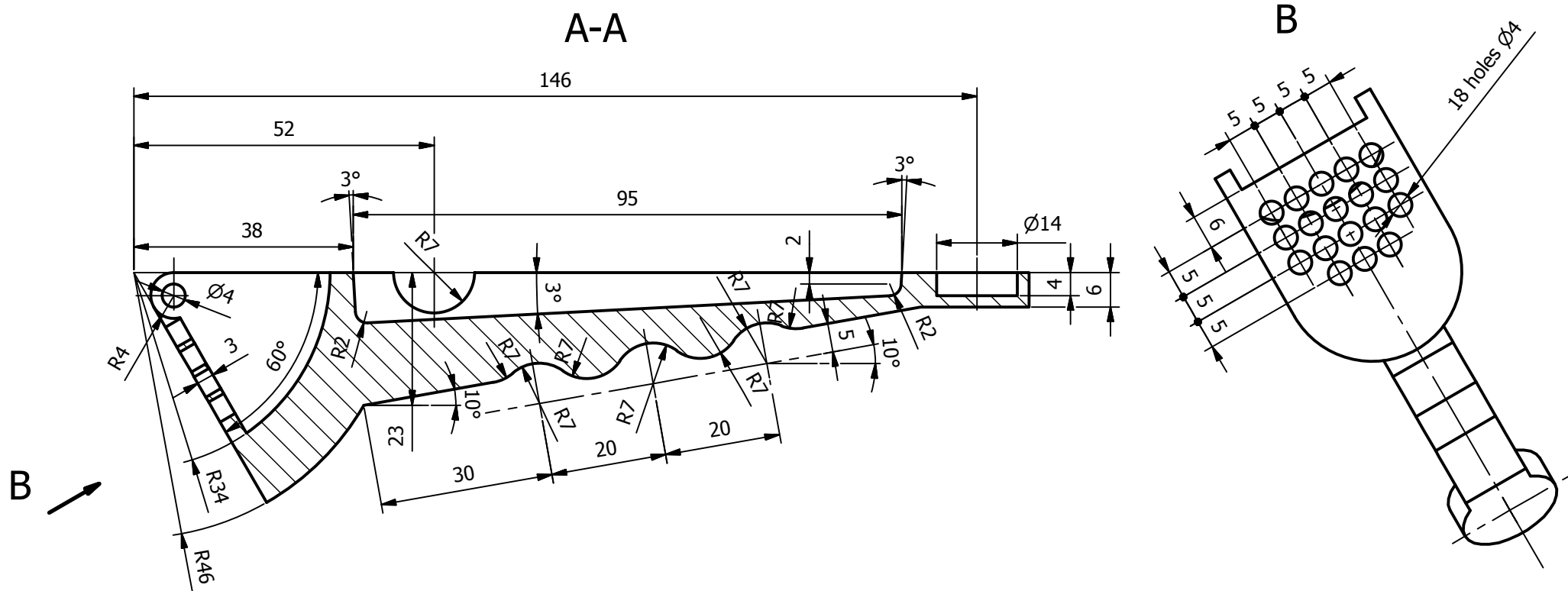

30158.883 mm³

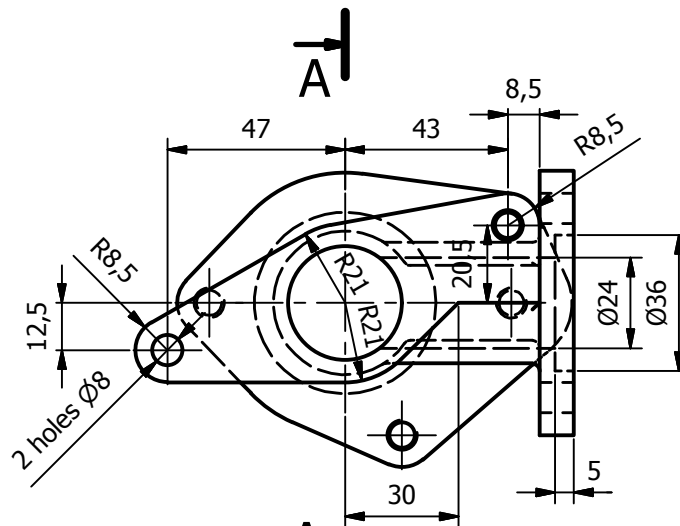
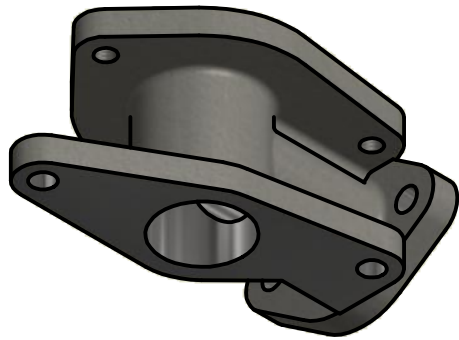

A-A

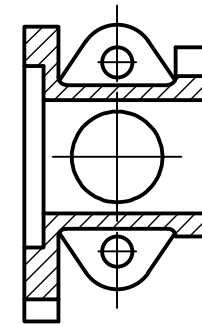

B-B

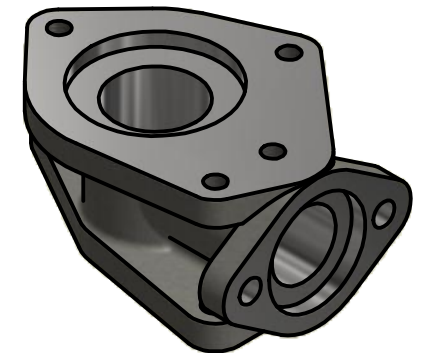
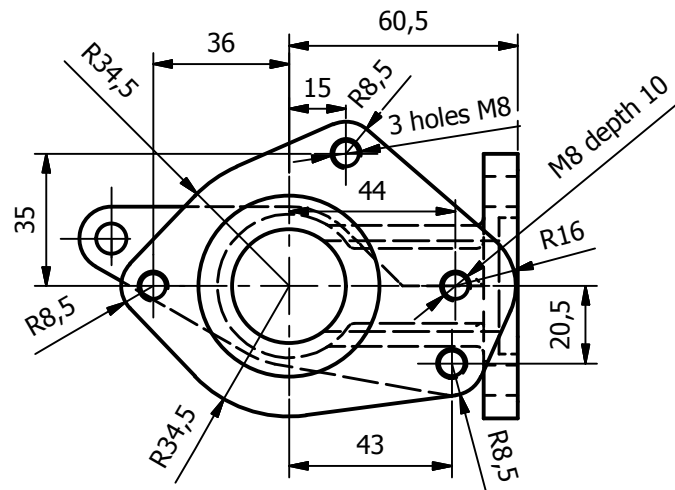
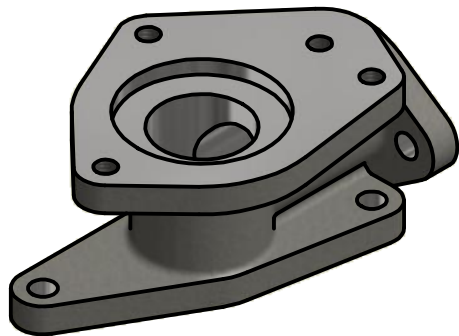
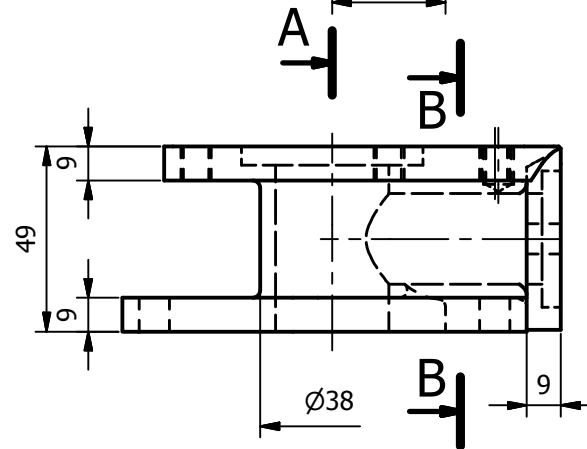
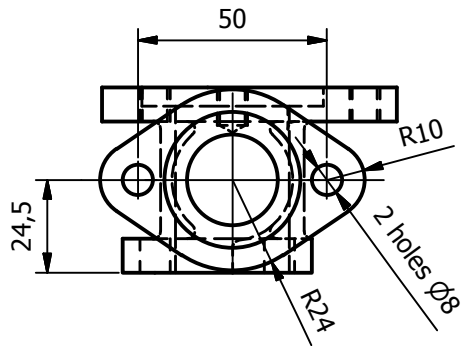
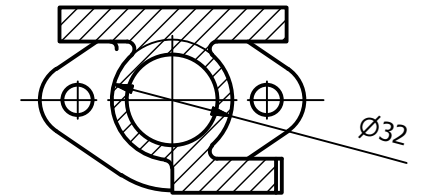

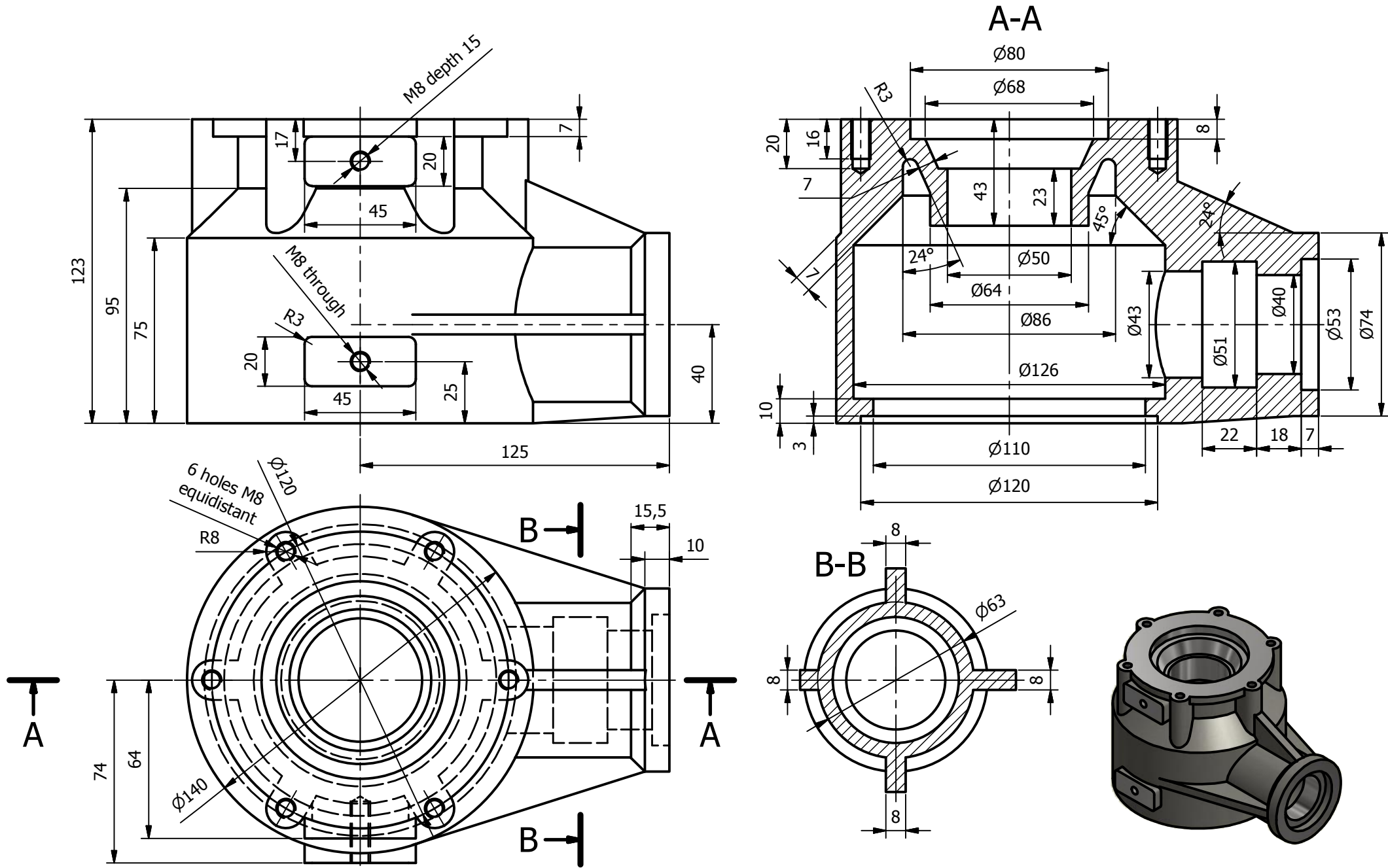

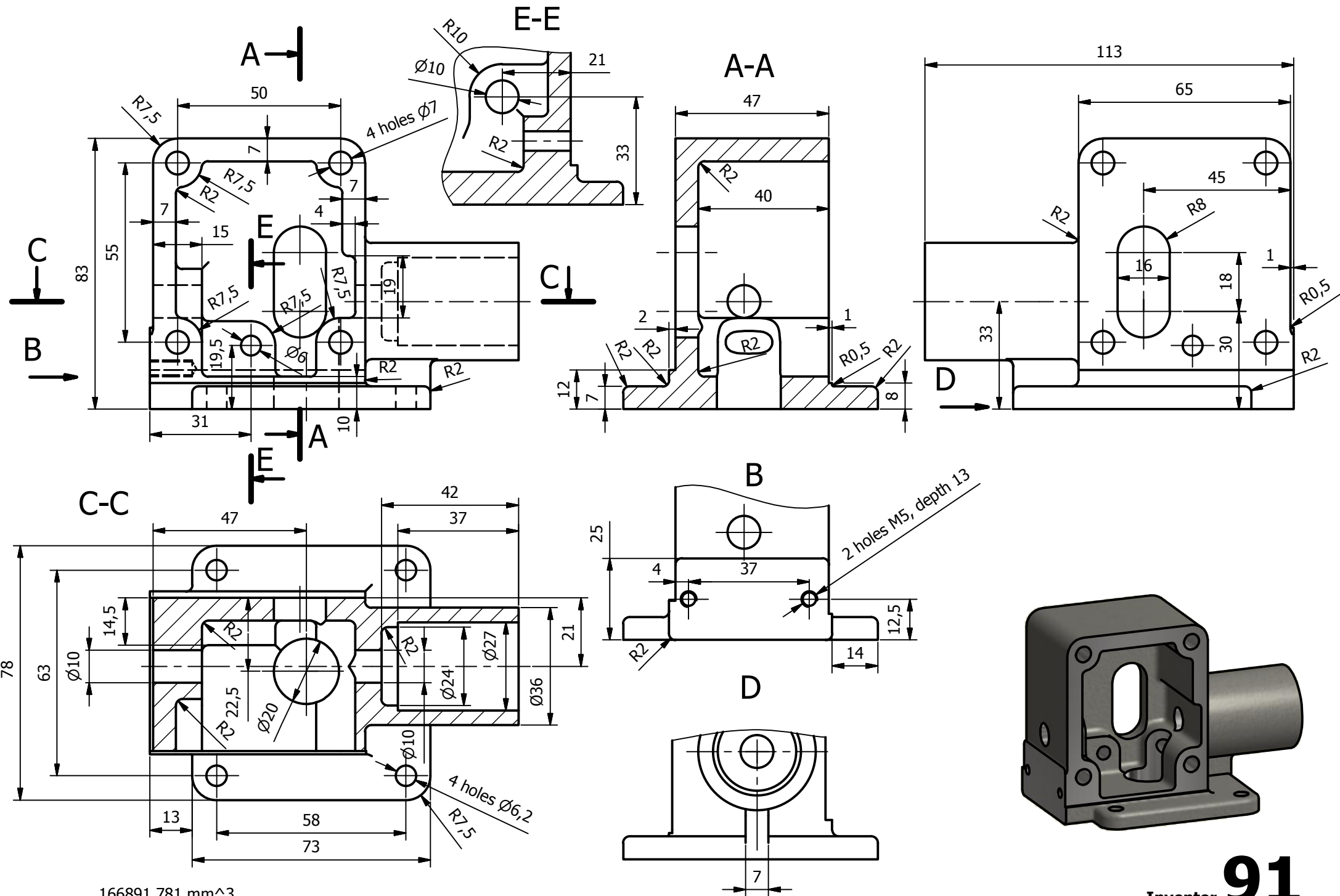

166891.781 mm³

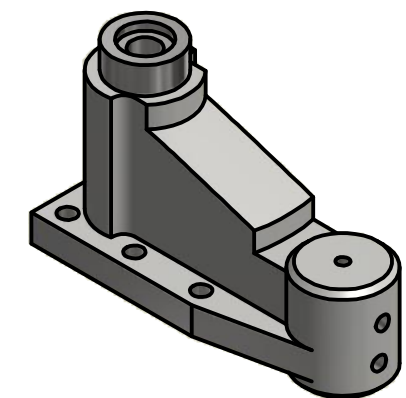
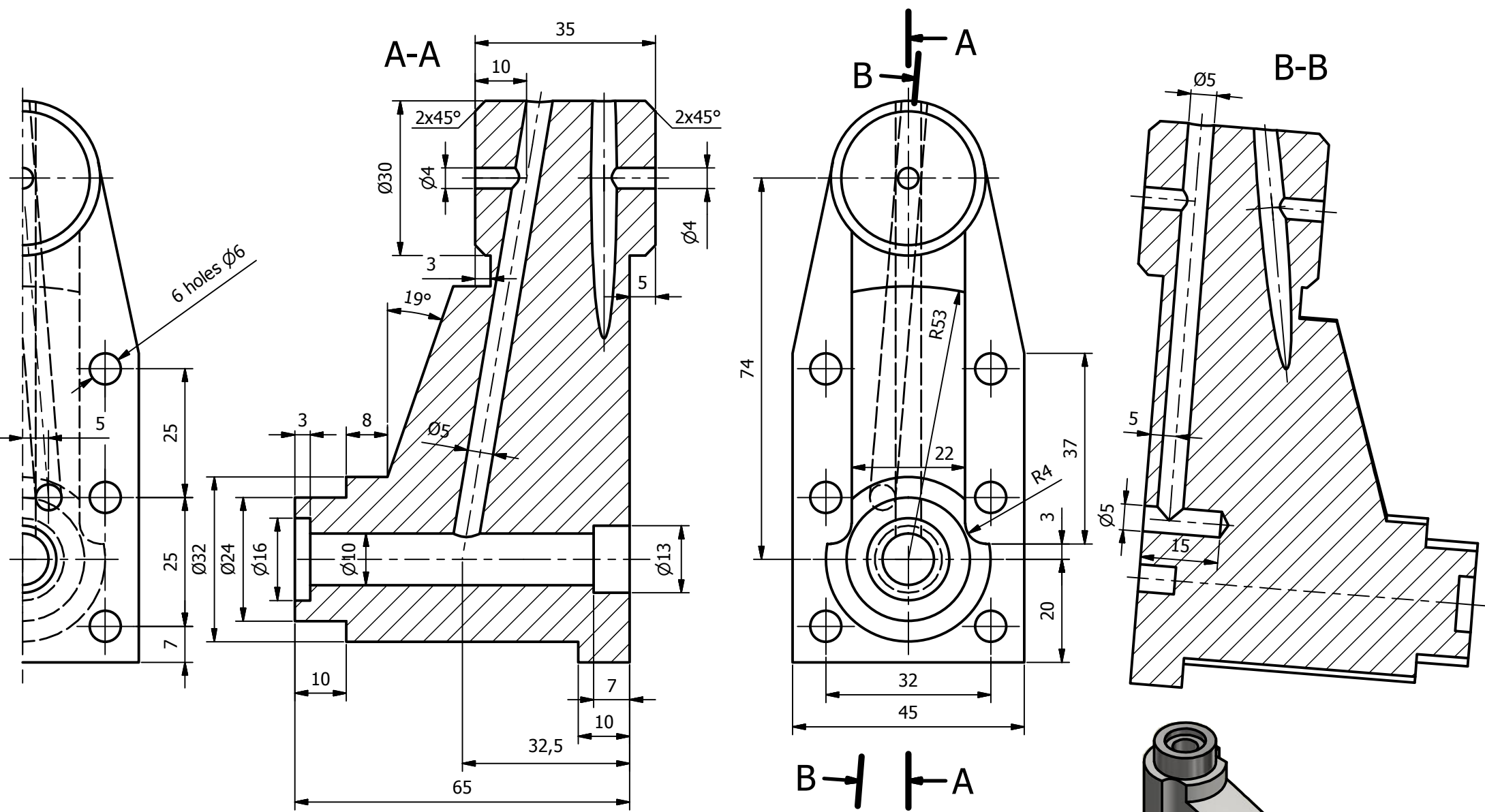

116853.807 mm³

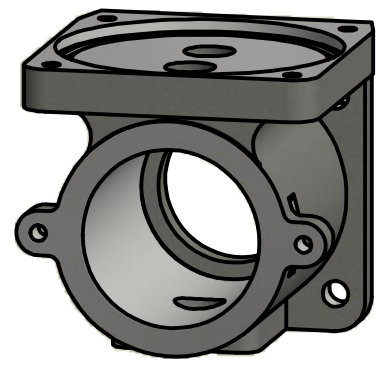
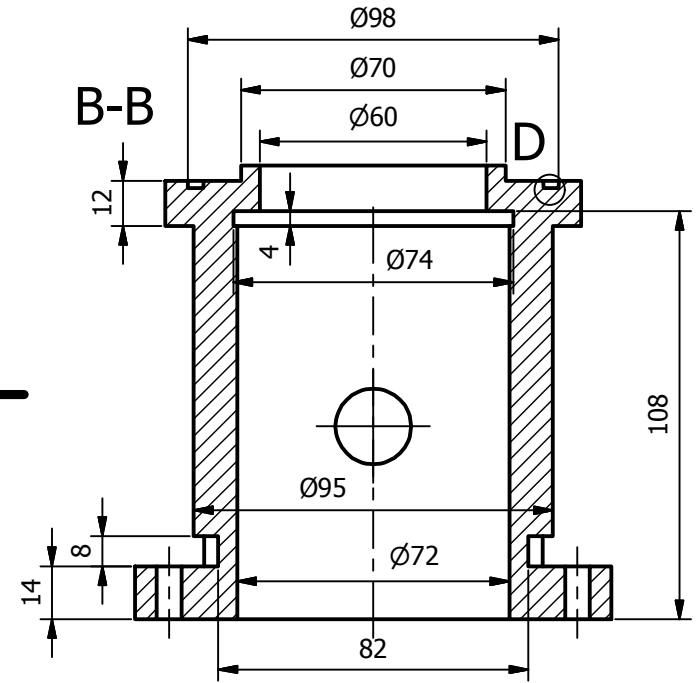
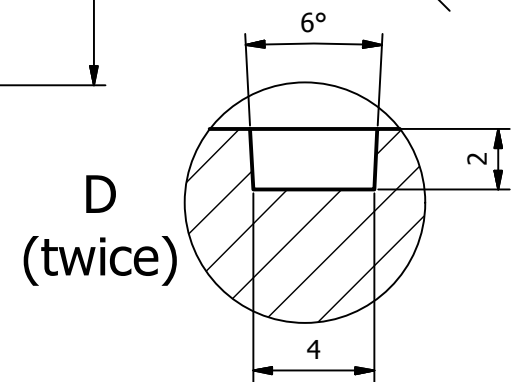
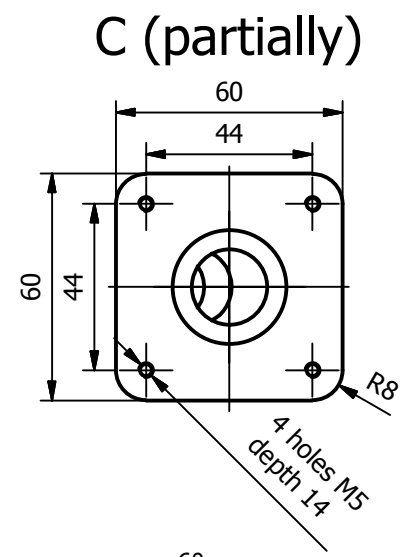
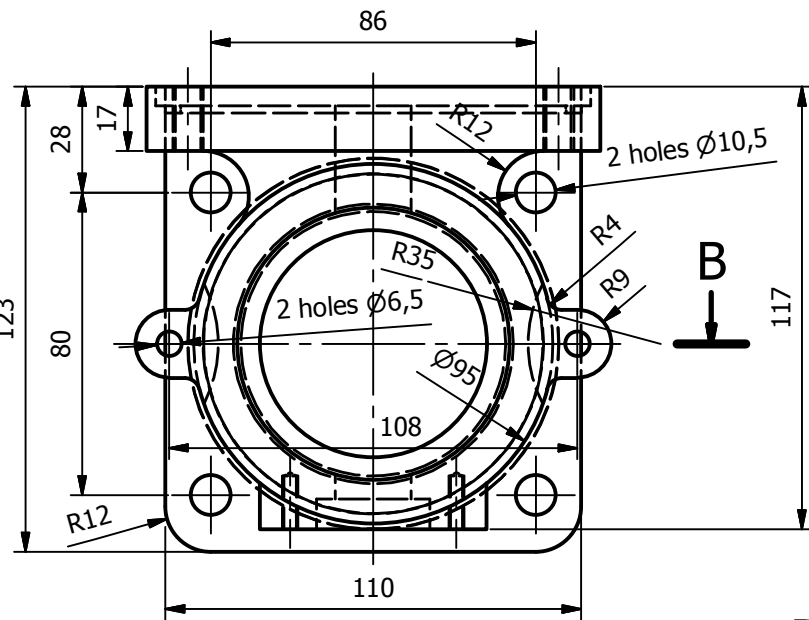
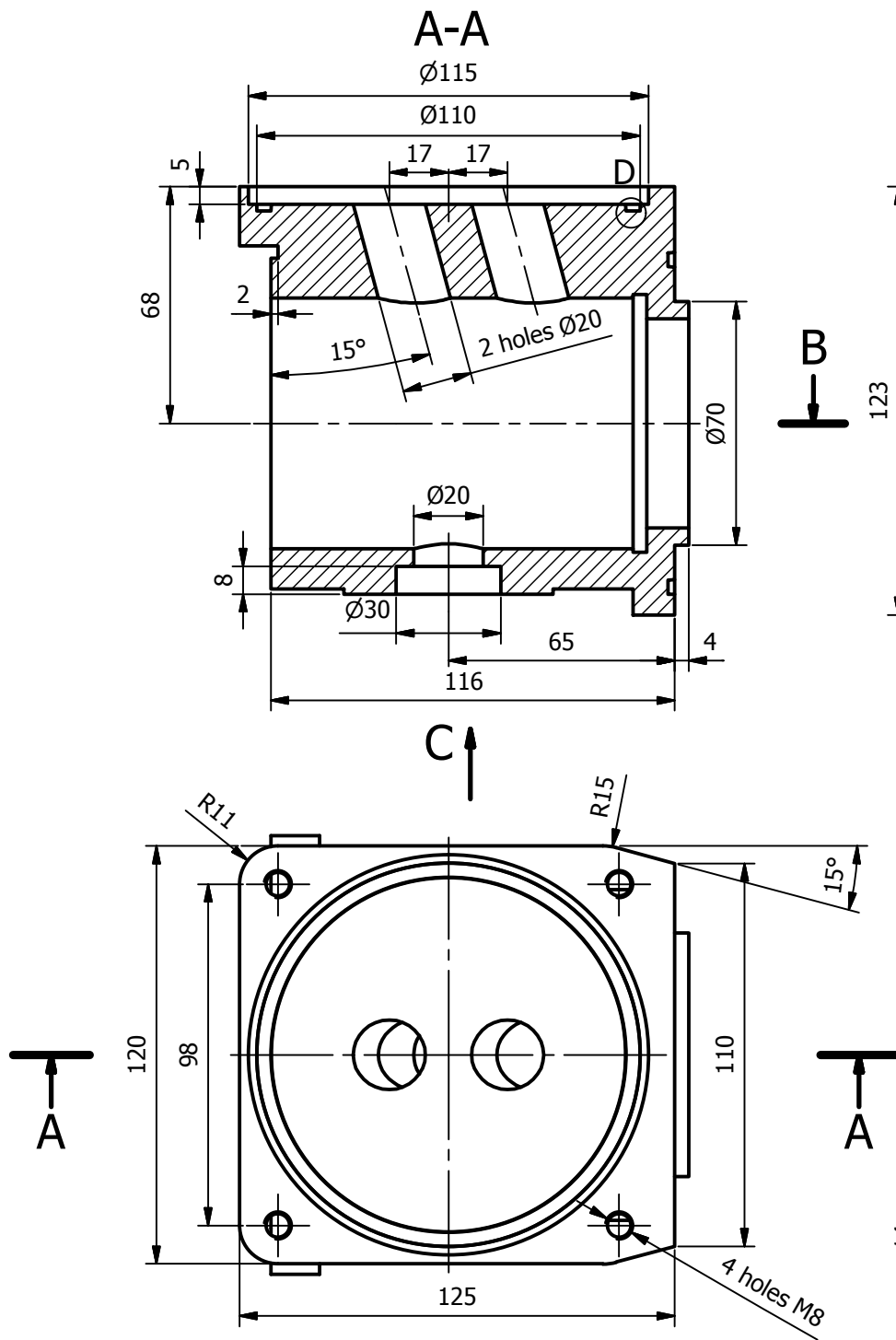

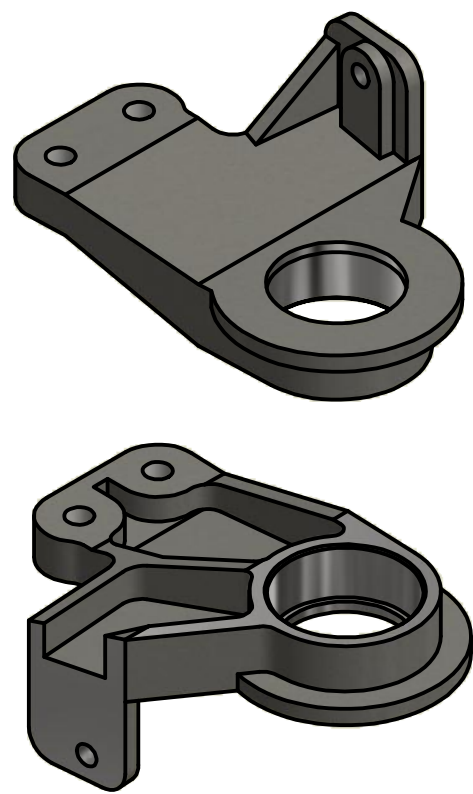
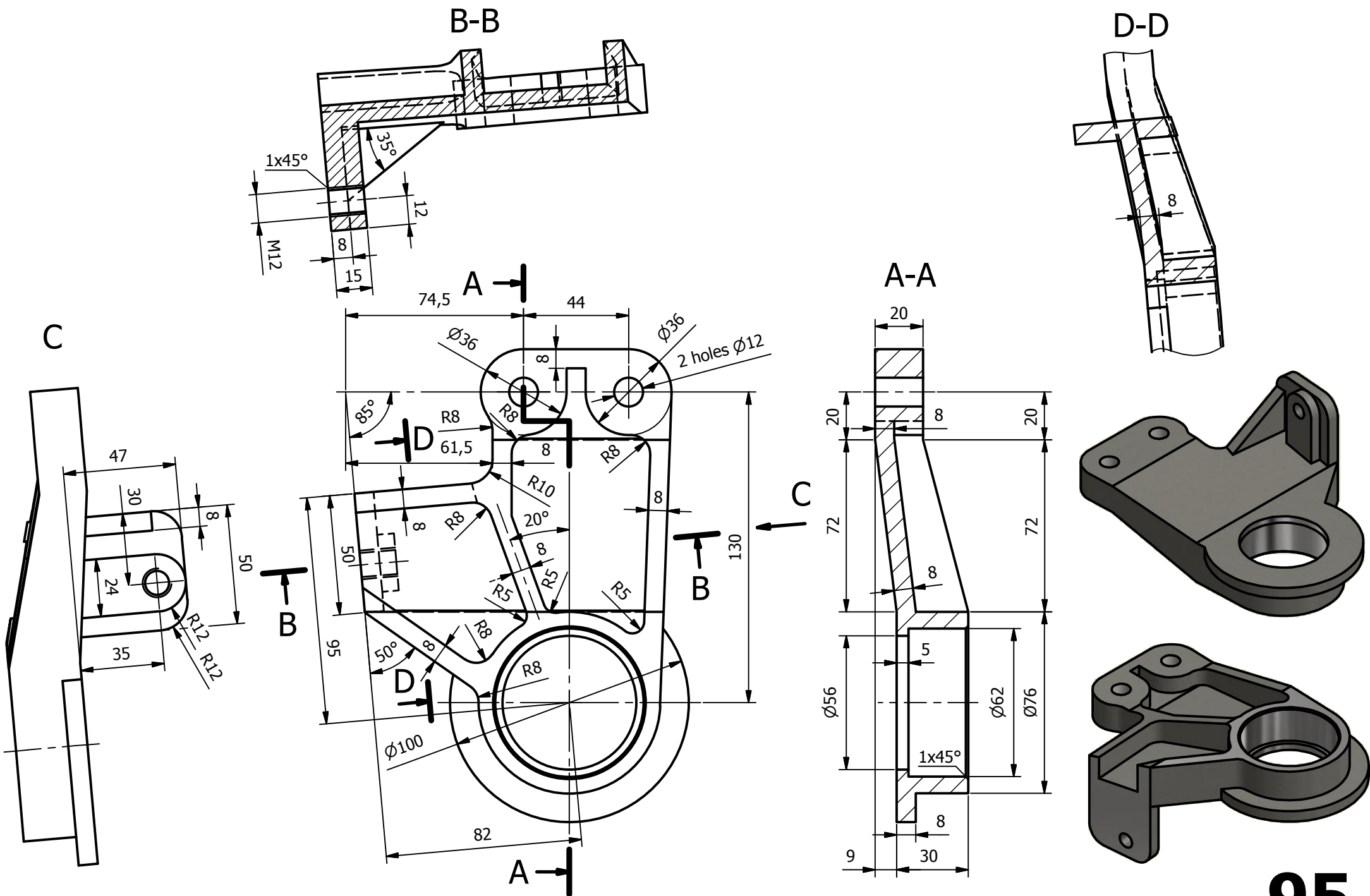

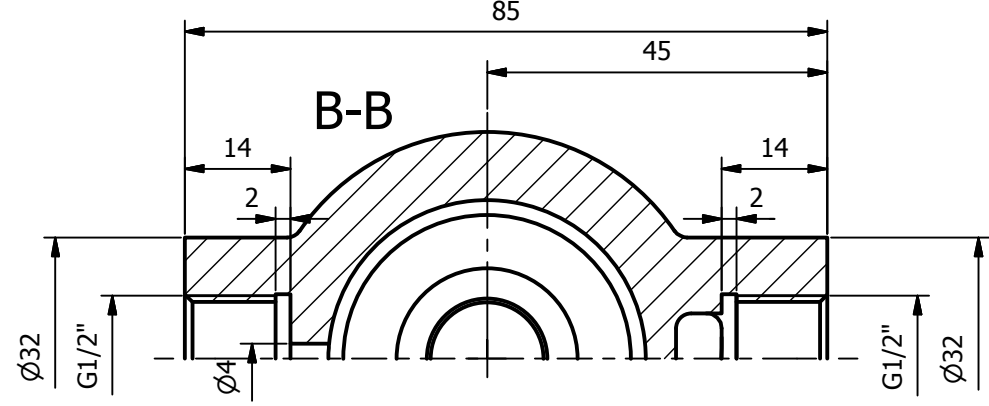
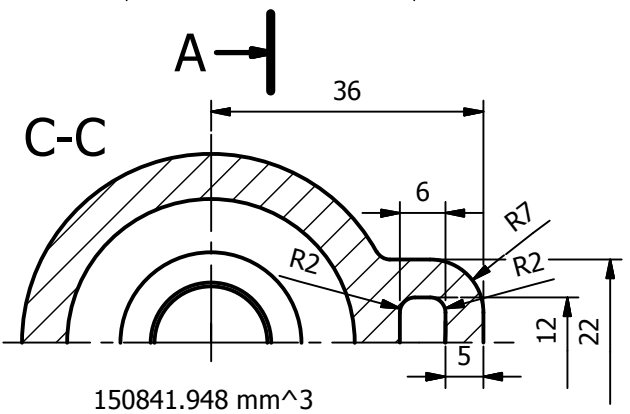
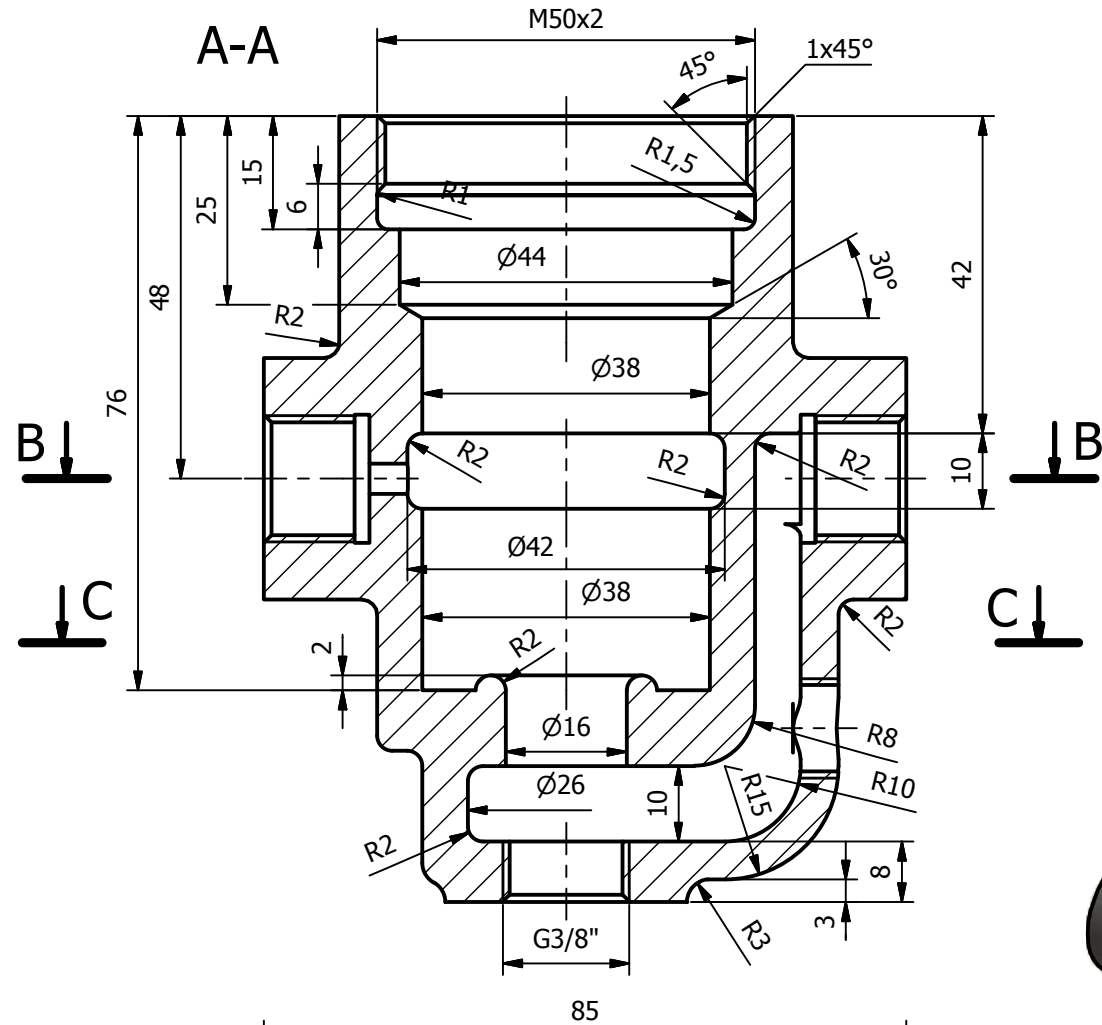
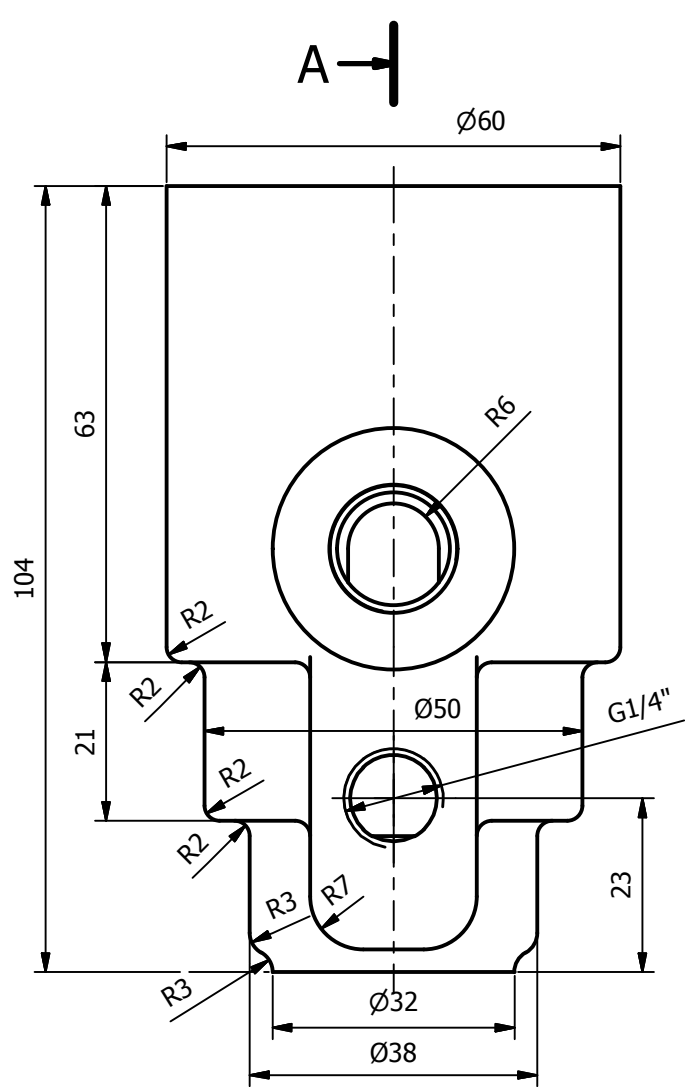

150841.948 mm³

