

AZ Closets
1267 S. Johnson Drive,
City Of Industry, CA 91745

PRSRT MKTG
U.S. POSTAGE
PAID
INDUSTRY, CA
PERMIT NO.1721



CLOSET
Closet & Wardrobe Doors.

Sliding Sanctuary
subtle style.

Collection I
2025

HUGE SELECTION OF DOORS AND SUPPLIES

RAPID LEAD TIMES!

All our products are made & packaged here
in the USA!

We ship across the United States!



BULK DEALS AVAILABLE

1-626-554-3380
info@az-closet.com





Hello!

Since its inception in 2022, AZ has been on a relentless journey to reshape the glass and hardware industry. From the very beginning, our vision has been clear: to not only meet the demands of the modern glazing world but to exceed them by pushing boundaries. We have committed ourselves to continuous improvement, tirelessly innovating new technologies that redefine industry standards. Whether it's enhancing logistics, refining pricing structures, or elevating the quality of existing solutions, we strive to deliver excellence in every aspect of our work.

At the heart of AZ lies an unwavering pride in the craftsmanship of our products. Every custom-fabricated item is a testament to the skill and dedication of our team, who pour their expertise and passion into creating solutions that stand the test of time. We believe that exceptional products stem from a foundation of precision, innovation, and an uncompromising commitment to quality.

As we look to the future, AZ is taking bold steps to usher in a new generation of hardware solutions. Founded by glaziers, for glaziers, we understand the unique challenges and aspirations of those in the industry. This deep-rooted connection drives our mission to not only serve but empower the professionals who shape the spaces we live and work in.

Through innovation, craftsmanship, and an enduring dedication to progress, AZ is building a legacy of trust and excellence—one pane, one product, and one innovation at a time.



MATERIALS EDGE
VUE CELL
ARC
SHIFT

Table of CONTENT.

Explore our comprehensive catalog to discover a wide range of offerings. If you are unable to find specific information or items, please don't hesitate to reach out to our hotline or contact our support desk for further assistance. We are here to help.

MATERIALS - Wood

Professional Grade



WF393
Concrete Groovz

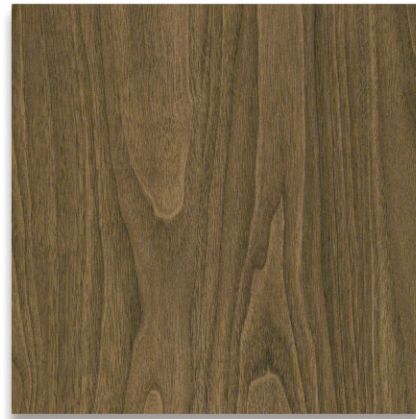

WF442
Chique



WF394
Arctic Groovz



WF462
Wallowa Pine

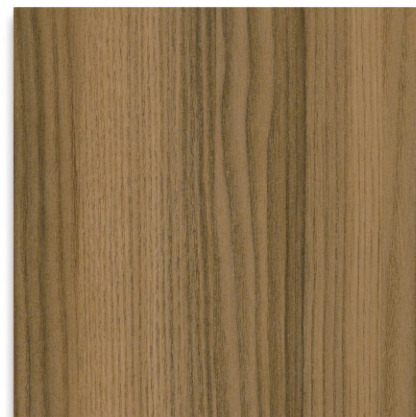

WF452
Karuna Ash

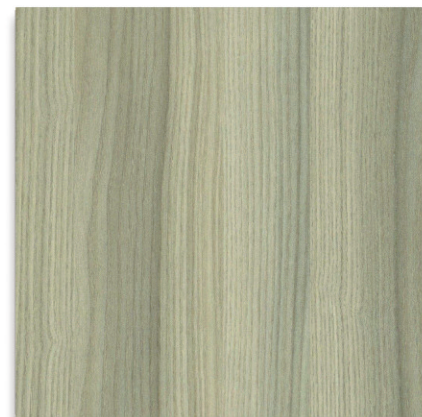

WF449
Sarek Ash



WF459
Abiqua Pine



WF444
Tumalo Pine

Need something custom or something that you don't see here? Contact us!

MATERIALS - Glass

Professional Grade

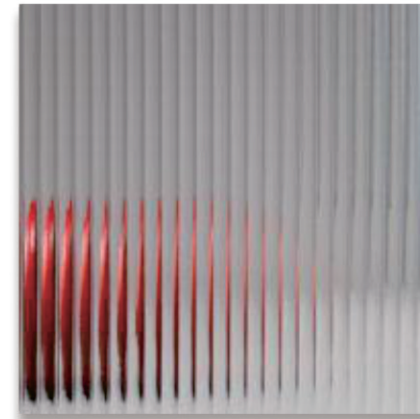

KW627
Reeded Glass

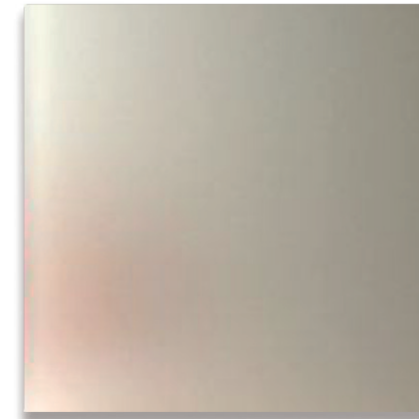

KW420
Acid Etched Glass



KW230
Frosted Glass

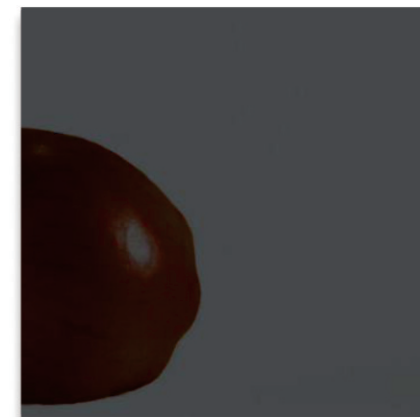

KW221
Grey Glass



KW120
Mirror



KW660
P516 Glass

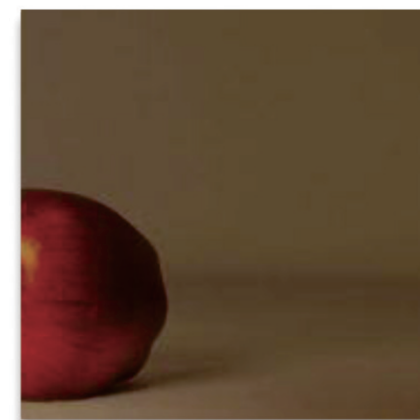

KW230
Bronze Glass



KW550
White Glass

Need something custom or something that you don't see here? Contact us!

VUE

The "3 Grid" Style

Elevate your space with a design that's as balanced as it is beautiful. Each door is divided into three horizontal panels, creating an understated symmetry that draws the eye and subtly amplifies the feeling of openness. Clean lines and a pared-back aesthetic keep the look modern and refined, while the proportional sections offer just enough visual interest to make a statement. Perfect harmony of sleek form and functional storage.

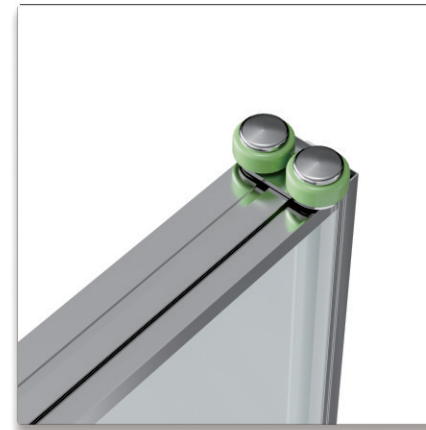

Frame Finishes
Brite Anodized
Dark Bronze

ARC

The "6 Grid" Style

Make a statement with wide, alternating horizontal bands that bring a striking sense of rhythm to your space. The contrasting tones create depth and dimension, all while visually expanding the room. Clean lines and balanced proportions give it a distinctly modern vibe, but the subtle interplay of color ensures it remains elegant and refined. Perfect for those who want a closet door that merges contemporary style with practical functionality, transforming any area into a sophisticated sanctuary.

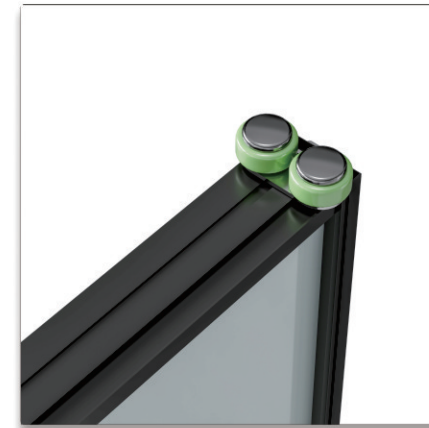

Frame Finishes
Brite Anodized
Dark Bronze



SHIFT

The "4 Grid" Style

By dividing each panel into multiple horizontal rows, we transform small spaces into generous, open havens. Clean lines and balanced sections create a modern aesthetic that maximizes both storage and style.

Choose and changeable with a plentiful of materials, boards and glass.

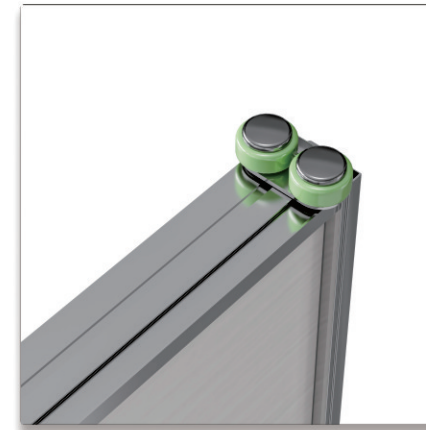

Frame Finishes
Brite Anodized
Dark Bronze

EDGE

The "5 Grid" Style

Experience the perfect balance of nature and modernity. Wide horizontal bands in a rich, dark finish contrast against the warm woodgrain panels, lending a sense of depth and dimension to your space. The earthy textures bring inviting warmth, while the bold stripes add a sleek, contemporary edge. It's a harmonious blend of organic charm and urban sophistication—ideal for creating a refined, yet welcoming ambiance.

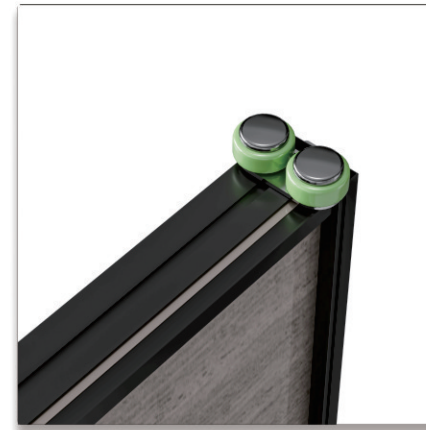

Frame Finishes
Brite Anodized
Dark Bronze

CELL

The "Acid Etched" Style

Balancing between support and structural architect. We present the etched glass style, where the entire face is divided into 4 faces of acid-etched glass, allowing a close view and some-what view of the content inside the closet.

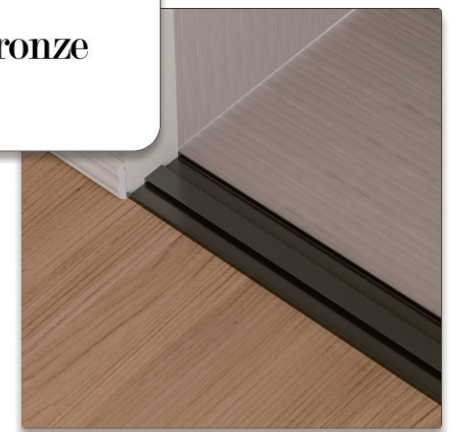
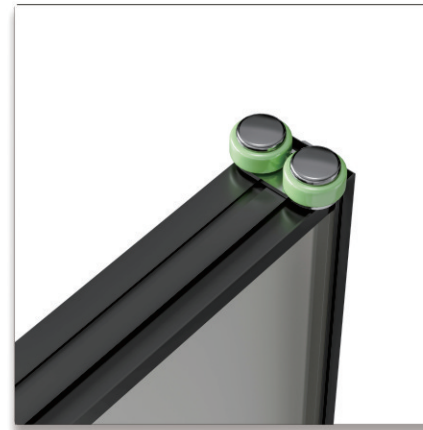

Frame Finishes
Brite Anodized
Dark Bronze