

Go Green!

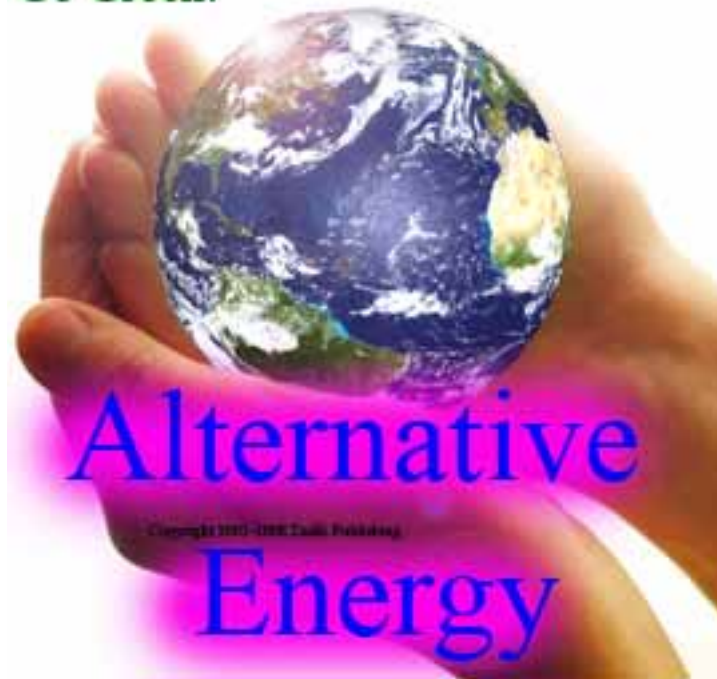

How To Make A Solar Cell. Nano Crystalline Solar Cell Research Patents

Copyright 2002-2008 Zadik Publishing.com

[Visit Us On The Internet...](#)

www.zadikpublishing.com

How To Build A Solar Panel.

Copyright 2001 Zadik Publishing, All rights reserved.



My Solar Panels Mounted on old C-band Satellite Dish Pole using Actuator Tracking.

Contents

1. Estimating Your Needs.
2. Power Consumption Guide.
3. Electric Motor Consumption.
4. Sun Tracking.
5. How To Use A Multimeter.
6. Wiring Up The Solar Array.
7. Wiring The Panels and Battery.
8. Mounting Solar Panels.
9. Choosing An Inverter.
10. Panel Assembly
11. From Panel to Outlet.

1. Estimating Your Needs

You need to have a good idea of how much electricity is required before you can decide on the appropriate size of your solar array, and the size of cables and battery bank.

There are Three Simple Steps to determine the average daily load:

1. Select which lights and appliances will be used.
2. Find out how many amps or watts each consumes.
3. Work out how many hours each day (on average) each appliance will be used.

Since the size of your battery bank is rated in terms of amp-hours and the meter on your distribution/meter box measures the power coming in from your charging system in amps, it makes sense to convert watts to amps. I will give you some examples:

1. You have a 12 volt portable radio and cassette player that has a label on the back that says 12 volts, 0.2 amps. You don't need to calculate anything for this as the current draw is already given in amps at 12 volts.
2. You want to use a 12 volt 20 watt light bulb. To work out the amps you just divide 20 watts by 12 volts and you get 1.67 amps.
3. You have a 240 volt juice extractor rated at 300 watts. If you have a solid state inverter rated at 400 watts you can expect 85% efficiency. So to work out the amps at 12 volts you divide 300 watts by 12 volts and you get 25 amps; on top of that you have the inverter efficiency to add to that figure. Divide 25 by 0.85 (85%) and you get about 30 amps.
4. You have a 240 volt color TV that doesn't have a watts rating but does give an amps rating. The figures it gives are 240 volts, 50 hertz, 0.3 amps. This amps usage figure is the power consumption at 240 volts. Since amps times volts equals watts, this works out at 72 watts (240 times 0.3). Now to work out the amps at 12 volts you divide 72 watts by 12 volts and you get 6 amps. If you run this off the same 400 watt inverter you can only expect 70% efficiency (refer to inverter data supplied by your dealer). Divide 6 amps by 0.7 (70%) and you get 8.5 amps.

Now to give you an example of working out the daily power consumption:

1. You listen to either the radio or cassette player for 6 hours each day. The 12 volt system you have is rated at 0.2 amps at 12 volts. Multiply the amps by the hours and you get the result of 1.2 amp-hours per day.

2. You use three 20 watt 12 volt lights for about four hours each night. The power consumption for each light we worked out earlier to be 1.67 amps. So for three lights we calculate a current draw of 5 amps. So to calculate the power consumption we multiply 5 amps by 4 hours to get the result of 20 amp-hours per day.
3. You use a juice extractor for 10 minutes each day. I have already calculated that the inverter draws 30 amps when the juice extractor is running. Divide 30 by 6 (because you use the juicer for 1/6th of an hour) and you get a result of about 5 amp-hours per day.
4. You watch the color TV for about 2 hours each night. I estimated before that the inverter draws about 8.5 amps when the color TV is on. Multiply 8.5 by 2 and you get 17 amp-hours per day.

Here are those figures in tabulated form:

Appliance	Amps	Hours Used	Amp-hours
radio/cassette	0.20	6.00	1.20
3 lights	5.00	4.00	20.00
juicer	30.00	0.17	5.00
color TV	8.50	2.00	17.00
TOTAL			43.2

Now, You can design your system for your specific needs, easy wasn't it

2. Power Consumption.

POWER CONSUMPTION GUIDE (240V)		
APPLIANCES	START	WATTS
Adding Machine	-	8
Air Conditioner	-	1200 - 2500
(evaporative - mobile)	-	275 - 1000
Alarm/security system	-	6
Blanket (under)	-	60 - 120
Blanket (over)	-	150 - 350

Can Opener	-	100
Cassette Deck	-	30
CB (receiving)	-	10
Cellular phone (on standby)	-	20
Circular Saw (small)	-	1350
Clothes Drier	-	2400
Coffee Grinder	-	75
Coffee Percolator	-	540
Compact Disc Player	-	30
Computer (Laptop or Notebook)	-	15 - 25
Computer (Desktop with Hi-Res Color Screen)	-	200
Computer Printer (see Printer below)	-	80
Disposal Unit	-	650
Drill	-	250 - 500
Dishwasher	-	1000 - 3000
Domestic Water Pump	2000	500
Electric Toothbrush (charging stand)	-	6
Exhaust Fan	-	40 - 75
Fan	-	20 - 100
Fax (standby)	-	10
Fax (printing)	-	120
Food Mixer & Whiz	-	500
Floor Polisher	-	350
Freezer	2500	500
Fry pan	-	1400
Hair Drier	-	350 - 800
Health Lamp	-	150 - 800
Heater	-	500 - 3000
Hot water Service	-	2500 - 5000
Infra-red Grill	-	2000
Iron	-	1250
Juicer/Blender	-	350
Kettle or Jug	-	1600 - 3000
Microwave oven	-	600 - 1000
Printer (Ink Jet)	-	15 - 40

Printer (Dot Matrix)	-	80 - 200
Printer (Laser)	-	1200
Radio	-	15 - 60
Radiator	-	1000 - 2500
Record Player	-	75
Refrigerator	1500	300
Sewing Machine	-	60
Space Heater	-	2000
Stove	-	5000 - 10000
Television	-	60 - 200
Toaster	-	500 - 1500
Tumble Drier	-	2500
Typewriter	-	35
Vacuum Cleaner	-	700 - 1200
Video Recorder	-	17 50-
Washing Machine	2500	600
Welder - 140A	-	4000

NOTE: These figures are a guide only and the wattage ratings may vary greatly from one appliance to another, just check each appliance for actual draw.

3. Electric Motor Consumption

Electric Motors - Starting Current				
		Type of Motor		
-	Watts	Induction	Capacitor	Split-Phase
1/6 hp	275	600	850	2050
1/4 hp	400	850	1050	2400
1/3 hp	450	975	1350	2700
1/2 hp	600	1300	1800	3600
1 hp	1100	1900	2600	-

NOTE: Brush type motors without a load do not require a significantly higher starting current than their continuous current rating.

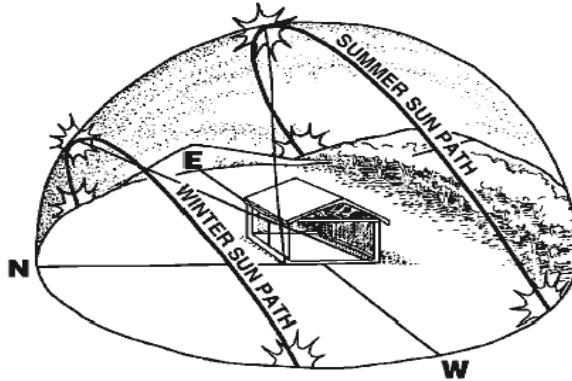

4. Sun Tracking...YES it's worth it...So Do It!

Whether tracking is really worth the expense depends on a number of factors:

1. The cost of the Tracker.
2. The extra energy gained by tracking. It is not enough to say that the panel(s) may put out twice as much power under given circumstances. It is the accumulated amp-hours (amps times hours) over the course of the day that determines your daily gain.
3. The gain is not consistent throughout the year. The greatest gain is usually in summer when the hours between sunrise and sunset are the longest and the sun sweeps its greatest arc across the sky (refer to above picture). If this potential for an increased gain in summer also coincides with a wet season or consistently overcast weather then the actual gain may be very little or nothing at all.

In fact, if you check (by monitoring) you will find that the horizontal (flat mounting) panels would frequently exhibit better performance patterns than the panels on fixed frames tilted to the north.

This is because on mildly overcast days the sunlight is scattered and the best results on such days are often when the solar panels are facing straight up and getting maximum benefit of the diffused light rather than attempting to pick up the direct sunlight.

4. The gain is also dependent on latitude. At increased latitudes the sun's arc across the sky in summer is also increased but in winter it is decreased. The following table shows the daylight hours (between sunrise and sunset)

Latitude	10°	15°	20°	25°	30°	35°	40°	45°
Summer	12.71	13.02	13.34	13.70	14.08	14.52	15.02	15.62
Winter	11.54	11.24	10.92	10.58	10.21	9.80	9.33	8.76

5. Solar energy usually has its greatest strength in the middle of the day and often the greatest cloud cover is in the mornings and evenings. The energy from the sun has to penetrate through the greatest depth of atmosphere at the horizon.
6. Your immediate environment and your geographic location may play a major role in the hours of direct sunlight (without shading) that your panels may receive. Nearby mountains, hills, trees, tall buildings etc may considerably reduce the number of hours of direct sunshine that your panels receive.

NOTE; Shadow throwing objects tend to have their greatest effect on a solar panel site when the sun is lowest in the sky.

Even the smallest amount of shading reduces panel output significantly. By monitoring your system, you may get an idea of the advantage in tracking the sun for your area by using the figures for a location of similar latitude and similar weather conditions to yours.

7. After having determined how much gain you could expect in mid summer and mid winter you may find that you get the most benefit when you least need it. An automatic solar tracking system usually costs more than a 75W solar panel (unless you build one yourself). Unless your loads are predominantly summer loads (eg: fridge, freezer, space cooling, pumping) and you already have at least 8 solar panels, you may be better off with another solar panel. An extra solar panel gives greater benefit in mid winter when there is the greatest demand for night time lighting and entertainment. If you need more power in winter for lighting and entertainment because of the shorter daylight hours then an extra solar panel may be money better spent than having a tracking device. But both is best...if you can.

Seasonal Adjustments?

The seasonal variations in the sun's angle are 23°15' added to latitude at the winter solstice (either 21 or 22 June in the southern hemisphere) and 23°15' subtracted from latitude at the summer solstice (either 21 or 22 December). By monitoring you may get an idea of the advantage in seasonally adjusting (in this case month by month) the solar array for your area by using the figures for a location of similar latitude and similar weather conditions to yours. A simple system where you

manually change the angle a few times per year would not involve much cost or effort but also gives you less gain than an automatic solar tracker.

Use of Reflectors

By having reflectors to increase the amount of light falling onto the panels, you may be able to increase the output of a solar panel. Unfortunately this approach may have the undesirable effect of increasing the temperature of the solar panel. As temperature increases above 25°C the nominal voltage of the panel increases. If the temperature of the panel is increased to 50°C the open circuit voltage (OCV) may be decreased by as much as 2 volts (for a 12 volt panel). If the panel happens to be a self-regulating panel such a voltage drop may have the undesirable effect of the panel ceasing to charge the battery altogether. You must also be careful that these reflectors don't have the reverse effect by shading the panel at any time. This would best be insured by combining both tracker and reflectors (and hoping that the tracker doesn't fail). In this instance seasonal adjustments a few times per year should be considered. This idea should only be contemplated if the potential for a temperature increase could be kept under control.

- **WARNING...Warranty on some panels is voided if reflectors are used.**

Grounding

Although it is not essential for the satisfactory operation of your system, the manufacturers of solar panels recommend that solar panels be grounded. Grounding with respect to photovoltaic installations serves several purposes:

1. it bleeds off static electric charge built up from wind and rain;
2. it is an integral part of lightning protection;
3. it provides fault protection, whereby any shorts or faults in circuitry will conduct enough current to ground to trip circuit breakers or fuses and allow fault detection. It is recommended that the earth stake should have a resistance to ground of 25 ohm or less. For adequate lightning protection, between 1 ohm and 5 ohm resistance to ground gives fairly reliable lightning protection. You may need to find an electrician with a multimeter to set up a good grounding for your system.

5. Using An Multimeter

Standard Multi Meter



A multimeter is a very valuable diagnostic tool which, because of its mobility and multi-function capability can provide information that a stationary distribution /meter box cannot. A multimeter is ideal for:

- ! Measuring Voltage of Individual Battery Cells
- ! Measuring Voltage Drop in Cable and Connectors
- ! Measuring Charge Rate of Individual Solar Panels
- ! Measuring Power Consumption of Individual Lights and Appliances
- ! Checking Calibration of Meters on the Control Board
- ! Checking Light Bulbs and Diodes

In the following few pages we will discuss how to measure volts and amps and calculate watts and amphours. We will also discuss how to test if a circuit is complete or not (continuity test).

Buying a Multimeter

It would be advisable to get a multimeter with either a 10 amp range or a 20 amp range. A DC clamp meter that can register several hundred amps would be particularly useful for measuring power consumption of inverters and the output of solar arrays and large battery chargers.

The voltage range of the multimeter would preferably be 0-15 volts for a 12 volt battery bank or 0-30 volts for a 24 volt battery bank. It would also be good to have a 0-3 volt range for testing individual cells of a lead-acid battery or a 0-2 volt range for testing individual cells of a NiCad battery. For our purposes the ohms scale isn't so important other than for testing continuity. It is also recommended to purchase your-self a set of insulated slip-on Alligator Clips.

If what you are attempting to measure is constantly fluctuating an analog meter (which has a needle pointing to a scale of numbers) is easier to read than a digital meter. For measuring the voltage of a battery bank and DC currents and voltages generally, a digital meter (which has an LCD display similar to the display of a calculator) is preferred.

DC Clamp Meter



HINTS

1. When using the meter, pay particular attention to polarities and check positive and negative points. The red lead connects to positive and the black lead to negative.
2. It is generally good practice to position one probe first (usually the negative probe), and get it secured with an alligator clip or by finger tightening a screw onto the probe before testing or probing with the other probe. This makes it easier to concentrate on only one probe.
3. If you are checking unknown currents and voltage, use highest range first, then next lower range, and so on until readings can be obtained.
4. For most accurate readings, keep the meter lying flat on a non-metallic surface. Also, use a range setting that result in a reading in the upper third of the meter scale.
5. With an analog meter, for exact readings, look at the scale from the point where the pointer and its reflection on the mirror behind the pointer come together; otherwise a reading error may result due to Parallax.

WARNINGS

1. Do not apply voltage to probes while the range switch is in current (amps) or ohms position. When using the clamp on a digital clamp meter, this is not a concern.
2. Testing AC wiring circuits can be dangerous. Never clamp on to a 'hot' wire (usually red or brown) since if you did so and then touched the other probe, you could receive an electric shock. For your own safety leave the AC diagnostics to a qualified electrician and just concentrate on the DC circuitry.

How to use a Multimeter

It is recommended to read the instruction manual of your multimeter before reading the following.

DC Voltage Measurement

Select the required DC voltage range (if in doubt start from the highest range and work your way down until a reading can be obtained) with the probes connected in parallel (+ve to +ve, -ve to -ve) to the points to be measured.

Open Circuit Voltage

Open Circuit voltage (OCV) is the terminal voltage of a battery while at rest. This means that there is no charge or discharge of that battery. OCV is the most meaningful voltage of a battery as this can indicate state of charge. Each cell of a fully charged lead-acid battery should have an OCV of around 2.1 volts. At 50% discharge the OCV will be about 2.0 volts per cell. At around 1.8 volts per cell or less the battery is considered discharged.

It is good practice to occasionally compare the OCV of the component cells of a battery bank (if the inter-cell connectors are accessible). This will allow you to identify the sluggish cells. The sluggish cells should be given an identifying mark and used to regularly monitor the battery bank. The sluggish cells can then be used to identify when next to apply a boost charge to the battery bank. You never want a variation between the best and the worst cell of more than 0.05 volts.

A NiCad battery has an OCV of about 1.25 volts per cell and its variation between charged and discharged is difficult to measure as the voltage varies so little.

Charging Voltage

The voltage of a battery being charged can give you an indication of when that battery has reached full charge. This is NOT an OCV.

Whilst charging the voltage of a battery may not vary much for most of the charge and then rise quite dramatically once the battery is full. A Lead Acid battery voltage will rise to between 2.3 and 2.4 volts per cell when fully charged. If a Lead Acid battery has been left in a state of partial or total discharge for a long period of time (months) it may be sulphated (definition on page 136) and have a very high internal resistance in which case the charging voltage may behave as if the battery is full when in fact it's not. Taking a specific gravity reading with a hydrometer will then tell you that in fact the battery is not fully charged (see battery section of "Energy from Nature"). Whilst a NiCad battery is being charged the voltage may rise to 1.62

volts per cell. A NiCad battery never suffers from sulphation and the charging voltage can be used very reliably to determine that it is fully charged. The multimeter is not a reliable indicator of the state of charge up until charging is completed.

Measuring Voltage Drop

A voltage drop will only occur whilst there is a current flowing. Voltage drop is directly proportional to the amount of current flowing and the cable length. By comparing the voltage reading at one end of a cable to the reading taken at the other end you can obtain the voltage drop (subtract the lower reading from the higher reading).

To reduce the voltage drop you may need to increase the cable size and improve the connections.

DC Current Measurement

Select the required DC current range (if in doubt start from the highest range and work your way down until a reading can be obtained) with the test leads connected to the points to be measured. Amps are usually measured by breaking the continuity of the positive line and connecting an amp meter between these two points (ie in series), whereas with a DC clamp meter you need to isolate a single conductor (either positive or negative), open the clamp jaws so as to place that single conductor inside the jaws before closing them and reading the display.

An amp-meter on a distribution/meter box to measure discharge rate needs to be able to read the power consumption of the maximum number of things that may be turned on at once. Such a meter would hardly register and hence would be almost useless in measuring the consumption if it is very low. A 12 volt electric fence energizer and a battery powered radio are two examples of appliances that are usually on for long periods of time whose power consumption is quite low. If an appliance is on continuously for a long period of time even small power consumption will accumulate to be quite significant and from that point of view it is good to be able to measure it.

Testing the Current Consumption of a Light or Appliance Make sure that the appliance or whatever that you are about to measure is turned off. If you have all your positive connections made at one common link it may be easiest to break the continuity at this point. Links often have numbers stamped into the brass to identify the wire locations. Simply undo the screws that hold the wire in question. Finger tighten the screws back onto your positive probe, fix an alligator clip onto the negative probe to hold onto the end of the wire that just came out of the link. Once all your connections are secure you can turn the appliance on and check its current consumption.

Checking the Charging Rate of a Solar Panel

Again you need to break the continuity of the positive line. This time you don't need to turn anything off first. This time the positive probe connects to a point that connects back to the panel and the negative probe connects to a point that goes on to the battery bank. You can isolate and measure individual solar panels by measuring on the solar panels directly or you can measure the output of all the solar panels combined by removing the solar fuse on the distribution/meter box and using the fuse contacts as your test points.

Power (Watts) versus Current (Amps)

To calculate the power consumption of an appliance or the power output of a solar panel, simply multiply the measured current by the measured voltage.

Power Loss (Watts)

The power loss of cable and connectors is calculated by multiplying the measured voltage drop by the measured current flow (see 'Measuring Voltage Drop' and 'Testing the Current Consumption of a Light or Appliance' - above).

Amp-Hours and Watt-Hours

Amp-hours is calculated by multiplying the current (amps) by the number of hours that that current has been flowing for. To calculate watt-hours, multiply amphours by measured volts.

Testing for Continuity

In order to measure continuity you need to have a voltage source. If there is a poor connection or a break in the house wiring it can often be located by tracing the wires from the battery bank outwards and using the battery bank as your voltage source.

With the meter on the appropriate voltage scale start by measuring the voltage at the battery. Now move to the next location where you can connect your probes as you head towards the possible location of the fault.

If at any point you measure no voltage then there is a break in the wiring between the previous test point and this one.

If you measure a drastic voltage drop (particularly with a small load turned on) this may indicate a poor connection such as a wire that is almost broken, corrosion in a connector or a wire, or it may be due to undersized wiring.

Testing if a light bulb is OK

This test can only be applied to incandescent type light bulbs. Fluorescent lights will not respond to this test. It would be easier in this case to use one of the ohms scales on the meter or to use the continuity function if it has one. To make these functions work the multimeter should have an internal battery.

Some multimeter's have a built-in continuity function which often sounds a buzzer. Test this by selecting continuity on the range switch and touching the two probes together. If it buzzes try holding the probes onto the two contacts of the light bulb and see if it buzzes - if it does the light bulb is OK.

Using Ohms (S) for Continuity

If you do not have a continuity function on your multi-meter you can use one of the ohms scales. If you select an ohms scale and touch the probes together you should see the needle of an analog meter move right across the scale and a digital meter should change from reading maximum resistance to zero. Most digital meters will show a high number which flashes (over range) when the circuit is broken (no continuity).

If you get the appropriate response from your meter, hold the two probes onto the light bulb contacts. If the needle of the analog meter moves across the scale or if the digital meter reads zero or a low number then there is continuity and the light bulb is OK.

Testing if a diode is OK

A diode is like a one-way valve. It should allow the current to only flow in one direction and prevent the current from flowing in the other direction. A good diode should show continuity in one direction and no continuity (or over range) in the other.

Do not test the diode whilst there is an external voltage (eg solar panel) connected as this will effect the outcome and possibly damage the meter.

Connect the probes to the device you want to check and note the meter reading. Reverse the probes and note the second reading. If the one reading shows some value and the other is overrange, the device is good. If both readings are overrange, the device is faulty (open circuit). If both readings are very small or zero, the device is also faulty (short circuit

6. Wiring up the Solar Array

You will find that a lot of emphasis is placed on using a sufficiently large wire to carry the current. Choosing the optimum size cable is often a compromise between minimizing the voltage drop in the cable on the one hand and financial constraints on the other.

How much voltage drop is allowable in different circumstances depends very much on the difference in voltage between the battery voltage at full charge and the open circuit voltage of the solar panels. Because Nicad batteries will charge up to a higher voltage, there is less voltage difference between the panels and the batteries. To compensate for this, it is recommended to use the next larger size of cable than is presented in the tables below. The following tables are a guide. Although you may use a larger cable it is recommended not to use a wire of lesser size.

All the figures are based on the use of 36 cell solar panels.

The wire sizes (in the body of the tables) are a measure of conductor cross sectional area and are given in square millimeters (mm²).

12 Volt Battery Bank

		Solar Panel Current in Amps									
m*	2.5	5	7.5	10	15	20	25	30	35	40	
10	2	2	3.2	3.2	5	7.5	7.5	15	15	15	
20	2	3.2	5	7.5	15	15	15	21	21	26	
30	3.2	5	7.5	15	15	21	26	26	36	36	
40	3.2	7.5	15	15	21	26	36	36			
50	5	7.5	15	15	26	36	36				
60	5	15	15	21	26	36					
70	5	15	15	21	21						
80	7.5	15	21	26	36						
90	7.5	15	21	26	36						
100	7.5	15	26	36							

24 Volt Battery Bank

		Solar Panel Current in Amps									
m*	2.5	5	7.5	10	15	20	25	30	35	40	
10	2	2	2	2	3.2	3.2	5	5	5	7.5	
20	2	2	3.2	3.2	5	7.5	7.5	15	15	15	
30	2	3.2	3.2	5	7.5	15	15	15	15	21	
40	2	3.2	5	7.5	15	15	15	21	21	26	
50	2	5	7.5	7.5	15	15	21	26	36	36	
60	3.2	5	7.5	15	15	21	26	26	36	36	
70	3.2	5	7.5	15	15	21	26	36	36		
80	3.2	7.5	15	15	21	26	36	36			
90	3.2	7.5	15	15	21	26	36				
100	5	7.5	15	15	26	36	36				
120	5	15	15	21	26	36					
140	5	15	15	21	36						
160	7.5	15	21	26	36						
180	7.5	15	21	26							
200	7.5	15	26	36							

m* Cable route length measured in metres.

NOTE: The route length is the point to point distance and it includes both positive and negative conductors (ie half the total conductor length). These figures assume a maximum 10% transmission loss. The wire sizes specified will give more than 90% efficiency in energy transfer. For a higher level of efficiency, use the next larger wire size.

7. Wiring Solar Panels And Batteries

There are three types of wiring configurations that are relatively easy to learn. Once mastered, the job of wiring batteries or solar modules becomes easy as pie. The three configurations are:

Series wiring

Parallel wiring

And a combination of the two known simply as series/parallel wiring.

In any DC generating device such as a battery or solar module, you will always have a negative (-) terminal and a positive (+). Electrons or (current) flows from the negative terminal through a load to the positive terminal.

For ease of explanation we shall refer to a solar module or battery as a "Device"

Series Wiring

To wire any device in series you must connect the positive terminal of one device to the negative terminal of the next device

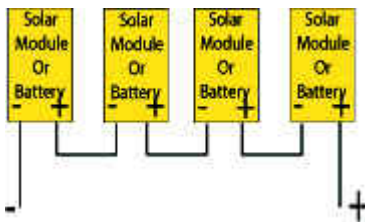

Important: When you wire devices in series the individual voltages of each device is additive. In other words if each device in the above example had the potential of producing 12 volts, then $12 + 12 + 12 + 12 = 48$ volts. If these devices were batteries then the total voltage of the battery pack would be 48 volts. If they were solar modules that produced 17 Volts each then the total voltage of the solar array would be 68 volts.

The second important rule to remember about series circuits is that the current or amperage in a series circuit stays the same. So if these devices were batteries and each

battery had a rating of 12 Volts @ 220 Amp hours then the total value of this series circuit would be 48 Volts @ 220 Amp hours. If they were solar modules and each solar module had a rating of 17 volts and were rated at 5 amps each then the total circuit value would be 68 volts @ 5 amps.

In the example below two 6 Volt 350 Amp hour batteries were wired in series which yields 6 Volts + 6 Volts = 12 Volts @ 350 Amp hours.

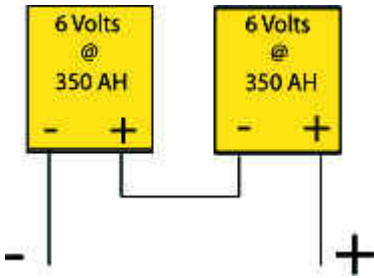

If the above devices were solar modules which were rated at 17 volts each @ 4.4 amps then this series circuit would yield 34 volts at 4.4 amps.

Remember the Voltage in a series circuit is additive and the Current stays the same.

Parallel Circuits

To wire any device in parallel you must connect the positive terminal of the first device to the positive terminal of the next device and negative terminal of the first device to the negative terminal of the next device.

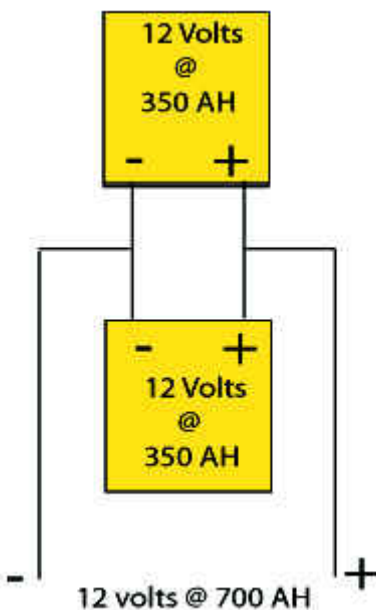

Important: When you wire devices in parallel the resulting Voltage and Current is just the opposite of a series circuit. Instead the Voltage in a parallel circuit stays the same and the Current is additive. If each device in the above example had the potential of producing 350 Amp hours then $350 + 350 = 700$ Amp hours, the Voltage would stay the same.

If these devices were batteries then this parallel circuit would yield total voltage of 12 volts @ 700 Amp hours. If these devices were solar modules that produced 17 Volts @ 4.4 amps each then the this parallel circuit would yield 17 Volts @ 8.8 amps.

In the example below four 17 Volt @ 4.4 Amp solar panels were wired in parallel which yields $4.4 \text{ Amps} + 4.4 \text{ Amps} + 4.4 \text{ Amps} + 4.4 \text{ Amps} = 16.6$ amps total @ 17 volts

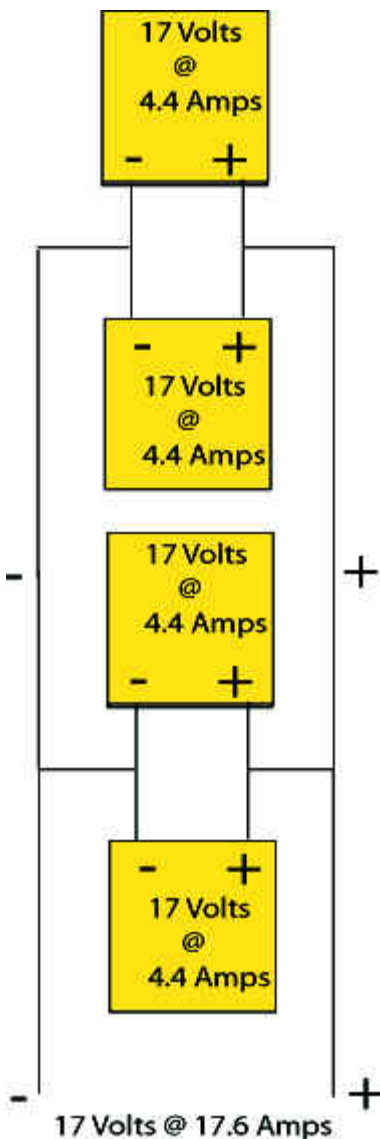

if the above devices were batteries which were rated at 12 volts each @ 220 Amps hours then this parallel circuit would yield 12 volts @ 880 Amp hours.

Remember the Voltage in a parallel circuit stays the same and the Current is additive.

Series/Parallel Circuits

Hold on to your hats because here's where it gets a little wild. Actually you've already learned all you need to know to understand series/parallel circuits.

A Series/parallel circuit is simply two or more series circuits that are wired together in parallel.

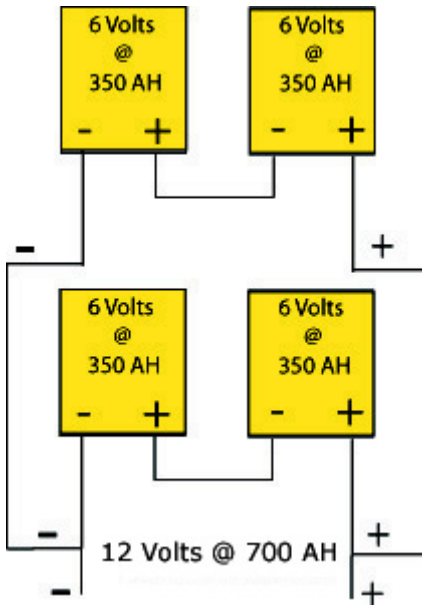

In the above example two separate pairs of 6 Volt batteries have been wired in series and each of these series pairs have been wired together in parallel.

You might be asking why in the world would someone want to put them self through this? Well lets say that you want to increase the Amp hour rating of a battery pack so that you could run your appliances longer but you needed to wire the pack in such a way as to keep the battery pack at 12 volts, or you want to increase the charging capacity of your solar array but you needed to wire the solar modules in such a way as to keep the solar array at 34 volts, well, series/parallel is the only way to do that.

Remember in parallel circuits the current is additive so thus you increase your run time or Amp hour capacity or in the case of solar modules, you increase your charging current by wiring the batteries or solar modules in parallel. Since we need 12 volts and have 6 volt batteries or in the case of solar modules we need 34 Volts and have 17 Volt modules on hand on hand, wiring the batteries or solar modules in series allows us to get the 12 Volts or 34 Volts that we need.

An easy way to visualize it would be to start by wiring the batteries in individual sets that will give you the voltage that you need. Let's say that you need 24 volts but have six volt batteries on hand. First wire four of the batteries in series to get 24 volts. (Remember wire in series to increase the voltage) and continue to wire additional sets of four batteries until the batteries are used up.

Next wire each series set of four batteries in parallel to each other (Positive to positive to positive and so on and then negative to negative to negative and so on) until each series set is wired together in parallel. If each series set of batteries equals 24 Volts at 350 Amp hours then five series sets wired to each other in parallel would give you a 24 Volt @ 1750 Amp hour battery pack.

Remember: In a series circuit the current stays the same but the voltage is additive. In a parallel circuit the voltage stays the same but the current is additive.

8. Mounting Solar Panels

If you are not using a solar tracker, solar panels need to face the midday sun at an angle roughly equal to the latitude of your location. The angle that you choose would depend on the time of year that you need the most power. In the southern hemisphere you would of course face your panels to the north but whether you use magnetic north or true north is not critical.

A variation of up to 15° will not make a great deal of difference in the performance of the panels. You should never have stationary solar panels placed at less than 5° from the horizontal so that they don't collect too much dirt etc and they will automatically wash clean whenever it rains.

By having your panels following the sun with a solar tracking device you can gain greater benefits in summer than in winter. This is due to the difference in the arc that the sun sweeps across the sky which is more than 180° in summer and less than 180° in winter. The degree of variation depends on latitude and weather patterns with the greatest gain coinciding with clear skies and summer. The following table shows the best array angles for 28 different locations around Australia. The solar array would either be facing north on a fixed frame (at an angle from the horizontal to get the best results); or on a polar axis tracking device (tracking the sun from sunrise to sunset).

9. Choosing an Inverter

Selecting an inverter to meet your needs is a major decision. Inverters are quite costly and we tend to become very dependent on our power sources. In some cases, your entire house, including your lights and fridge may be powered from it. Before we go

into the choice of an inverter, I'd suggest that we almost always recommend using a DC fridge (and not an AC one) through your inverter. We often suggest that some or all of your lights be run straight off the battery bank.

Lately there has been quite a proliferation of economical imported inverters coming into the country.. Like a lot of things in life 'you get what you pay for' and 'if it is too good to be true, it probably isn't'.

In selecting an inverter to meet your needs, you will have to look at the type of loads you have - their wattage, power factor, continuous and surge power requirements. Also assess whether or not a cheaper modified square wave inverter would do the job. Once this determination is made, a specific model inverter needs to be chosen.

What are some of the things one should consider?

WATTAGE: This is usually the first and often only thing that an uninformed person may look at. Biggest is not necessarily best! Inverters are usually given a continuous, intermittent (30 minute), and surge rating. Be wary of inverter specifications that don't give you such ratings. I've seen some imported units with the surge rating in huge print and the continuous rating in the fine print. Large inverters will be less efficient on very small loads than smaller inverters. Lightweight inverters with no transformer generally do not have much surge ability.

OUTPUT WAVE SHAPE: A true sine wave is best. Cheaper inverters don't mention it, or are termed modified square or sine wave. Many appliances including fans, washing machines, stereos, digital clocks and timers, will not work satisfactorily on this type of inverter. Many items will run slower, or hotter or noisier on square wave type inverters.

FREQUENCY AND DISTORTION: Good inverters typically hold their frequency to within .01% and have less than 4% harmonic distortion.

AUTOSTART: Does the inverter have a standby/autostart mode? This typically reduces the DC load to about 0.05 Amps when there is no load on. I've seen cheaper inverters drawing 2 Amps continuously with no loads on! Is the demand start sensitivity adjustable in case you want it to start up with say one fluorescent light?

MINIMUM INPUT CURRENT: How much power does the inverter use if it is on 'run' mode to run or detect a very small load? A good inverter might only use 0.6 Amps.

INPUT VOLTAGE: A battery on a solar system may typically vary from as low as perhaps 10 volts up to 15.5 volts when the solar is 'equalizing'. A good inverter will generally operate between 10 to 16 volts.

OUTPUT VOLTAGE: Will it maintain its AC voltage to 3-5%?

EFFICIENCY: How efficient is the inverter? Does the specification just give you one 'peak efficiency' or does it show you a graph with small 50-100 Watt loads up to its rated power?

SAFETY: Does the inverter meet all relevant safety standards? In Australia these would include AS 3100 and AS 3108 and 'C Tick' with respect to low radio frequency interference. Can your electrician install it through a 'safety switch'.

DISPLAYS: Does the inverter identify common faults such as low and high battery, overload, over temperature, etc?

WARRANTY: How long is the warranty? Our good inverters come with a 5-year warranty. Where do you have to return it to for warranty? For example, US is a big country. Are there service agents in most states?

CONCLUSION: The choice of an appropriate inverter is an important and complex choice. Consider carefully the recommendations of an experienced solar designer and think twice about buying the cheapest products you can find!

Heavy loads not usually run on an inverter

Because of the high capital cost of Renewable Energy products like solar panels, appliances that use a very large amount of power are usually excluded from such systems. Some examples are large electric stoves and ovens, air conditioners, pool pumps and cool rooms. If such items are required, then a diesel hybrid or back-up system is usually suggested.

However, solar power is cost effective for running most other appliances in a rural house. Lighting, TV, computer, washing machine, VCR, efficient fridges, ceiling fans, FAX, bread oven, microwave oven, coffee maker, toaster, blender, sewing machine etc are often run off a solar system.

Radio Frequency Interference from Inverters

For many years, Radio Frequency Interference (RFI) has been an annoying problem for owners of Inverters. RFI in a domestic situation may produce noise or interference on a radio or TV receiver. Most of the problems with RFI in a Remote Area Power Supply (RAPS) installation involve AM radio reception. REMEMBER THOSE, YES STILL IN USE.

Considerable development time has resulted in a reduction of RFI produced by a Inverter to a level which complies with C- tick requirements. Compliance to this standard mean RFI is low, but how well the inverter performs in a particular

installation can vary. Below are some help to reduce the effects of RFI.

It is recommended that the power system including the inverter is housed at least 15 meters from the home.

Ensure a good earth stake (ground) is placed as close to the inverter as possible.

Avoid running DC cables into the home, if at all possible. If this cannot be avoided, run DC and AC in separate conduits separated by as much distance as practicable. All DC wiring should also be kept as short as possible.

To further reduce the effects of RFI, it is important that your AM radio has good signal strength. This will enable your radio to reject any noise being produced by your inverter, regulator, controllers or DC lighting. If possible, try moving the radio around to improve the signal strength or use an external aerial. Some of today's building materials such as steel roofs and foil insulation may form a barrier to incoming radio signals. If an external aerial is required, it should be on the outside of the home, mounted as high as practicable and as far from the battery shed as possible.

Connection from the aerial to the radio should be via a low loss coaxial cable. Please note: This aerial must be an AM radio type; a TV aerial will not work. If your inverter is to be installed in a mobile home or similar, try to keep your inverter at least 1 metre away from your radio or audio equipment - the further the better.

10. Panel Assembly.

Solar/photovoltaic panels are used to change the sun's energy into usable electricity. Each panel is made up of a number of solar cells, depending on the voltage you expect or are want to get out of it.

Each cell creates a little more than .5 volts DC, no matter what the size. The only thing that changes with size is the amperage/current. If you take a .5 volt @ 3 amp solar cell and break it in half, you get two .5 volt @ 1.5 amp cells. Each cell has positive leads on the bottom and negative leads on top. Wire it up and you got a panel!

This panel is made out of 3/4" plywood instead of tape and cardboard like I've heard from others. I built this one because it is less expensive than buying new and very durable to last outdoors for years. This panel is made of 90 cells, which will end up being about 16.5 volts @ 9~Amps.



First, we start with a base for the panel. Each cell here is 3"x6" so for 90 cells, I used a 60"x35" piece of 3/4" plywood. I then cut 1 1/2 rails to go around the edge and to separate it into 3 sections. That way the glass has more support in the middle, and if it breaks, it won't do as much damage. After I put the rails on, it's time to start sealing it up. I choose some Bondo Fiberglass Resin to coat it, because it will act like a hard plastic, and keep out moisture.

Note: Fiberglass resin is a polyester resin and will NOT keep out moisture very well. The best thing to use, which I'm switching to is aluminum epoxy type sealer called ALUTHANE, (search for it on the Internet).



For each section, cut a piece of 1/4inch plywood (or you can use cardboard, or foam, since it will be protected from the elements), to fit into each one. These will be holding your cells. Use a pencil and map out where the cells are going, and drill holes between each cell, where the wires will meet.



While waiting for everything to harden up, and apply a 2nd coat, I start the soldering. This is the tedious part that you need patience for. Each cell has 2 strips on the top and 6 rectangles white rectangles on the back for soldering. There are two ways of connecting the cells: You can use the tabbing that most of them come with on the front, and just solder the end hanging off to the back. If you don't do that, you have to buy extra ribbon and solder a strip to the back of each cell. That way if one breaks it will be easier to go back and disconnect later. Since the first way makes repairing incredibly hard, I went with the second method.

Tip: A flat tip 30 watt soldering iron and Silver Bearing solder works the best. You can get silver solder at any Radio Shack. Touch the iron to the rectangle on the back of the cell (each of 6) and feed a little solder into it. That should leave a little drop of solder connected to the cell.

Now complete the cell, Do all six.

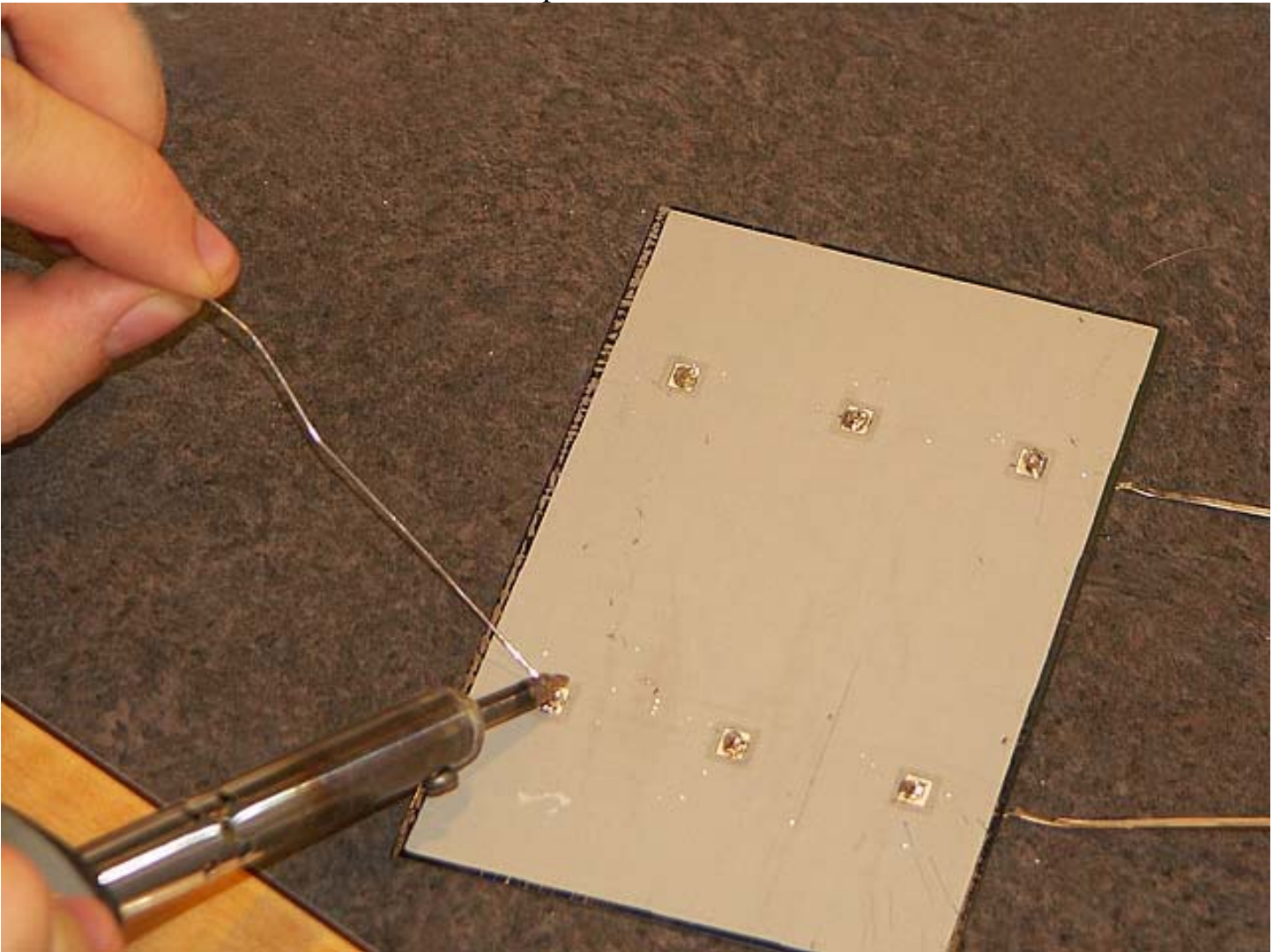

Then stick the ribbon(the metal strips) on top of the droplets in the opposite direction as the negative(top) wires, and touch the iron on top of each one to melt the solder around the ribbon.

Do this to all the cells.

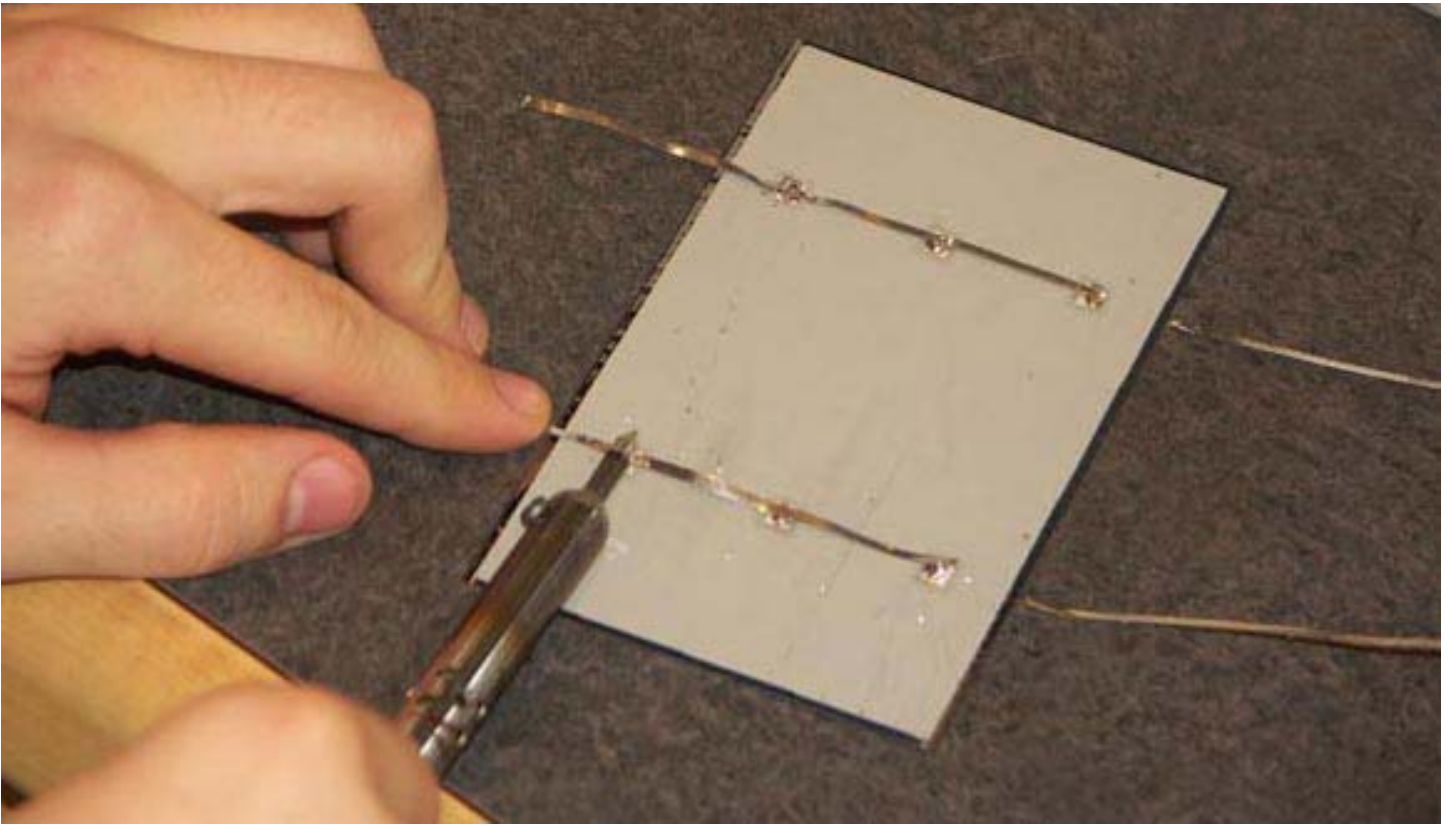

Now to attach the cells. We have to make sure we stick them on in the right direction; because once they go on they don't come off. Each row will switch which end of the cells is sticking up, looking like a snake pattern. On each section piece that you cut, put 3 strips of double sided tape for each cell, to hold it in place. Then, feed the wires for the first cell through the holes, and stick it on there. We have to be careful because the cells are very brittle and break very easily. I suggest using a dry rag to press lightly on each one, that way you avoid finger prints as well.



Continue to stick more cells on until it's complete.



When we're done, lay it down on a flat surface (like a rug) upside down and carefully solder the wires which are coming out of the same holes, together. Notice the ends connected together.



Now we have to do the final wiring. Connect the sections together by soldering wire or a metal strip between each one. Remember, all the positives together and negatives together. If we don't wire this way (Parallel), then we will have 45 volts and 3 amps. We want 15volts and 9amps. Also to have the power outside the panel, so I'm drilling 2 holes for a positive and negative bolt to go through. We cannot forget that drilling into the wood will be the spot will moisture will try and get in, make sure it is sealed up good with resin or epoxy.



And since we are putting this on a tracker with 3" steel square tubing, we attached four bolts sticking out the back, to bolt it to the tracker.



Since we're all done with the cells, we can place them in the panel. Now it's starting to come together.



Finishing it up: I'm using silicone around the edges to seal it up water tight and help hold it on. The silicone will stay forever flexible so I can remove the glass for any reason later on. After you lay the glass down, get some 3/4"-1" angle aluminum to put along the top edge to hold the glass on. Drill holes in the side to screw the aluminum on. This way, when you need to do maintenance, you just unscrew so you don't have use a stronger caulking and chance breaking the glass when you try to get it off.

Now the panel is finished and ready to go up. Two More To Go...



As for cost, I tried to get best looks as possible along with a good sturdy panel. If I wouldn't have gone for the "easy maintenance" path, I could have saved \$40 bucks. I believe that's probably what I'll be doing next time.

Free	Wood
Free	Glass
\$28!	Aluminum
\$80	Cells
\$10	Double side tape
\$2	Extra Ribbon (1000ft for \$50)
\$3	Solder
\$5	Silicone Caulking
\$5	Junction Box
\$4	Bolts, nuts, etc...
\$13	Resin

Total = \$150

11. From Panel To Outlet... It's not Rocket Science!

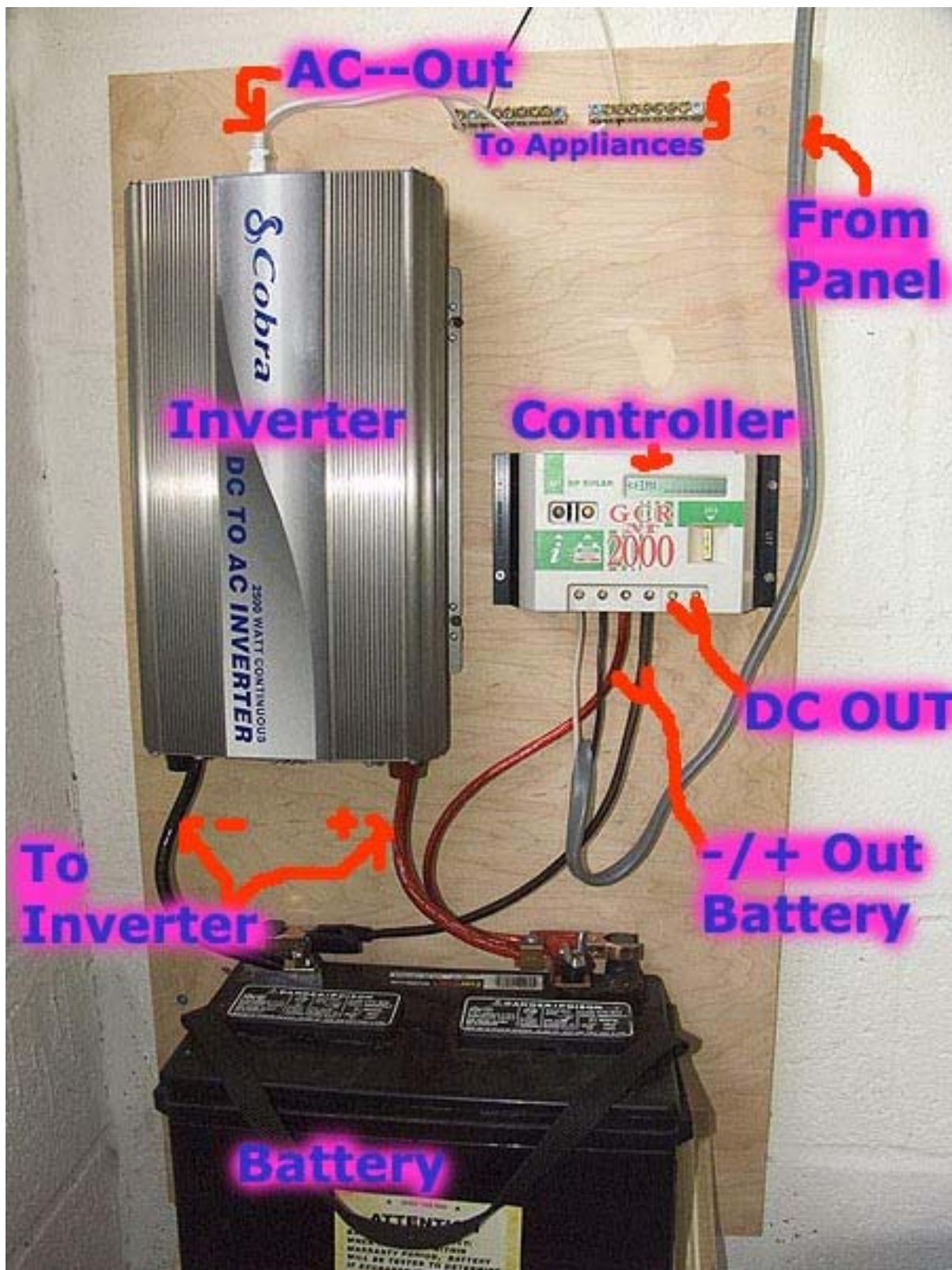

WARNING: Electricity is dangerous, and should be done with extreme caution. Never leave high voltage leads open to be touched by anyone as you see here. This setup has a protective front which is not shown to take this picture but covers should almost always be on. Also if a large battery array is used remember to vent it. Batteries produce Hydrogen Gas when confined and mixed with oxygen, a small spark creates a big powerful explosion and could literally blow it apart.

You can have as many panels as you want, but until you have the right electronics, the power created could be useless. The power you are creating has to be stored, or at night time you will have no power. For this we use batteries. Not just your everyday AA batteries though, we need what is called a deep cycle battery. Deep cycle batteries are made to be discharged, and charged back up, many many times. If you did that with a normal car battery, it would not live very long. Deep cycles are use in boats for trolling, in golf carts, and even in some forklifts. If you like to scrounge, ask around your forklift dealers and certain manufactures (they all use forklifts) for the ones they throw out. Golf courses can be good as well.

Now, just hooking your panels up the batteries can over charge them (kill them), or drain them at night(kill them). In order to do this you have to use a Charge Controller (CC). A CC measures the voltage of the battery, and of the panels. When the battery is full, the charge controller breaks the connection, stopping the charging. Or if the panels are less than the battery (IE: night) it will break the connection again.

Now, to turn this DC power into an every day outlet pug in, you have to get an Inverter. Inverters switch the voltage to AC and boost it to 120+- volts. Just look at the picture above it needs no explanation, don't make it harder than it is.

Solar panel=\$150 built from scratch

Charge Controller=\$65

Battery=\$65 Wal Mart (testing set-up)

Inverter=\$180 from a friend

Wire & Misc.=\$50

Total=\$445

NOTE: The water level in Lead Acid Battery Arrays (in each battery) must be checked and the water level maintained using only distilled water. Make sure the metal fins are covered with water... Check Every two months.

Just DO IT!!!

Remember the installation cost is one time, The energy produced is forever FREE...

###

Copyright 2001 Zadik Publishing, all rights reserved