



Gummi · Metall · Technik

Stabilizer Link
GMT No. 65087601

Maintenance Manual

Stabilizer Link

GMT No. 65087601

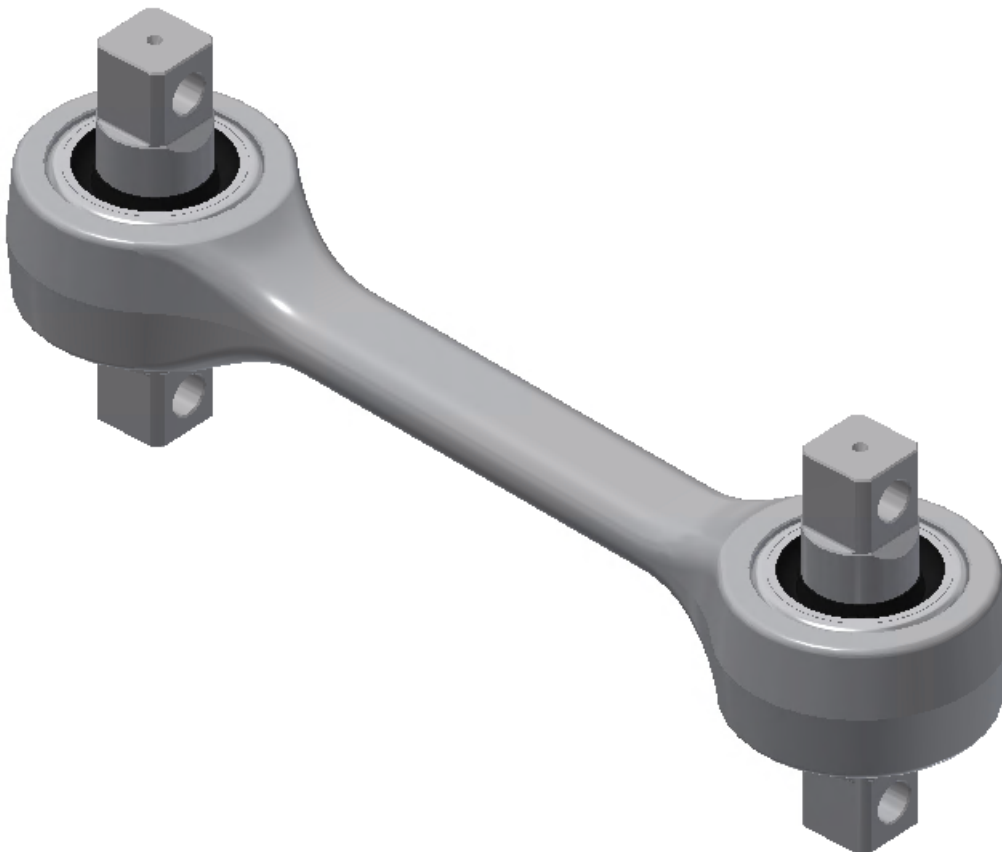

Freigabe

Date	Document Number	Index	Page
2020-07-01	WH_65087601_Stabilizer Link_en	00	1 20



Gummi · Metall · Technik

Stabilizer Link
GMT No. 65087601

Table of Contents

1	On this manual	4
1.1	Applicable Documents	4
1.2	Presentation convention	4
2	Safety	5
2.1	Safety instructions	5
2.2	Accident prevention regulations	5
2.3	Graduated warning and safety messages	5
2.4	Intended Use	5
3	Product description	5
3.1	Designation of delivery item	5
3.2	Description of delivery item	5
3.3	Technical specifications	6
3.4	Identification	6
4	Transport and Storage	6
4.1	Transport	6
4.2	Storage	6
5	Assembly	8
5.1	Mounting instructions	8
5.2	Mounting	8
6	Initial operation	9
7	Operation	9
8	Maintenance	10
8.1	Maintenance intervals	10
8.2	General instructions	10
8.3	Range of coverage	10
8.4	General	10
8.5	Service life and Control	11
8.6	Replacement	12
8.7	Media resistance	13
8.7.1	General information	13

Freigabe

Date	Document Number	Index	Page
2020-07-01	WH_65087601_Stabilizer Link_en	00	2 20



Gummi · Metall · Technik

8.7.2 Resistance against environmental impacts and loads 13

8.7.3 Resistance against machine cleaning 13

8.8 Cleaning 14

8.9 Fire protection 15

9 Decommissioning 15

10 Disassembly 15

11 Disposal 15

12 Error identification 16

13 Annex 16

14 Subject Index 18

15 Index 19

Freigabe

Date	Document Number	Index	Page
2020-07-01	WH_65087601_Stabilizer Link_en	00	3 20

1 On this manual

INFORMATION

These maintenance instructions for rubber-metal components refer exclusively to the visual inspection of the components when installed during operation in the vehicle depot.

The separate maintenance instructions of the vehicle manufacturer are authoritative for the inspection and main inspection of the bogies!

This maintenance manual describes the necessary maintenance operations incurring throughout the service life of the rubber metal parts.

Proposals are made for the necessary tools and auxiliary devices and the necessary dimensions are named.

The maintenance intervals are based on the specification data and may be adapted according to the findings from the operation.

Criteria are described in which the parts are to be replaced or respectively forwarded to the supplier for an assessment of the further applicability.

1.1 Applicable Documents

- Drawing GMT No. 65087601
- DIN 7716:1982-05: Rubber products; requirements for storage, cleaning and maintenance
- ISO 2230:2002-04: Rubber products - Guidelines for storage
- DIN EN 13913:2003-08: Railway applications - Rubber suspension components - Elastomer-based mechanical parts
- DIN EN 45545-1:2013-08: Railway applications - Fire protection on railway vehicles

1.2 Presentation convention

The following representations are used in these manual:

NOTICE



- Indicates situations or maloperation that may lead to material damage.

INFORMATION

- Indicates important information or instructions.
- Failure to comply with these instructions will prevent or substantially hinder the successful completion of the actions described in this documentation.

Date	Document Number	Index	Page
2020-07-01	WH_65087601_Stabilizer Link_en	00	4 20

2 Safety

2.1 Safety instructions



This manual contains important warnings and safety instructions which must be observed by the user.

The product may only be used and operated by qualified personnel who are capable of complying with the necessary safety precautions for use and operation.

The repair of the product may only be carried out by the supplier or by the qualified personnel trained for this purpose.

Any damage resulting from non-compliance with the safety regulations and operating instructions described in this manual are excluded from the warranty and liability claims against the manufacturer!

2.2 Accident prevention regulations

Besides the instructions in this manual, the personnel must be familiar with all applicable local accident prevention regulations and the national safety regulations and must always comply with them.

2.3 Graduated warning and safety messages

The following icons and standard text formats are used in this manual:

⚠ CAUTION	
	<ul style="list-style-type: none">• Indicates a hazard that may result in minor or moderate injuries.• This is the general warning sign. It is used to alert the product user to potential hazards. All safety statements that follow this symbol must be followed in order to prevent possible damage.

2.4 Intended Use

The Stabilizer Link is exclusively intended for installation in rail vehicles. The parts may only be used and installed under the intended operating conditions. Should individual parameters deviate, this must be agreed with GMT GmbH in order to exclude dangers and damage. The intended use also includes the observance of the instructions in this maintenance manual as well as the performance of tests and maintenance.

3 Product description

3.1 Designation of delivery item

Stabilizer Link GMT No. 65087601

3.2 Description of delivery item

- not applicable -

Date	Document Number	Index	Page
2020-07-01	WH_65087601_Stabilizer Link_en	00	5 20

3.3 Technical specifications

Technical Specifications	
Outer Diameter Rod Eye	86 mm
Length Rod	686 mm
Diameter Ball Joint	67 mm
Width Ball Joint	125 mm
Weight complete	12.9 kg
Temperature range / operating conditions	-30 °C to +60 °C

Table 1: Technical specifications

3.4 Identification

Ball Joint GMT No. 64403503

Marking in rubber (raised)

GMT-Logo

Marking in metal (stamped)

Date of manufacture

64403503

4 Transport and Storage

4.1 Transport

- not applicable -

4.2 Storage

The storage of elastomer components is regulated in DIN 7716:1982-05 and ISO 2230:2002-04 and mainly covers long-term storage (longer than 6 months). However, it can also be used for short-term storage (less than 6 months), e.g. production or delivery storage with continuous material flow.

Storage and storage time recording of elastomer components are described in ISO 2230:2002-04. In this standard the elastomer products are divided into three groups with different storage times. These are shown in table 2.

The elastomer of the Stabilizer Link is part of group 1.

Classification acc. to ISO 2230:2002-04	Designation	Storage time (in years)	Extension of storage time (in years)*
Group 1	NR (Natural Rubber)	5	2
Group 2	NBR (Acrylic Nitrile Rubber), CR (Chloroprene Rubber)	7	3
Group 3	EPDM (Ethylene-propylene Rubber)	10	5

* same storage conditions as for the initial storage time

Table 2: storage times of elastomers

Date	Document Number	Index	Page
2020-07-01	WH_65087601_Stabilizer Link_en	00	6 20

The storage temperature should be below +25 °C and products should be stored away from direct sources of heat such as boilers, radiators and direct sunlight.

If the storage temperature is below +15 °C, handle the stored products carefully as they may have stiffened and become susceptible to distortion.

The temperature of products taken from such low-temperature storage should be raised to approximately +30 °C throughout their mass, before the products are put into service.

Care must be taken to ensure that the components are protected from air supply, in particular to keep away the ozone which is detrimental to elastomers.

The storage of elastomeric products in humid storage areas is to be avoided. Condensation should not occur. A relative humidity of 65 % in the storage room is most favorable.

NOTICE



- Solvents, fuels, lubricants, chemicals, acids, brines, disinfectants or suchlike are not allowed in the storage room.

Elastomer products are to be stored stress-free which means without tension, compression or any other deformation since stress promotes a lasting deformation as well as the development of cracks, unless this is provided for constructively.

NOTICE



- Particular metals, especially copper and manganese have a damaging effect on rubber products

Due to this, rubber products should not be stored in contact with these metals but have to be protected by packaging them or by covering them with a layer of a suitable material, e.g. paper or polyethylene.

The material of the containers and the material for packaging- and covering should not contain any damaging ingredients for the rubber products, e.g. copper or copper-containing alloys, petrol, oil or suchlike.

NOTICE



- Foils containing softeners are not allowed to be used as packaging material.

If rubber products have to be powdered, the powder should not contain any harmful ingredients for rubber-products. Appropriate materials for powdering purposes are French chalk, prepared chalk, fine-grained mica flour and rice starch.

Date	Document Number	Index	Page
2020-07-01	WH_65087601_Stabilizer Link_en	00	7 20

5 Assembly

5.1 Mounting instructions

The assembly and disassembly is carried out according to the specifications of the rail vehicle manufacturer.

INFORMATION

- When mounting rubber-metal components, the forces and torques or paths and angles shown on the drawing GMT No. 65087601 (see Annex) are not to be exceeded by more than 20 %.
- If possible, do not introduce the assembly forces via the elastomer.
- Apart from static pre-loads, the components are virtually free of tension after installation.

NOTICE



- In particular it must be ensured that the exposed rubber surface is not damaged during installation.

5.2 Mounting

1. Place the rod eye on a socket.

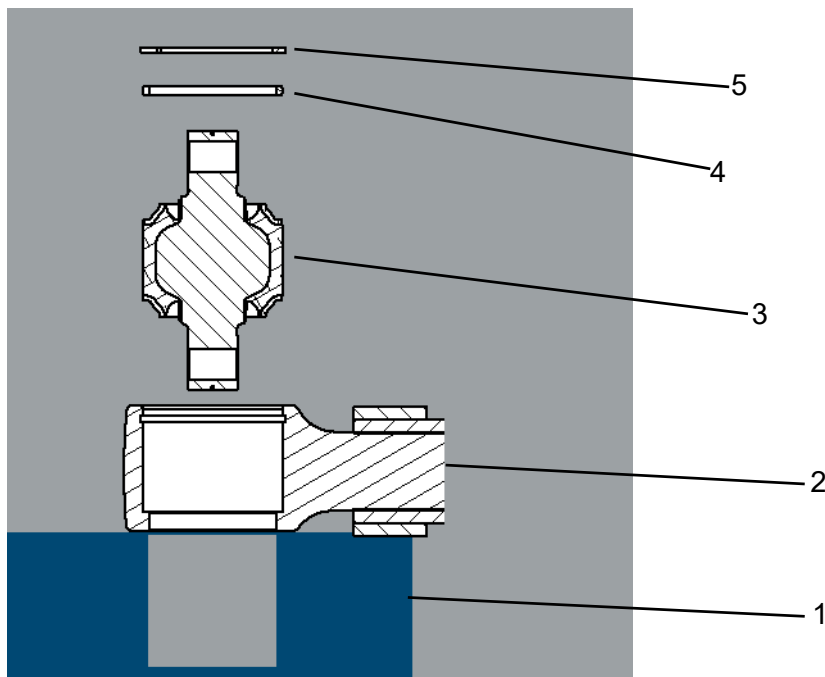

[1] Retaining ring E200449
[2] Spacer ring E200446
[3] Ball Joint 64403503

[4] Rod 99228001
[5] Socket

Figure 1: Mounting 1

Date	Document Number	Index	Page
2020-07-01	WH_65087601_Stabilizer Link_en	00	8 20

Gummi · Metall · Technik

2. Place the Ball Joint, the spacer ring and the retaining ring on the rod eye.



Figure 2: Mounting 2

3. Press in the Ball Joint until the retaining ring springs into the groove.

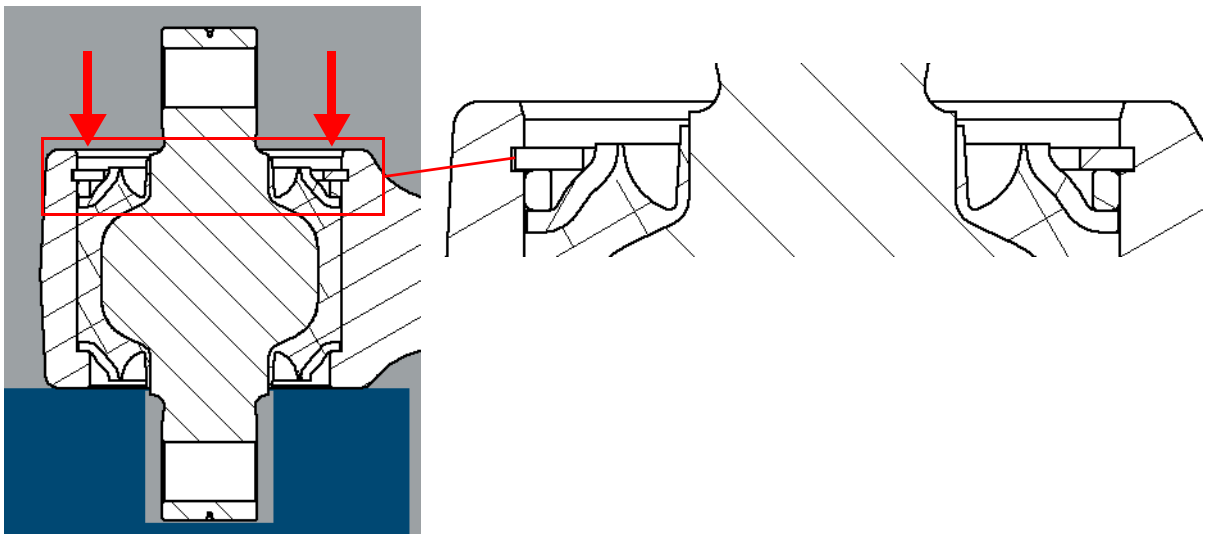

Figure 3: Mounting 3

6 Initial operation

- not applicable -

7 Operation

- not applicable -

Freigabe

Date	Document Number	Index	Page
2020-07-01	WH_65087601_Stabilizer Link_en	00	9 20

8 Maintenance

8.1 Maintenance intervals

Action	Mileage	Chapter
Visual check	<ul style="list-style-type: none"> - within 6 months after installation - thereafter all least once per year - after an operating period of 8 years testing and evaluation with the involvement of the manufacturer 	see chapter 8.5
Bonding test	<ul style="list-style-type: none"> - within 6 months after installation - thereafter all least once per year - after an operating period of 8 years testing and evaluation with the involvement of the manufacturer 	see chapter 8.5
Exchange of elastomer components		see chapter 8.6
Cleaning of elastomer products		see chapter 8.8

Table 3: Maintenance intervals

8.2 General instructions

Controlling, cleaning and maintaining rubber-metal parts and molded rubber parts

8.3 Range of coverage

The following guidelines apply to elastomeric components and rubber-metal components, based on the use of caoutchouc and rubber in pure form. Alternatively to metallic materials partially plastics are used. These documentation were drawn up in line with DIN 7716:1985-05 and ISO 2230:2002-04 and are also valid for the use of synthetic rubber products regarding the general conditions.

8.4 General

Under unfavorable storage conditions or improper treatment most elastomer products change their physical properties. This can lead to a significant decrease in lifetime of elastomer products. For example from excessive hardening, softening, permanent deformation as well as from flaking, cracks or other surface damage they can become unusable. The changes can be caused by the influence of oxygen, ozone, heat, light, humidity, solvents or by storing under stress.

Properly stored and treated rubber products remain virtually unchanged in their characteristics for a certain period of time.

INFORMATION

Rubber-to-metal-bonded parts are mainly suited for the usage in compression- and shear-loads. Pulling-loads should be avoided.

Date	Document Number	Index	Page
2020-07-01	WH_65087601_Stabilizer Link_en	00	10 20

8.5 Service life and Control

Elastomers are subject to a natural aging process and are not durable.

The service life of elastomer-components depends on the design and the strain of the component and conforms to the specific agreements of the order.

INFORMATION

- If elastomer components are only exposed to loads within the permissible range during the operating time, a maximum service life of 8 years can be assumed.
- During this operational period, elastomer components are maintenance-free. This does not exclude a visual inspection or control of the elastomer components.
- A visual inspection of the elastomer components must be carried out no later than 6 months after installation and then at least once a year.
- At the latest after reaching an operating time of 8 years, an examination and evaluation of a representative number of components must be carried out with the involvement of the manufacturer. If necessary, a residual life test should be carried out.

Regular visual inspections are essential for checking the condition of the elastomer components.

When visual inspection or inspection of an elastomer component, take care i.a. on:

- Fatigue cracks at the connecting ends of the elements
- discoloration
- volume changes
- Surface cracks in the body of the element

INFORMATION

- If you experience any damage or irregularities, report immediately.
- Document the observation according to the operational regulations.
- If necessary, replace the faulty element.

The bonding test between rubber and metal can be carried out by hand. The rubber can thereby be pressed back with a dull test-iron (edge with radius).

The use of sharp objects for inspection is not allowed!

NOTICE



- Partial border delamination in the bonding zone between the elastomer and metal or surface cracks in the individual elastomer layers are to be reported immediately.
- These areas must be examined in regular intervals.
- If necessary, a performance and safety test of the components under participation of the manufacturer is to be initiated.

Date	Document Number	Index	Page
2020-07-01	WH_65087601_Stabilizer Link_en	00	11 20

8.6 Replacement

A replacement of elastomer components or elastomer-metal components is required e.g. in the following cases when

- more than 10 clearly visible cracks per cm² have appeared on the rubber surface as a result of atmospheric exposure
- the parts have swollen strongly, due to inadmissible oil-moistening.
- a loss in the rubber-metal bonding (possibly due to rust creep or corrosion of the metal parts) has occurred
- there is mechanical damage which could lead to a further destruction of the product due to sensitivity for notches of natural rubber
- local bulges are visible that do cover the entire side and with a depth of a multiple of the layer thickness
- Frayed bulges occur parallel to metal parts
- an above-average deformation occurs on metal parts of an elastomer-metal component as a result of deflection
- a crack depth >2 mm is reached (both in rubber itself as well as at the transitions to the metal)

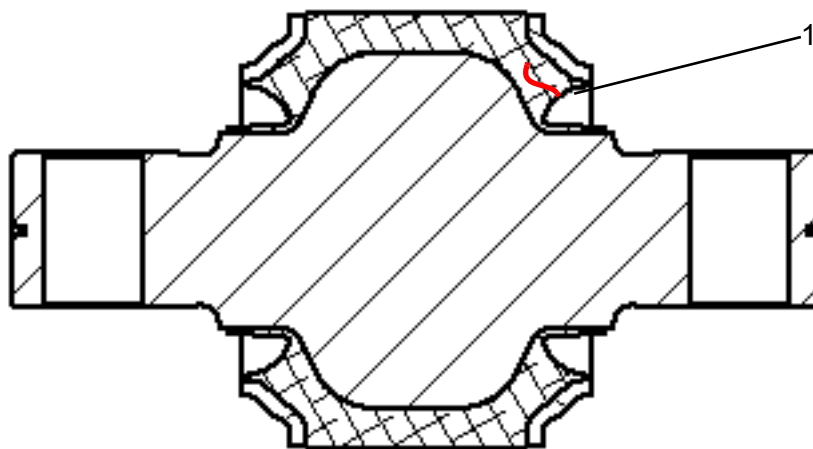

[1] Replacement criterion: crack depth > 2 mm

Figure 4: Crack depth

During operation a white-grayish film might show on the rubber surface. This film is aging protecting wax or compounding ingredients that are blended with the elastomer compound to protect against ozone and other environmental influences. Due to component deformations these ingredients migrate to the surface of an elastomeric component. In the area of wrinkles the film might be levigated.

At first sight, such an area can be diagnosed incorrectly as cracks in the elastomer or sulfur rash. This folding is typical for the structure of the elastomeric surface and is caused by compression of the component and the incompressibility of the elastomer. Should uncertainty persist, report to the supervisor.

Date	Document Number	Index	Page
2020-07-01	WH_65087601_Stabilizer Link_en	00	12 20

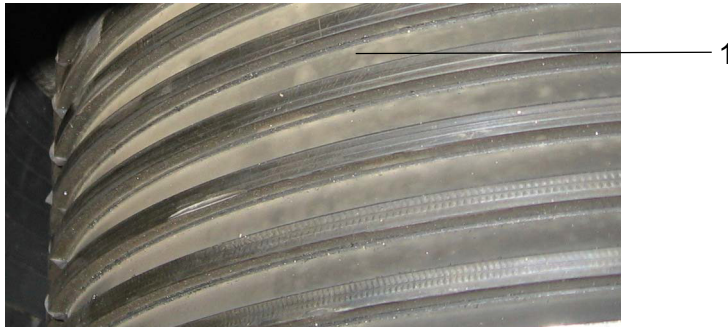

[1] Discoloration

Figure 5: Discoloration example

8.7 Media resistance

8.7.1 General information

The bogie components include rubber compounds out of natural rubber with different shore hardness and related synthetic rubber composites. The chemical resistance of these rubber compounds is chosen according to the mechanical requirements and therefore is comparable among each other.

8.7.2 Resistance against environmental impacts and loads

The rubber compounds used in bogies are resistant to environmental influences under normal climatic conditions which mean temperatures between -30 °C to +60 °C. Resistance against climatic influence, especially against ozone, and higher temperatures, caused e.g. by the waste heat of motors, is improved by the proportioning of appropriate chemicals.

INFORMATION

- The elastomers used are resistant against loads which are usual in railway application.
- Pollutions caused by oil and lubricants as well as feces have to be removed regularly by using cleaning agents commonly used for bogies.
- Elastomers made of natural rubber are not permanently resistant against mineral oils and fuels.

8.7.3 Resistance against machine cleaning

The elastomers used are resistant against phosphoric acids and hydrochloric acids as well as against alkaline cleaning agents used for cleaning of the exterior of vehicles.

The resistance has been proven at selective elastomers made of natural rubber in test fluids according to DIN EN 13913:2003-08 representing other cleaning agents which are customary in trade.

Date	Document Number	Index	Page
2020-07-01	WH_65087601_Stabilizer Link_en	00	13 20

INFORMATION

Non pH-neutral cleaning agents

- Non pH-neutral cleaning agents damage the rubber.
- Use cleaning agents with a neutral pH-value. Do not use cleaning agents containing non-polar solvents (e.g. petrol). The components of the bogie have to be rinsed with water after the cleaning process otherwise the rubber-metal-bonding has to be protected against cleaning agents by constructive measures.

8.8 Cleaning

The components can be cleaned using detergents mentioned in table 4. The specified concentrations as well as the specifications of manufacturer shall be observed obligatorily. The residues of the detergents shall be rinsed with clear water. The cleaned component has to be dried at room temperature.

NOTICE



Use of other differing cleaning agents

- The use of different detergents can damage the rubber.
- Only use detergents mentioned in table 4.

Detergent	Concentration
Alkaline detergent	
Oxalic detergent	
Rapidol A	10 %
Rapidol W	10 %
Rapidol 58	10 %
Rapox	5 %
Rapox OS	5 %

Table 4: Detergents

NOTICE



Cleaning with sharp objects

- The use of sharp-edged objects (e.g. wire brushes, emery paper, etc.) is not permitted for cleaning elastomer products!

Date	Document Number	Index	Page
2020-07-01	WH_65087601_Stabilizer Link_en	00	14 20

Brief overview of resistance behavior or different elastomer compounds:														
	GROUP 1			GROUP 2						GROUP 3				
	NR			NBR	CR						EPDM			
acid resistance	B			B	A						A			
alkali resistance	B			B	A						A			
oil resistance	U			A	B						U			
Resistance to fuel	U			B	U						U			
Solvent resistance	U			B	B						B			
ozone resistance	B			B	A						A			
weatherability	B			A	A						A			
A = very good, little or no attack														
B = satisfactory, moderate to severe attack. Please contact the manufacturer!														
U = unsuitable for the application														

Table 5: resistance behavior of elastomers

8.9 Fire protection

Unless expressly required, elastomers made of natural rubber do not include any fire protection agents. The use of halogen-free fire protection agents causes a reduction in the mechanical properties; therefore, these protection agents are not used in components for dynamic load.

9 Decommissioning

- not applicable -

10 Disassembly

For disassembly, the Ball Joint are pressed in the axial direction. It should be ensured that the force is applied only in the outer, metallic segments of the Ball Joint.

11 Disposal

Disposal / Product:

- Rubber-metal bonded materials with high rubber content may be disposed of in compliance with the local regulations of combustion (e.g. thermal recycling).
- Smaller quantities can be disposed of in compliance with the local regulations in the domestic waste dump.
- After dismantling, metallic components can be disposed of in the metal scrap recycling.

Waste code according to the European Waste List (Waste Catalogue Ordinance):

The AVV waste code numbers are not product-related but are largely source-related. The manufacturer is therefore unable to specify the waste code for articles or products used in various sectors. Waste codes can be requested from the manufacturer.

Date	Document Number	Index	Page
2020-07-01	WH_65087601_Stabilizer Link_en	00	15 20



Gummi · Metall · Technik

Stabilizer Link
GMT No. 65087601

12 Error identification

- not applicable -

13 Annex

- Drawing GMT No. 65087601

Freigabe

Date	Document Number	Index	Page
2020-07-01	WH_65087601_Stabilizer Link_en	00	16 20



Gummi · Metall · Technik

Stabilizer Link
GMT No. 65087601

14 Subject Index

- not applicable -

Freigabe

Date	Document Number	Index	Page
2020-07-01	WH_65087601_Stabilizer Link_en	00	18 20



Gummi · Metall · Technik

Stabilizer Link
GMT No. 65087601

15 Index

GMT	Stabilizer Link	65087601
Manufacturer	Part	Drawing Number
WH_65087601_Stabilizer Link_en		
Document		
2020-07-01	00	C. Palm
Document Created (Date)	Index	Document Created (Name)

State of Revision:

Document Modification										
Mod.	Index (Record Modified Chapters Here)									
	01	02	03	04	05	06	07	08	09	10
1										
2										
3										
4										
5										
6										
7										
8										
9										
10										
11										
12										

Index:

Index	Date	Reason of Modification	Responsibility
00	2020-07-01	First issue	C. Palm

Prepared	Date	2020-07-01	GMT Engineering	Christian Palm
Released	Date	2020-07-01	GMT Engineering	Stefan Schemel

Date	Document Number	Index	Page
2020-07-01	WH_65087601_Stabilizer Link_en	00	19 20

Freigabe



Gummi · Metall · Technik

Stabilizer Link
GMT No. 65087601

Copyright 2020 GMT Gummi-Metall-Technik GmbH

Maintenance instruction Stabilizer Link GMT No. 65087601 Rev. 00

The contents of this publication must not be modified in any manner in whole or in part, nor reproduced in any form or forwarded to third parties without prior written consent of GMT.

The creation of this documentation was carried out with due diligence so that GMT assume no liability for any remaining errors or omissions as well as for any possible resulting damages. All trademarks or registered trademarks are the property of their respective owners.

All rights reserved.

Contact:

GMT Gummi-Metall-Technik GmbH

Liechersmatten 5

D-77815 Bühl

<http://www.gmt-gmbh.de>

Freigabe

Date	Document Number	Index	Page
2020-07-01	WH_65087601_Stabilizer Link_en	00	20 20