

# Maintenance Manual

## Center Pivot Bearing

GMT - No. 41057501



Date	Document Number	Index	Page
2021-11-18	WH_41057501_Center Pivot Bearing_en	00	1   19

## Table of Contents

<b>1</b>	<b>On this manual</b>	<b>4</b>
1.1	Applicable Documents	4
1.2	Presentation convention	4
<b>2</b>	<b>Safety</b>	<b>5</b>
2.1	Safety instructions	5
2.2	Accident prevention regulations	5
2.3	Graduated warning and safety messages	5
2.4	Intended Use	5
<b>3</b>	<b>Product description</b>	<b>5</b>
3.1	Designation of delivery item	5
3.2	Description of delivery item	5
3.3	Technical specifications	6
3.4	Identification	6
<b>4</b>	<b>Transport and Storage</b>	<b>6</b>
4.1	Transport	6
4.2	Storage	6
<b>5</b>	<b>Assembly</b>	<b>7</b>
5.1	Mounting instructions	7
5.2	Mounting the Center Pivot Bearing	8
<b>6</b>	<b>Initial operation</b>	<b>8</b>
<b>7</b>	<b>Operation</b>	<b>8</b>
<b>8</b>	<b>Maintenance</b>	<b>9</b>
8.1	Maintenance intervals	9
8.2	Range of coverage	9
8.3	General	9
8.4	Service life and Control	10
8.5	Replacement	11
8.6	Media resistance	12
8.6.1	General information	12
8.6.2	Environmental impacts and loads	12

Date	Document Number	Index	Page
2021-11-18	WH_41057501_Center Pivot Bearing_en	00	2   19

8.6.3	Resistance against machine cleaning .....	12
8.7	Cleaning .....	13
8.8	Fire protection .....	14
<b>9</b>	<b>Decommissioning .....</b>	<b>14</b>
<b>10</b>	<b>Disassembly .....</b>	<b>14</b>
<b>11</b>	<b>Disposal .....</b>	<b>14</b>
<b>12</b>	<b>Error identification .....</b>	<b>15</b>
<b>13</b>	<b>Annex .....</b>	<b>15</b>
<b>14</b>	<b>Subject Index .....</b>	<b>17</b>
<b>15</b>	<b>Index .....</b>	<b>18</b>

Date	Document Number	Index	Page
2021-11-18	WH_41057501_Center Pivot Bearing_en	00	3   19

## 1 On this manual

### INFORMATION

These maintenance instructions for rubber-metal components refer exclusively to the visual inspection of the components when installed during operation in the vehicle depot.

**The separate maintenance instructions of the vehicle manufacturer are authoritative for the inspection and main inspection of the bogies!**

This maintenance manual describes the necessary maintenance operations incurring throughout the service life of the rubber metal parts.

Proposals are made for the necessary tools and auxiliary devices and the necessary dimensions are named.

The maintenance intervals are based on the specification data and may be adapted according to the findings from the operation.

Criteria are described in which the parts are to be replaced or respectively forwarded to the supplier for an assessment of the further applicability.

#### 1.1 Applicable Documents

- Drawing GMT - No. 41057501
- DIN 7716:1982-05: Rubber products; requirements for storage, cleaning and maintenance
- ISO 2230:2002-04: Rubber products - Guidelines for storage
- DIN EN 13913:2003-08: Railway applications - Rubber suspension components - Elastomer-based mechanical parts
- DIN EN 45545-1:2013-08: Railway applications - Fire protection on railway vehicles

#### 1.2 Presentation convention

The following representations are used in these manual:

### NOTICE



- Indicates situations or maloperation that may lead to material damage.

### INFORMATION

- Indicates important information or instructions.
- Failure to comply with these instructions will prevent or substantially hinder the successful completion of the actions described in this documentation.

Date	Document Number	Index	Page
2021-11-18	WH_41057501_Center Pivot Bearing_en	00	4   19

## 2 Safety

### 2.1 Safety instructions



This manual contains important warnings and safety instructions which must be observed by the user.

The product may only be used and operated by qualified personnel who are capable of complying with the necessary safety precautions for use and operation.

The repair of the product may only be carried out by the supplier or by the qualified personnel trained for this purpose.

Any damage resulting from non-compliance with the safety regulations and operating instructions described in this manual are excluded from the warranty and liability claims against the manufacturer!

### 2.2 Accident prevention regulations

Besides the instructions in this manual, the personnel must be familiar with all applicable local accident prevention regulations and the national safety regulations and must always comply with them.

### 2.3 Graduated warning and safety messages

The following icons and standard text formats are used in this manual:

#### CAUTION



- Indicates a hazard that may result in minor or moderate injuries.
- This is the general warning sign. It is used to alert the product user to potential hazards. All safety statements that follow this symbol must be followed in order to prevent possible damage.

### 2.4 Intended Use

The Center Pivot Bearing is exclusively intended for installation in rail vehicles. The parts may only be used and installed under the intended operating conditions. Should individual parameters deviate, this must be agreed with GMT GmbH in order to exclude dangers and damage. The intended use also includes the observance of the instructions in this maintenance manual as well as the performance of tests and maintenance.

## 3 Product description

### 3.1 Designation of delivery item

Center Pivot Bearing GMT - No. 41057501

### 3.2 Description of delivery item

- not applicable -

Date	Document Number	Index	Page
2021-11-18	WH_41057501_Center Pivot Bearing_en	00	5   19

### 3.3 Technical specifications

Technical Specifications	
Diameter	207 mm
Width	190 mm
Weight	20.3 kg
Temperature range / operating conditions	-30 °C to +50 °C

Table 1: Technical specifications

### 3.4 Identification

#### Marking in rubber (raised)

GMT-Logo

Date of manufacture

41057501

Cavity no.

## 4 Transport and Storage

### 4.1 Transport

- not applicable -

### 4.2 Storage

The storage of elastomer components is regulated in DIN 7716:1982-05 and ISO 2230:2002-04 and mainly covers long-term storage (longer than 6 months). However, it can also be used for short-term storage (less than 6 months), e.g. production or delivery storage with continuous material flow.

Storage and storage time recording of elastomer components are described in ISO 2230:2002-04. In this standard the elastomer products are divided into three groups with different storage times. These are shown in Table 2.

The elastomer of the Center Pivot Bearing is part of group 1.

Classification acc. to ISO 2230:2002-04	Designation	Storage time (in years)	Extension of storage time (in years)*
Group 1	NR (Natural Rubber)	5	2
Group 2	NBR (Acrylic Nitrile Rubber), CR (Chloroprene Rubber)	7	3
Group 3	EPDM (Ethylene-propylene Rubber)	10	5

\* same storage conditions as for the initial storage time

Table 2: storage times of elastomers

The storage temperature should be below +25 °C and products should be stored away from direct sources of heat such as boilers, radiators and direct sunlight.

If the storage temperature is below +15 °C, handle the stored products carefully as they may have stiffened and become susceptible to distortion.

Date	Document Number	Index	Page
2021-11-18	WH_41057501_Center Pivot Bearing_en	00	6   19

The temperature of products taken from such low-temperature storage should be raised to approximately +30 °C throughout their mass, before the products are put into service.

Care must be taken to ensure that the components are protected from air supply, in particular to keep away the ozone which is detrimental to elastomers.

The storage of elastomeric products in humid storage areas is to be avoided. Condensation should not occur. A relative humidity of 65 % in the storage room is most favorable.

## NOTICE



- Solvents, fuels, lubricants, chemicals, acids, brines, disinfectants or suchlike are not allowed in the storage room.

Elastomer products are to be stored stress-free which means without tension, compression or any other deformation since stress promotes a lasting deformation as well as the development of cracks, unless this is provided for constructively.

## NOTICE



- Particular metals, especially copper and manganese have a damaging effect on rubber products

Due to this, rubber products should not be stored in contact with these metals but have to be protected by packaging them or by covering them with a layer of a suitable material, e.g. paper or polyethylene.

The material of the containers and the material for packaging- and covering should not contain any damaging ingredients for the rubber products, e.g. copper or copper-containing alloys, petrol, oil or suchlike.

## NOTICE



- Foils containing softeners are not allowed to be used as packaging material.

If rubber products have to be powdered, the powder should not contain any harmful ingredients for rubber-products. Appropriate materials for powdering purposes are French chalk, prepared chalk, fine-grained mica flour and rice starch.

## 5 Assembly

### 5.1 Mounting instructions

The assembly and disassembly is carried out according to the specifications of the rail vehicle manufacturer.

Date	Document Number	Index	Page
2021-11-18	WH_41057501_Center Pivot Bearing_en	00	7   19

## INFORMATION

- When mounting rubber-metal components, the forces and torques or paths and angles shown on the drawing GMT - No. 41057501 (see annex) are not to be exceeded by more than 20 %.
- If possible, do not introduce the assembly forces via the elastomer.
- Apart from static pre-loads, the components are virtually free of tension after installation.

## NOTICE



- In particular it must be ensured that the exposed rubber surface is not damaged during installation.

### 5.2 Mounting the Center Pivot Bearing

The bushing may only be pressed into the housing via the outer pipe. In order to facilitate the press-fitting process, it is permissible to cool the bushing to  $-25\text{ }^{\circ}\text{C}$  for 24 hours and then to add it to the housing unlubricated.

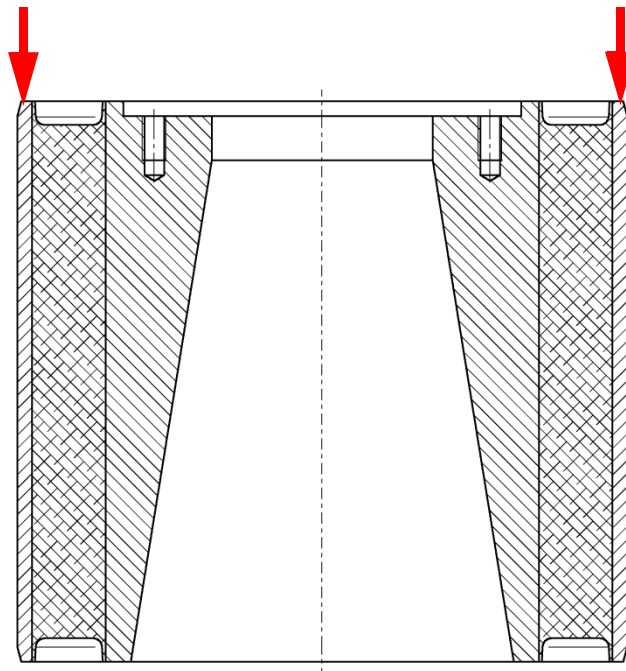

Figure 1: Mounting

## 6 Initial operation

- not applicable -

## 7 Operation

- not applicable -

Date	Document Number	Index	Page
2021-11-18	WH_41057501_Center Pivot Bearing_en	00	8   19

## 8 Maintenance

### 8.1 Maintenance intervals

Action	Mileage	Chapter
Visual check	<ul style="list-style-type: none"> <li>- within 6 months after installation</li> <li>- thereafter all least once per year</li> <li>- after an operating period of 8 years testing and evaluation with the involvement of the manufacturer</li> </ul>	see chapter 8.4
Bonding test	<ul style="list-style-type: none"> <li>- within 6 months after installation</li> <li>- thereafter all least once per year</li> <li>- after an operating period of 8 years testing and evaluation with the involvement of the manufacturer</li> </ul>	see chapter 8.4
Exchange of elastomer components		see chapter 8.5
Cleaning of elastomer components		see chapter 8.7

Table 3: Maintenance intervals

### 8.2 Range of coverage

The following guidelines for controlling, cleaning and maintaining apply to elastomeric components and rubber-metal components, based on the use of caoutchouc and rubber in pure form. Alternatively to metallic materials partially plastics are used. These documentation were drawn up in line with DIN 7716:1985-05 and ISO 2230:2002-04 and are also valid for the use of synthetic rubber products regarding the general conditions.

### 8.3 General

Under unfavorable storage conditions or improper treatment most elastomer products change their physical properties. This can lead to a significant decrease in lifetime of elastomer products. For example from excessive hardening, softening, permanent deformation as well as from flaking, cracks or other surface damage they can become unusable. The changes can be caused by the influence of oxygen, ozone, heat, light, humidity, solvents or by storing under stress.

Properly stored and treated rubber products remain virtually unchanged in their characteristics for a certain period of time.

## INFORMATION

Rubber-to-metal-bonded parts are mainly suited for the usage in compression- and shear-loads. Pulling-loads should be avoided.

Date	Document Number	Index	Page
2021-11-18	WH_41057501_Center Pivot Bearing_en	00	9   19

#### 8.4 Service life and Control

Elastomers are subject to a natural aging process and are not durable.

The service life of elastomer-components depends on the design and the strain of the component and conforms to the specific agreements of the order.

### INFORMATION

- If elastomer components are only exposed to loads within the permissible range during the operating time, a maximum service life of 8 years can be assumed.
- During this operational period, elastomer components are maintenance-free. This does not exclude a visual inspection or control of the elastomer components.
- A visual inspection of the elastomer components must be carried out no later than 6 months after installation and then at least once a year.
- At the latest after reaching an operating time of 8 years, an examination and evaluation of a representative number of components must be carried out with the involvement of the manufacturer. If necessary, a residual life test should be carried out.

Regular visual inspections are essential for checking the condition of the elastomer components.

When visual inspection or inspection of an elastomer component, take care i.a. on:

- Fatigue cracks at the connecting ends of the elements
- discoloration
- volume changes
- Surface cracks in the body of the element

### INFORMATION

- If you experience any damage or irregularities, report immediately.
- Document the observation according to the operational regulations.
- If necessary, replace the faulty element.

The bonding test between rubber and metal can be carried out by hand. The rubber can thereby be pressed back with a dull test-iron (edge with radius).

**The use of sharp objects for inspection is not allowed!**

### NOTICE



- Partial border delamination in the bonding zone between the elastomer and metal or surface cracks in the individual elastomer layers are to be reported immediately.
- These areas must be examined in regular intervals.
- If necessary, a performance and safety test of the components under participation of the manufacturer is to be initiated.

Date	Document Number	Index	Page
2021-11-18	WH_41057501_Center Pivot Bearing_en	00	10   19

## 8.5 Replacement

A replacement of elastomer components or elastomer-metal components is required e.g. in the following cases when

- more than 10 clearly visible cracks per cm<sup>2</sup> have appeared on the rubber surface as a result of atmospheric exposure
- the parts have swollen strongly, due to inadmissible oil-moistening.
- a loss in the rubber-metal bonding (possibly due to rust creep or corrosion of the metal parts) has occurred
- there is mechanical damage which could lead to a further destruction of the product due to sensitivity for notches of natural rubber
- local bulges are visible that do cover the entire side and with a depth of a multiple of the layer thickness
- Frayed bulges occur parallel to metal parts
- an above-average deformation occurs on metal parts of an elastomer-metal component as a result of deflection
- a crack depth >17 mm is reached (both in rubber itself as well as at the transitions to the metal)

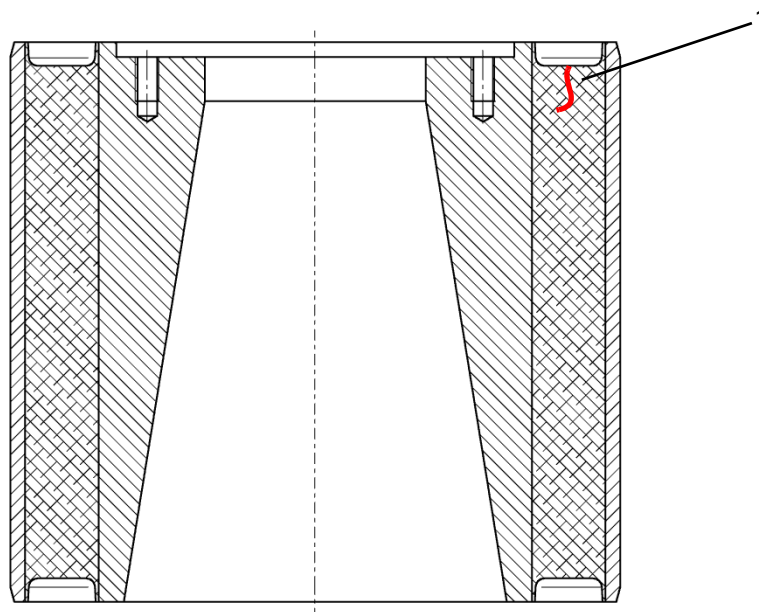

[1] Replacement criterion: crack depth > 17 mm

Figure 2: Crack depth

During operation a white-grayish film might show on the rubber surface. This film is aging protecting wax or compounding ingredients that are blended with the elastomer compound to protect against ozone and other environmental influences. Due to component deformations these ingredients migrate to the surface of an elastomeric component. In the area of wrinkles the film might be levigated.

At first sight, such an area can be diagnosed incorrectly as cracks in the elastomer or sulfur rash. This folding is typical for the structure of the elastomeric surface and is caused by com-

Date	Document Number	Index	Page
2021-11-18	WH_41057501_Center Pivot Bearing_en	00	11   19

pression of the component and the incompressibility of the elastomer. Should uncertainty persist, report to the supervisor.

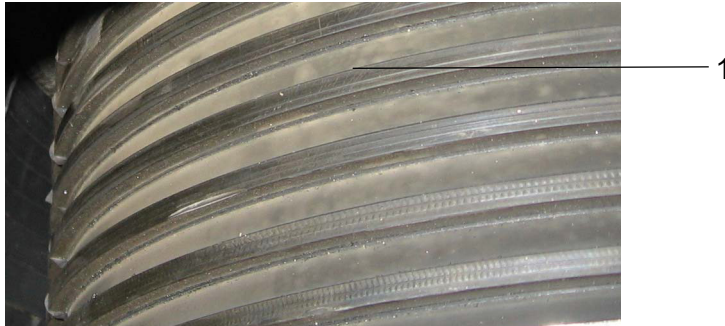

[1] Discoloration

Figure 3: Discoloration example

## 8.6 Media resistance

### 8.6.1 General information

The bogie components include rubber compounds out of natural rubber with different shore hardness and related synthetic rubber composites. The chemical resistance of these rubber compounds is chosen according to the mechanical requirements and therefore is comparable among each other.

### 8.6.2 Environmental impacts and loads

The rubber compounds used in bogies are resistant to environmental influences under normal climatic conditions which mean temperatures between -30 °C to +50 °C. Resistance against climatic influence, especially against ozone, and higher temperatures, caused e.g. by the waste heat of motors, is improved by the proportioning of appropriate chemicals.

## INFORMATION

- The elastomers used are resistant against loads which are usual in railway application.
- Pollutions caused by oil and lubricants as well as feces have to be removed regularly by using cleaning agents commonly used for bogies.
- Elastomers made of natural rubber are not permanently resistant against mineral oils and fuels.

### 8.6.3 Resistance against machine cleaning

The elastomers used are resistant against phosphoric acids and hydrochloric acids as well as against alkaline cleaning agents used for cleaning of the exterior of vehicles.

The resistance has been proven at selective elastomers made of natural rubber in test fluids according to DIN EN 13913:2003-08 representing other cleaning agents which are customary in trade.

Date	Document Number	Index	Page
2021-11-18	WH_41057501_Center Pivot Bearing_en	00	12   19

## INFORMATION

### Non pH-neutral cleaning agents

- Non pH-neutral cleaning agents damage the rubber.
- Use cleaning agents with a neutral pH-value. Do not use cleaning agents containing non-polar solvents (e.g. petrol). The components of the bogie have to be rinsed with water after the cleaning process otherwise the rubber-metal-bonding has to be protected against cleaning agents by constructive measures.

### 8.7 Cleaning

The components can be cleaned using detergents mentioned in Table 4. The specified concentrations as well as the specifications of manufacturer shall be observed obligatorily. The residues of the detergents shall be rinsed with clear water. The cleaned component has to be dried at room temperature.

## NOTICE



### Use of other differing cleaning agents

- The use of different detergents can damage the rubber.
- Only use detergents mentioned in Table 4.

Detergent	Concentration
Alkaline detergent	
Oxalic detergent	
Rapidol A	10 %
Rapidol W	10 %
Rapidol 58	10 %
Rapox	5 %
Rapox OS	5 %

Table 4: Detergents

## NOTICE



### Cleaning with sharp objects

- The use of sharp-edged objects (e.g. wire brushes, emery paper, etc.) is not permitted for cleaning elastomer products!

Date	Document Number	Index	Page
2021-11-18	WH_41057501_Center Pivot Bearing_en	00	13   19

Brief overview of resistance behavior or different elastomer compounds:														
	GROUP 1			GROUP 2						GROUP 3				
	NR			NBR	CR						EPDM			
acid resistance	B			B	A						A			
alkali resistance	B			B	A						A			
oil resistance	U			A	B						U			
Resistance to fuel	U			B	U						U			
Solvent resistance	U			B	B						B			
ozone resistance	B			B	A						A			
weatherability	B			A	A						A			
A = very good, little or no attack														
B = satisfactory, moderate to severe attack. Please contact the manufacturer!														
U = unsuitable for the application														

Table 5: resistance behavior of elastomers

### 8.8 Fire protection

Unless expressly required, elastomers made of natural rubber do not include any fire protection agents. The use of halogen-free fire protection agents causes a reduction in the mechanical properties; therefore, these protection agents are not used in components for dynamic load.

## 9 Decommissioning

- not applicable -

## 10 Disassembly

- not applicable -

For disassembly, the Center Pivot Bearing are pressed in the axial direction. It should be ensured that the force is applied only in the outer, metallic segments of the Center Pivot Bearing.

## 11 Disposal

Disposal / Product:

- Rubber-metal bonded materials with high rubber content may be disposed of in compliance with the local regulations of combustion (e.g. thermal recycling).
- Smaller quantities can be disposed of in compliance with the local regulations in the domestic waste dump.
- After dismantling, metallic components can be disposed of in the metal scrap recycling.

Waste code according to the European Waste List (Waste Catalogue Ordinance):

The AVV waste code numbers are not product-related but are largely source-related. The manufacturer is therefore unable to specify the waste code for articles or products used in various sectors. Waste codes can be requested from the manufacturer.

## **12 Error identification**

- not applicable -

## **13 Annex**

- Drawing GMT - No. 41057501

Date	Document Number	Index	Page
2021-11-18	WH_41057501_Center Pivot Bearing_en	00	15   19

8 7 6 5 4 3 2 1

F E D C B A

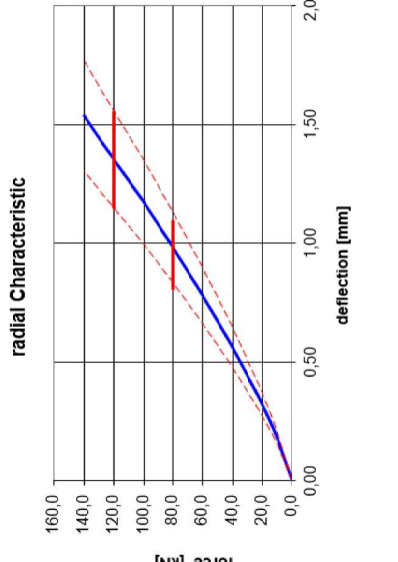

**TEST SPECIFICATIONS FOR SPRING DEFLECTION**

force direction: Radial  
 frequency of testing: 5%, min. 3 parts / batch  
 test control unit: ambient temperature  
 testing temperature: 100 N  
 initial loading: 2  
 number of settling cycles: 5 mm/min  
 settling speed: 140 KN  
 settling load up to: 5 mm/min  
 testing speed: 140 KN  
 testing measurement: S = 0,95 mm ±15% at F = 80 kN  
 1. deflection measurement: S = 1,35 mm ±15% at F = 120 kN  
 2. deflection measurement:  
 3. stiffness measurement:

**calculated stiffness:**

radial Cr = 80 kN/mm  
 axial Ca = 3.3 kN/mm  
 torsional Ct = 620 Nm/°

**XXX**  
 Markings in rubber (raised):  
 GMT logo  
 Date of manufacture  
 41057501  
 Cavity no.

Metals slightly oiled

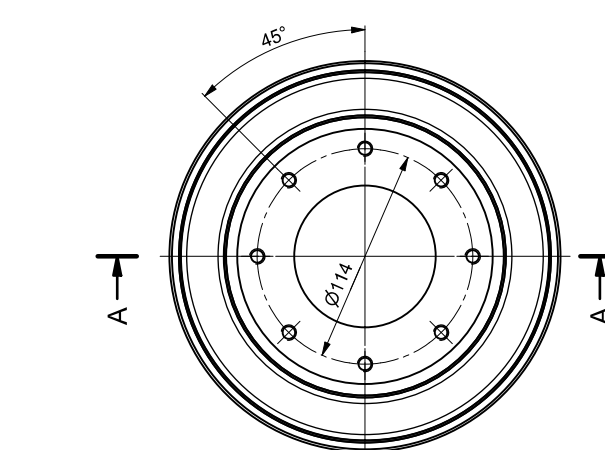
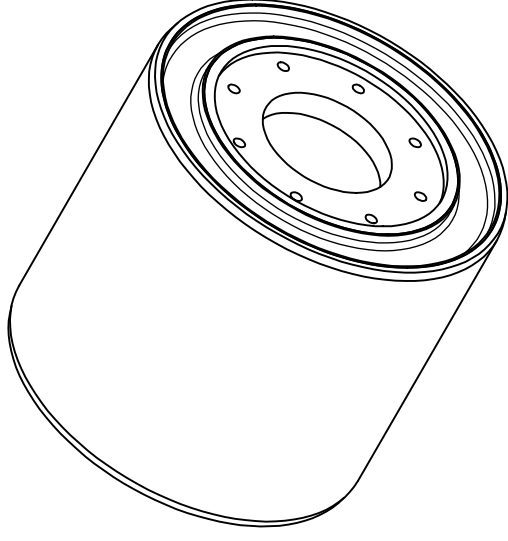
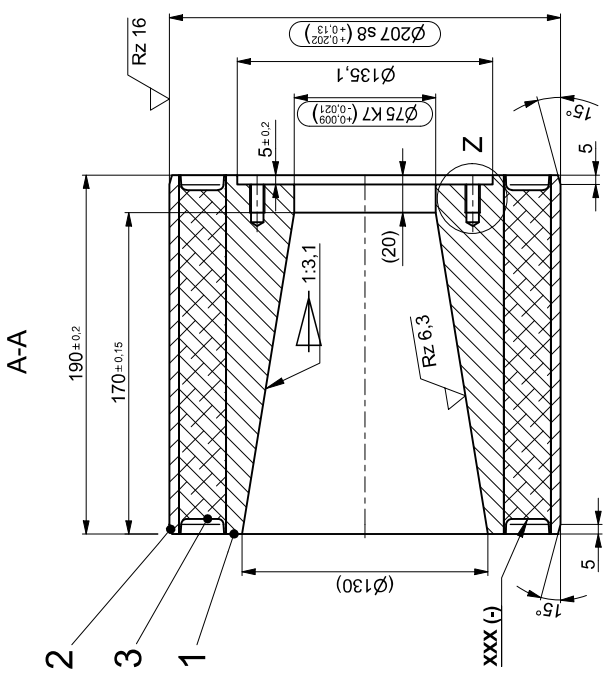
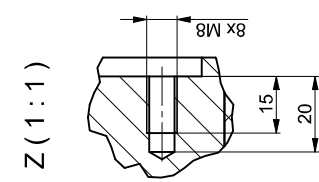

- 1) Basic requirements under clauses 1-6 in appendix to BN 918043 apply in all cases.
- 2) It is essential to indicate temperature range of application when outside room temperature.
- 3) Indicate here resistance to: e.g. accumulator acid and alkali, anti-freeze, propane, butane, urine, feces, other alkalis, corrosive action on other materials.
- 4) Contact with mineral based oil and grease must be avoided, short-time wetting during the assembly is permissible.

Impact resilience:	Class N I
Tear-growth resistance	Class N III
Tensile strength:	Class N I
Temperature range from: -30°C to +50°C	
Hardness:	Class M I / M II
Abrasion:	Class N I
Elongation at break:	Class N III
Compression set:	Class S II
Resistances to:	
Aging (at 70°C):	Class G
Oil:	Class G
Corrosion:	Class G
Heat:	Class N
Weather:	Class G

Resistance against mineral and fuel oil following DIN EN 13913 7.2.5 is not permanent.  
 Resistance against cleaning agents and feces following DIN EN 13913 7.2.6 is given.  
 Resistance against cleaning agents: in the pH range of 7±2.  
 Cleaner residues should be rinsed with clear water.

Allowable loads	
Nominal	100 kN
Exceptional	150 kN
Crash	380 kN
Radial	3°
Torsional	5°

Injection nepps, rubber coating and parting line burr allowable! Paint spray allowable on rubber! For components with surface coating the enlised dimensions are valid for the status before coating. Consequently, tolerances may be exceeded by the allowable coat thickness.

GAD Zeichnung - Darf manuell nicht geändert werden!  
 CAD drawing - Must not be changed manually!

MeiStab / Scale: 1 : 2  
 Gewicht / Weight: 20.3 kg

Material: Elastomer OPI 1352  
 Materials acc. to parts list

Benennung / Description:  
**Drenzapfenlager**  
 Center pivot bearing

Zeichnungsnr. / Drawing no.: 41057501  
 Index: 000

Modell: 41057501

Position	Modification	Date	Name
1			

All dimensions in mm

Established	Drawn	Checked	Approved
02/20/21	02/20/21	02/20/21	02/20/21

GMT  
 GOMT GmbH  
 02763 Berlin, Germany

## 14 Subject Index

- not applicable -

Date	Document Number	Index	Page
2021-11-18	WH_41057501_Center Pivot Bearing_en	00	17   19

## 15 Index

<b>GMT</b>	<b>Center Pivot Bearing</b>	<b>41057501</b>
Manufacturer	Article	Drawing Number
<b>WH_41057501_Center Pivot Bearing_en</b>		
Document		
<b>2021-11-17</b>	<b>00</b>	<b>C. Palm</b>
Document Created (Date)	Index	Document Created (Name)

### State of Revision

Document Modification										
Mod.	Index (Record Modified Chapters Here)									
	01	02	03	04	05	06	07	08	09	10
1										
2										
3										
4										
5										
6										
7										
8										
9										
10										
11										
12										

### Index

Index	Date	Reason of Modification	Responsibility
00	2021-11-17	First Issue	C. Palm

<b>Prepared</b>	Date	2021-11-17	GMT Engineering	Christian Palm
<b>Released</b>	Date	2021-11-18	GMT Engineering	Stefan Schemel

Date	Document Number	Index	Page
2021-11-18	WH_41057501_Center Pivot Bearing_en	00	18   19



Gummi · Metall · Technik

**Copyright 2021 GMT Gummi-Metall-Technik GmbH**

**Maintenance instruction Center Pivot Bearing GMT - No. 41057501 Rev. 00**

The contents of this publication must not be modified in any manner in whole or in part, nor reproduced in any form or forwarded to third parties without prior written consent of GMT.

The creation of this documentation was carried out with due diligence so that GMT assume no liability for any remaining errors or omissions as well as for any possible resulting damages. All trademarks or registered trademarks are the property of their respective owners.

All rights reserved.

**Contact:**

GMT Gummi-Metall-Technik GmbH

Liechtersmatten 5

D-77815 Bühl

<http://www.gmt-gmbh.de>

Date	Document Number	Index	Page
2021-11-18	WH_41057501_Center Pivot Bearing_en	00	19   19